

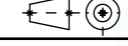

ANG.PROJ.: 				گروه صنایع سیمان کرمان	
TELORANCE: ISO 2768-1 (Tolerance Class m) ISO 2768-2 (Tolerance Class k) ISO 13920 (Tolerance Class A)				(سهامی عام)	
UNIT: mm, kg				TITLE: Bag filter main body	
Document Type: Assem	DRAWN	M.H.Izadi	SIGNATURE	DATE	PART NO.: BF-01-01-00
QTY.: ***	CHECKED	M.S.Arabnejad			Document ID: **
Revision:	APPROVED	A.Anjomshoa			REF. Document ID:
Revision Date:	Material: --				Record ID:
Classification:	WEIGHT: 1547.0 Kg			Scale: 1:50	Sheet: 3 of 61
					Size: A3



ITEM NO.	PART NUMBER	PART NAME	WEIGHT(KG)	MATERIAL	QTY.
1	BF-01-01-01	Bag filter main body part 01	1025.7	--	1
2	BF-01-01-02	Bag filter walk way Part.01	110.8	--	1
3	BF-01-01-03	Bag filter walk way Part.02	121.3	--	1
4	BF-01-01-04	Bag filter walk way Part.03	106.9	--	1
5	BF-01-01-05	Bag filter hand rail part.01	12.4	--	2
6	BF-01-01-06	Bag filter ladder Part.01	20.3	--	1
7	BF-01-01-07	Bag filter ladder structure part.01	30.6	--	2
8	BF-01-01-08	Bag filter ladder safety cage Part.01	34.1	--	1
9	BF-01-01-09	Bag filter main body UPN80.01	11.8	ST37	2
10	BF-01-01-10	Bag filter main body plate.01	10.0	ST37	2
11	BF-01-01-11	Bag filter hand rail part.05	10.1	--	1
12	BF-01-01-12	Bag filter safety Plate.01 (1945x150x2)	4.6	ST37	2
13	BF-01-01-13	Bag filter safety Plate.02 (1363x150x2)	3.2	ST37	2
14	BF-01-01-14	Bag filter safety Plate.03 (1353x150x2)	3.2	ST37	1

ANG.PROJ.:

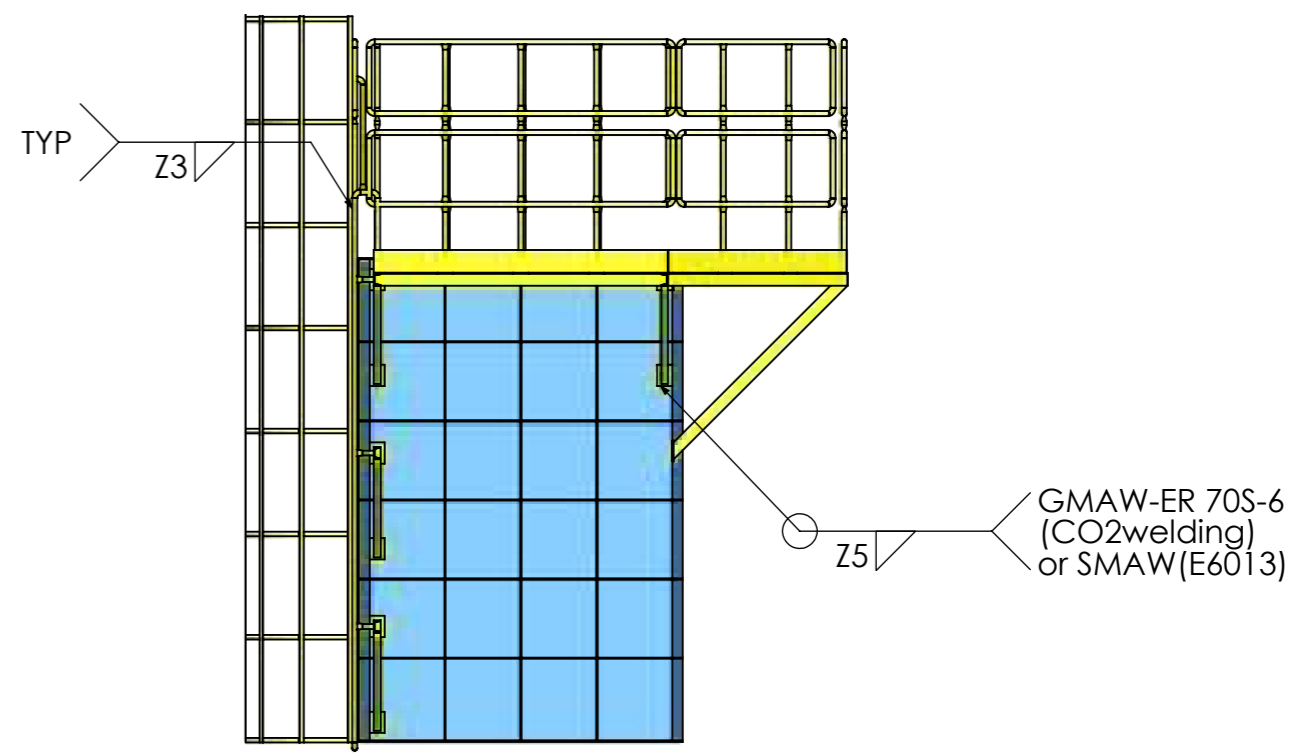
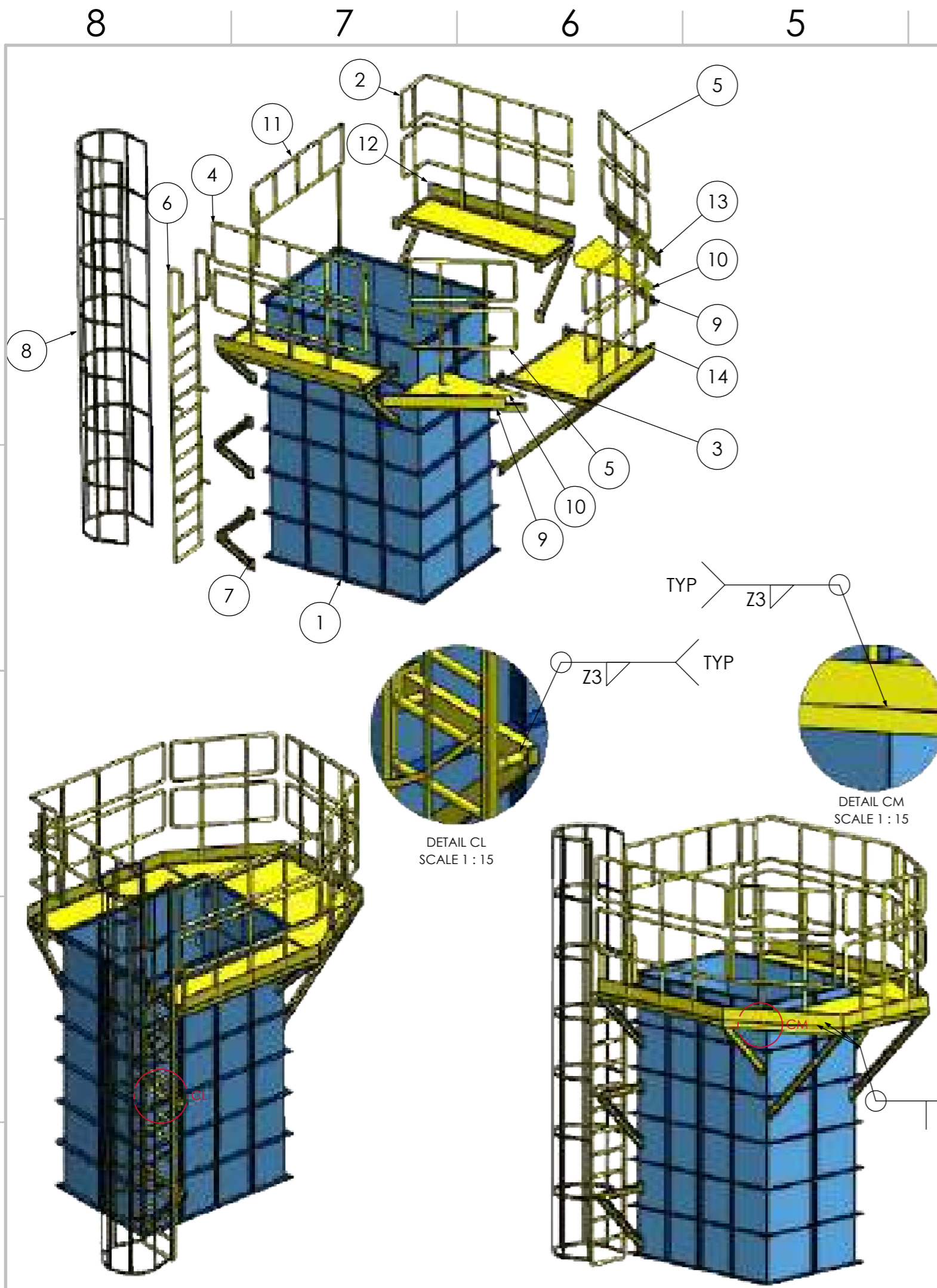
TELERANCE: ISO 2768-1 (Tolerance Class m) ISO 2768-2 (Tolerance Class k) ISO 13920 (Tolerance Class A)

UNIT: mm, kg

Document Type: **Assem**

QTY.: ***

Revision:

Revision Date:

Classification:

WEIGHT: 1547.0 Kg

Scale: 1:100

Sheet: 4 of 61

Size: A3

گروه صنایع سیمان کرمان (سهامی عام)

Bag filter main body

PART NO.: BF-01-01-00

Document ID: **

REF. Document ID:

Record ID:

NAME	SIGNATURE	DATE	TITLE
DRAWN	M.H.Izadi		
CHECKED	M.S.Arabnejad		
APPROVED	A.Anjomshoa		

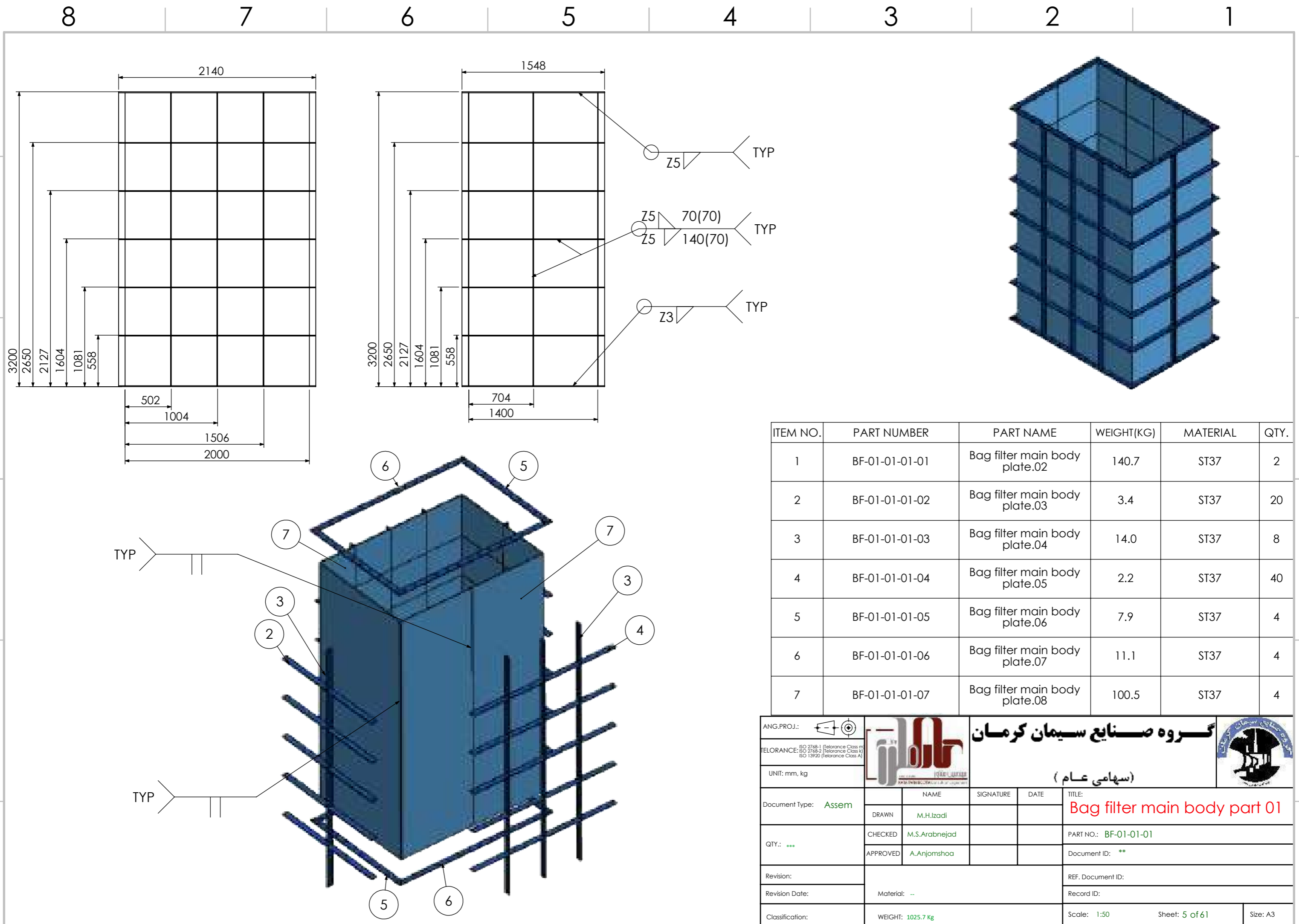

ITEM NO.	PART NUMBER	PART NAME	WEIGHT(KG)	MATERIAL	QTY.
1	BF-01-01-01-01	Bag filter main body plate.02	140.7	ST37	2
2	BF-01-01-01-02	Bag filter main body plate.03	3.4	ST37	20
3	BF-01-01-01-03	Bag filter main body plate.04	14.0	ST37	8
4	BF-01-01-01-04	Bag filter main body plate.05	2.2	ST37	40
5	BF-01-01-01-05	Bag filter main body plate.06	7.9	ST37	4
6	BF-01-01-01-06	Bag filter main body plate.07	11.1	ST37	4
7	BF-01-01-01-07	Bag filter main body plate.08	100.5	ST37	4

ANG.PROJ.:				
TELORANCE:	ISO 2768-1 (Tolerance Class m) ISO 2768-2 (Tolerance Class k) ISO 13920 (Tolerance Class A)			
UNIT: mm, kg	گروه صنایع سیمان کرمان (سهامی عام)			
Document Type: Assem	NAME	SIGNATURE	DATE	TITLE: Bag filter main body part 01
QTY.: ***	DRAWN: M.H.Izadi	CHECKED: M.S.Arabnejad	APPROVED: A.Anjomshoa	PART NO.: BF-01-01-01
Revision:	Material: --			REF. Document ID:
Revision Date:	WEIGHT: 1025.7 Kg			Record ID:
Classification:	Scale: 1:50		Sheet: 5 of 61	Size: A3

8 7 6 5 4 3 2 1

F

F

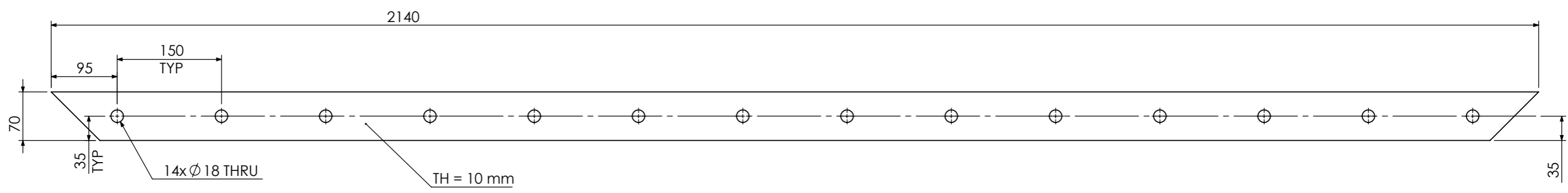

Bag filter main body plate.07
BF-01-01-01-06

D

D

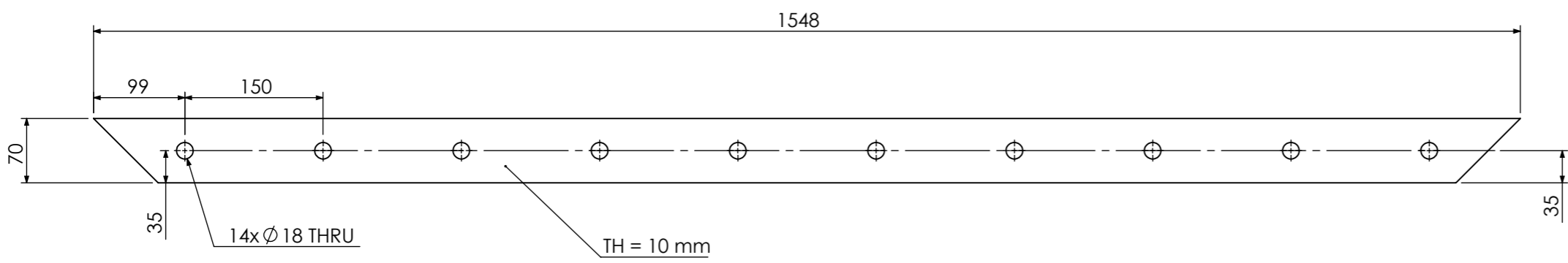

Bag filter main body plate.06
BF-01-01-01-05

C

C

B

B

ANG.PROJ.:			گروه صنایع سیمان کرمان		
TELORANCE: ISO 2768-1 (Tolerance Class m) ISO 2768-2 (Tolerance Class k) ISO 13920 (Tolerance Class A)			(سهامی عام)		
UNIT: mm, kg					
Document Type: Part		NAME	SIGNATURE	DATE	TITLE: Bag filter main body plate(6-7)
	DRAWN	M.H.Izadi			
	CHECKED	M.S.Arabnejad			PART NO.: BF-01-01-01-(05-06)
QTY.: ***	APPROVED	A.Anjomshoa			Document ID: **
Revision:					REF. Document ID:
Revision Date:	Material: --				Record ID:
Classification:	WEIGHT: 11.1 Kg		Scale: 1:20		Sheet: 6 of 61
					Size: A3

A

A

8 7 6 5 4 3 2 1

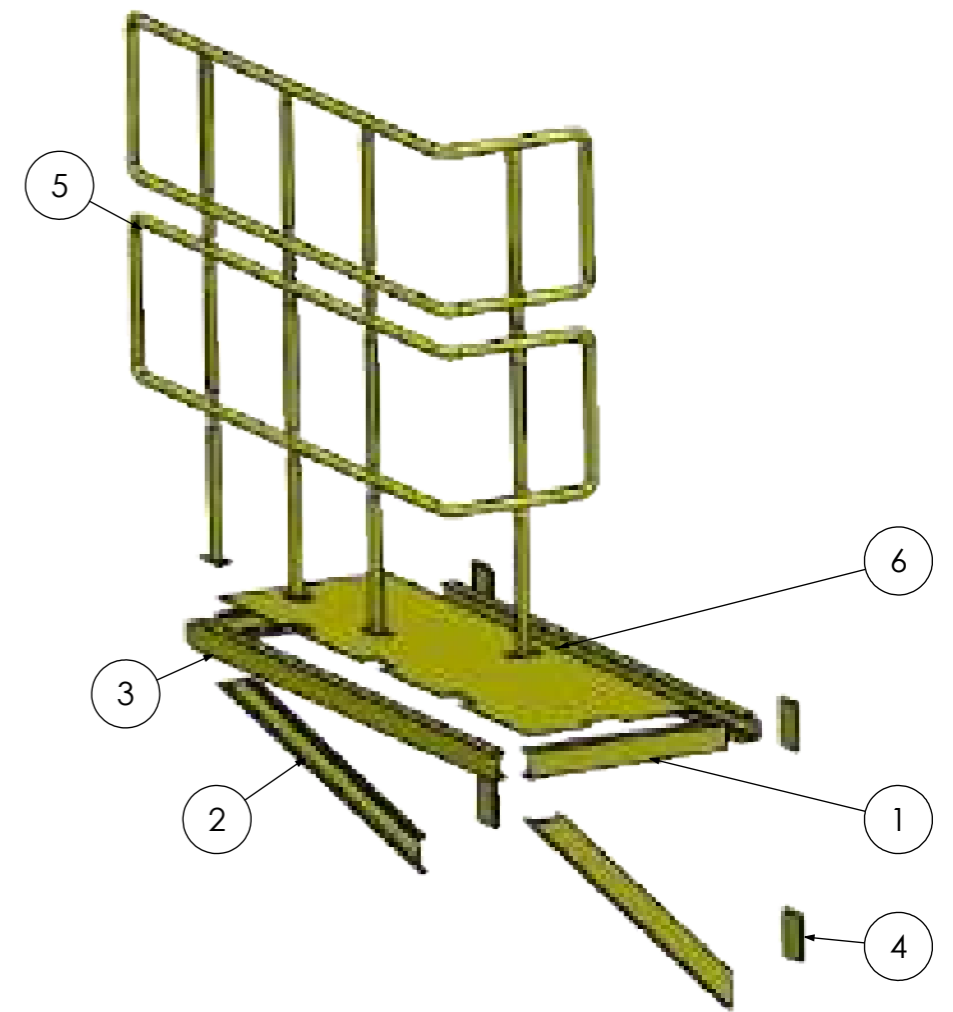
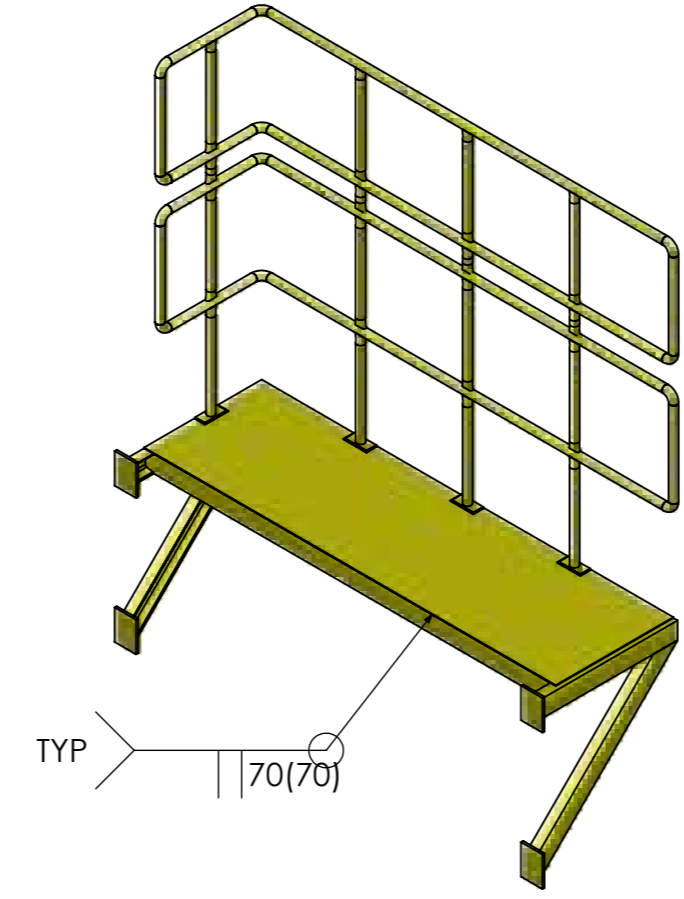
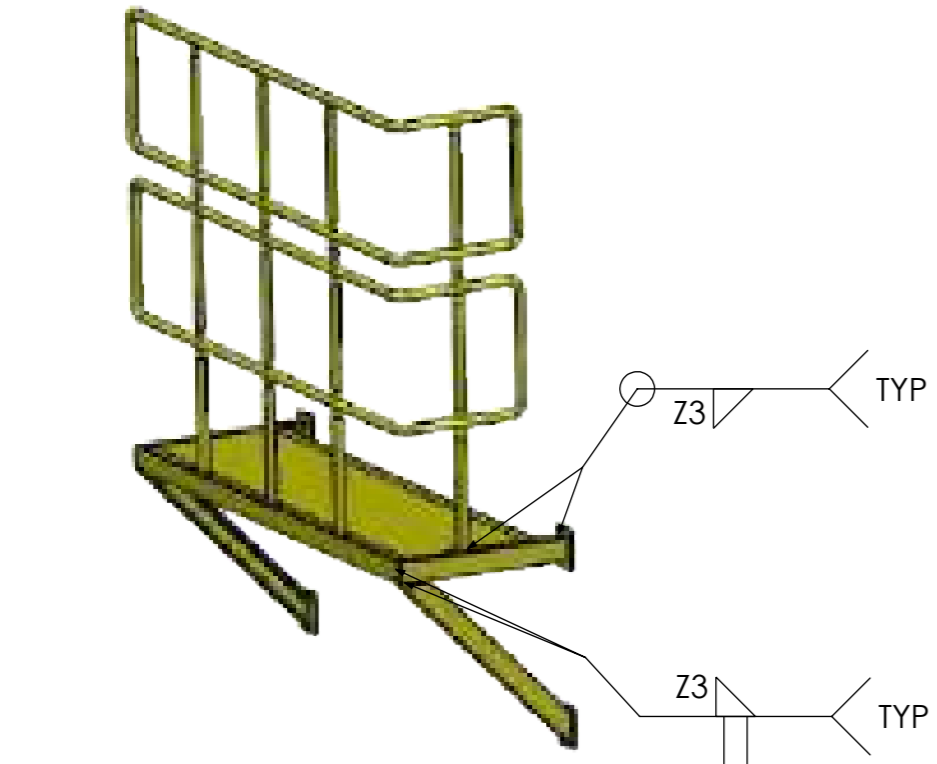
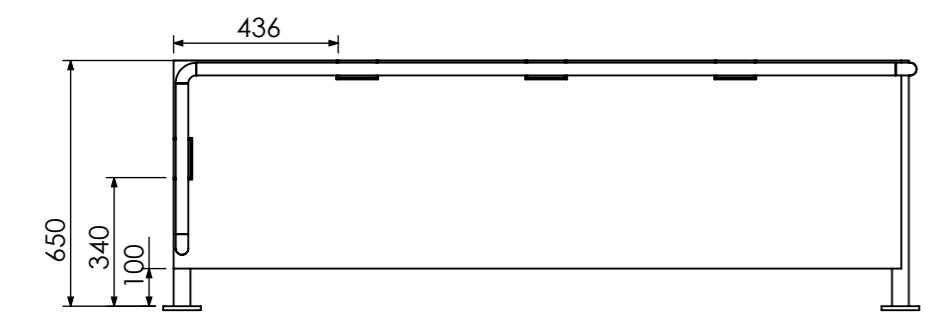
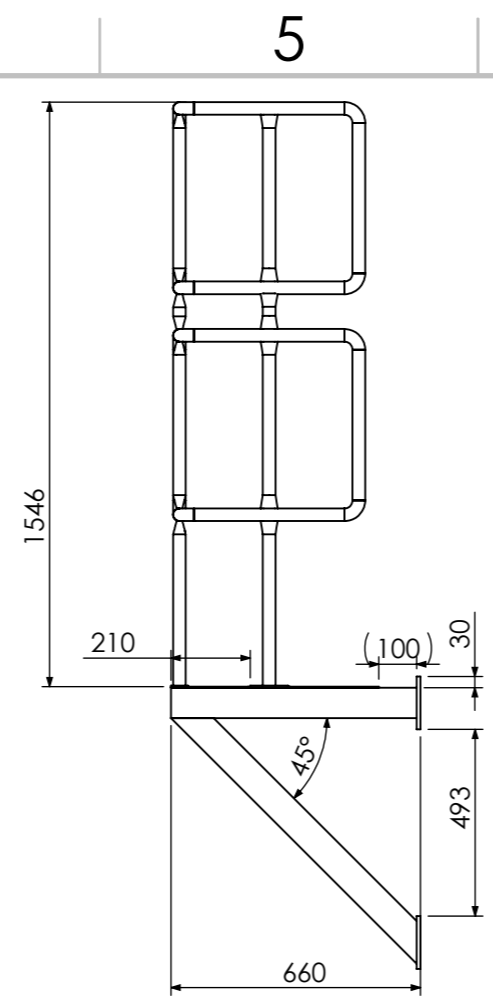
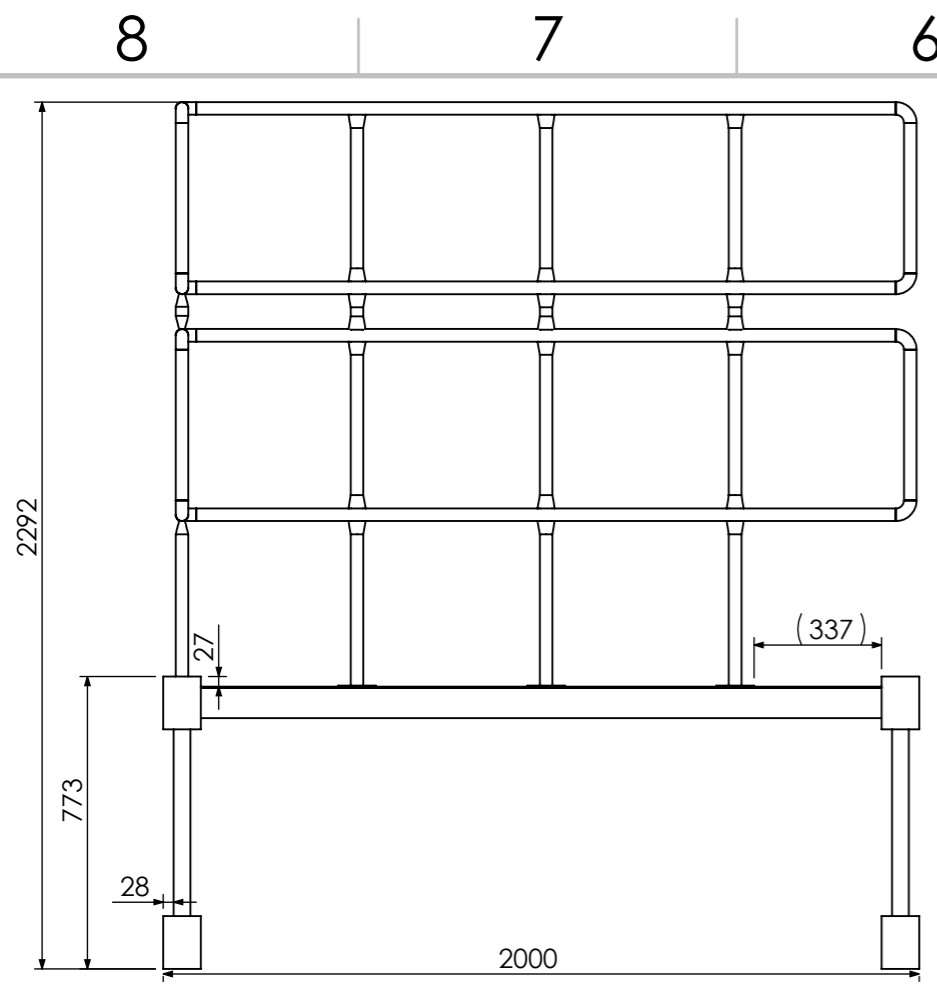

ITEM NO.	PART NUMBER	PART NAME	WEIGHT(KG)	MATERIAL	QTY.
1	BF-01-01-02-01	Bag filter walk way UPN80.01 (L=650 simple)	5.7	ST37	2
2	BF-01-01-02-02	Bag filter walk way UPN80.02	7.4	ST37	2
3	BF-01-01-02-03	Bag filter walk way UPN80.03	16.6	ST37	2
4	BF-01-01-02-04	Bag filter walk way Plate.01 (100mm x 140 mm x 10 mm)	1.1	ST37	4
5	BF-01-01-02-05	Bag filter hand rail part.02	22.7	--	1
6	BF-01-01-02-06	Bag filter walk way Plate.02	24.4	ST37	1

ANG.PROJ.:

TELORANCE: ISO 2768-1 (Tolerance Class m)
ISO 2768-2 (Tolerance Class k)
ISO 13920 (Tolerance Class A)

UNIT: mm, kg

Document Type: **Assem**

QTY.: ***

Revision:

Revision Date:

Classification:

گروه صنایع سیمان کرمان
(سهامی عام)

NAME: M.H.Izadi
SIGNATURE:
DATE:
TITLE: **Bag filter walk way Part.01**

CHECKED: M.S.Arabnejad
APPROVED: A.Anjomshoa
PART NO.: BF-01-01-02
Document ID: **

Material: --

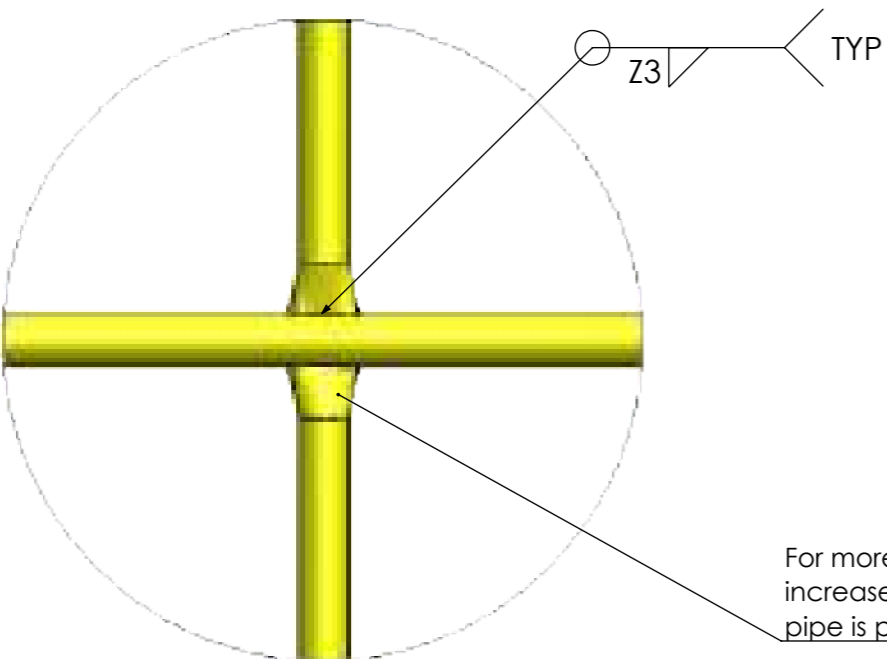
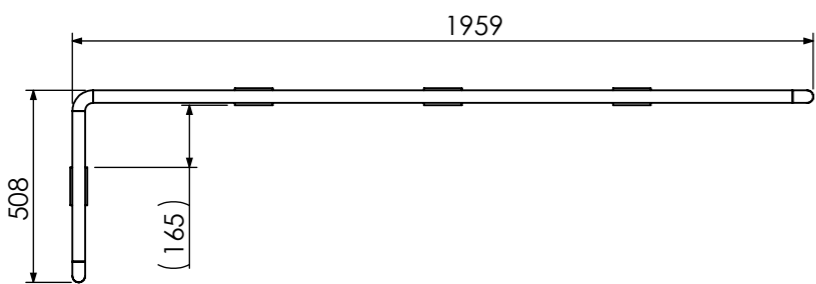
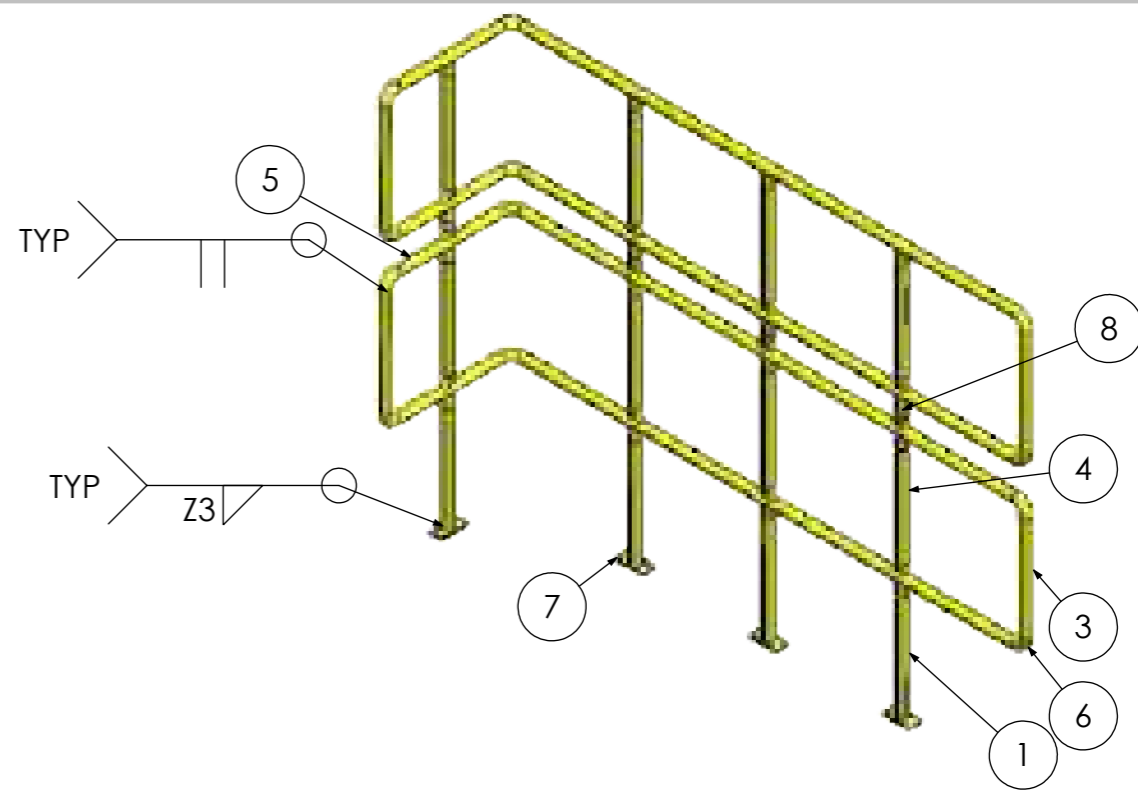
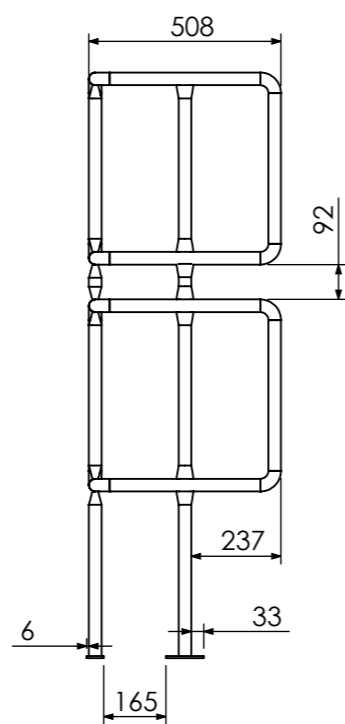
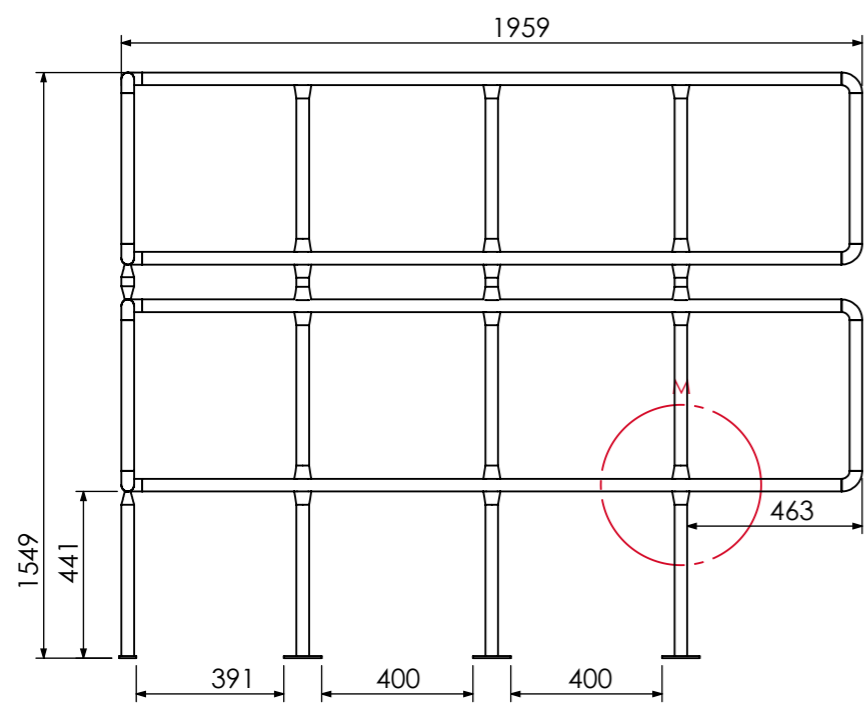

WEIGHT: 110.8 Kg

REF. Document ID:
Record ID:
Scale: 1:20
Sheet: 7 of 61
Size: A3



DETAIL M
SCALE 1 : 5

ITEM NO.	PART NUMBER	PART NAME	WEIGHT(KG)	MATERIAL	QTY.
1	BF-01-01-02-05-01	pipe-ANSI B36.19-1inx 1.65mmL:600mm-welded Pipe	0.6	ST37	4
2	BF-01-01-02-05-02	pipe-ANSI B36.19-1inx 1.65mmL:1850mm-welded Pipe	2.4	ST37	4
3	BF-01-01-02-05-03	pipe-ANSI B36.19-1inx 1.65mmL:398.4mm-welded Pipe	0.5	ST37	4
4	BF-01-01-02-05-04	pipe-ANSI B36.19-1inx 1.65mmL:441mm-welded Pipe	0.6	ST37	8
5	BF-01-01-02-05-05	pipe-ANSI B36.19-1inx 1.65mmL:398.4mm-welded Pipe	0.5	ST37	4
6	BF-01-01-02-05-06	1 in welded elbow (90 degree)	0.1	ST37	12
7	BF-01-01-02-05-07	Bag filter hand rail plate.01 (100mm x 45 mm x 6 mm)	0.2	ST37	4
8	BF-01-01-02-05-04	pipe-ANSI B36.19-1inx 1.65mmL:94mm-welded Pipe	0.1	ST37	4

ANG.PROJ.:				
TELORANCE: ISO 2768-1 (Tolerance Class m) ISO 2768-2 (Tolerance Class k) ISO 13920 (Tolerance Class A)	 گروه صنایع سیمان کرمان (سهامی عام)			
UNIT: mm, kg				
Document Type: Assem	NAME	SIGNATURE	DATE	TITLE: Bag filter hand rail part.02
QTY.: ***	DRAWN: M.H.Izadi	CHECKED: M.S.Arabnejad	APPROVED: A.Anjomshoa	PART NO.: BF-01-01-02-05
Revision:	Material: --			REF. Document ID:
Revision Date:	WEIGHT: 22.7 Kg			Record ID:
Classification:	Scale: 1:20		Sheet: 8 of 61	Size: A3

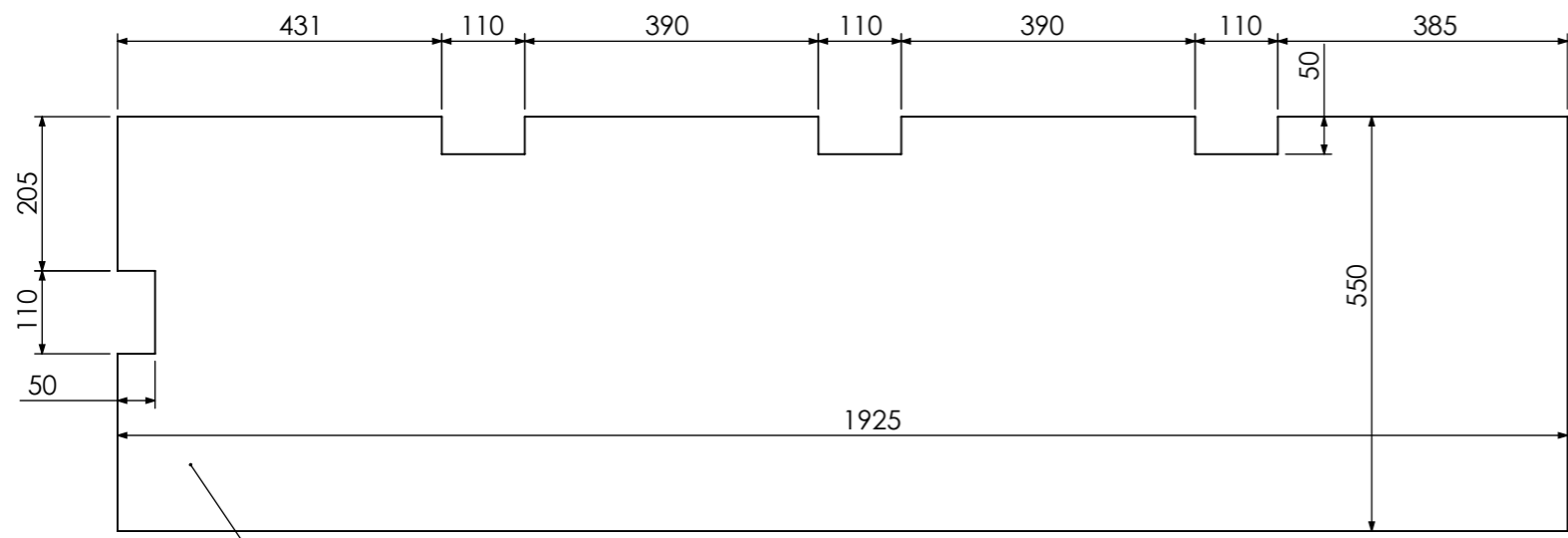

TH = 10 mm

Bag filter walk way Plate.02
BF-01-01-02-06

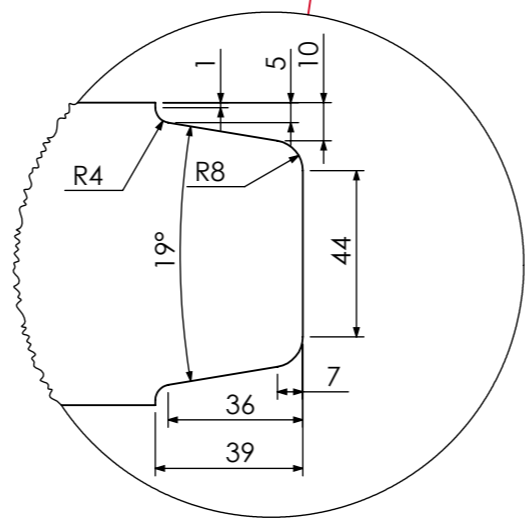
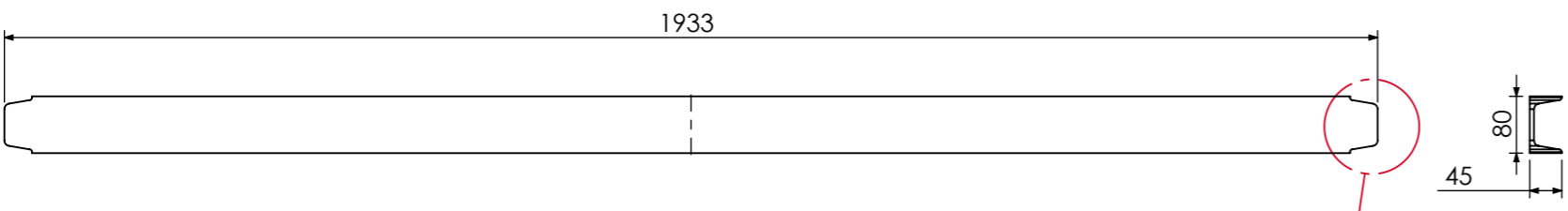
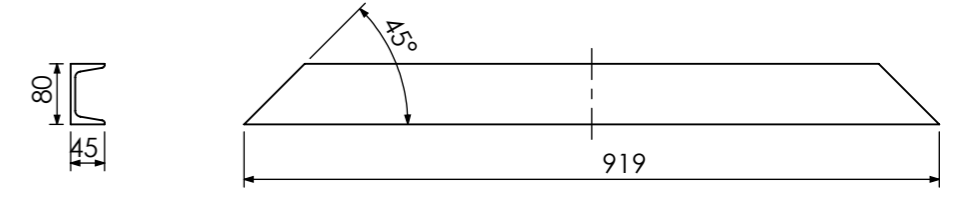

Bag filter walk way UPN80.03
BF-01-01-02-03

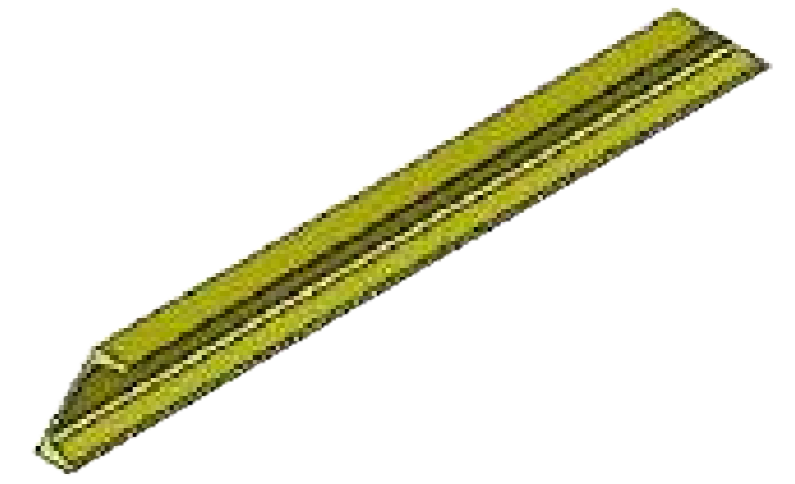

Bag filter walk way UPN80.02
BF-01-01-02-02

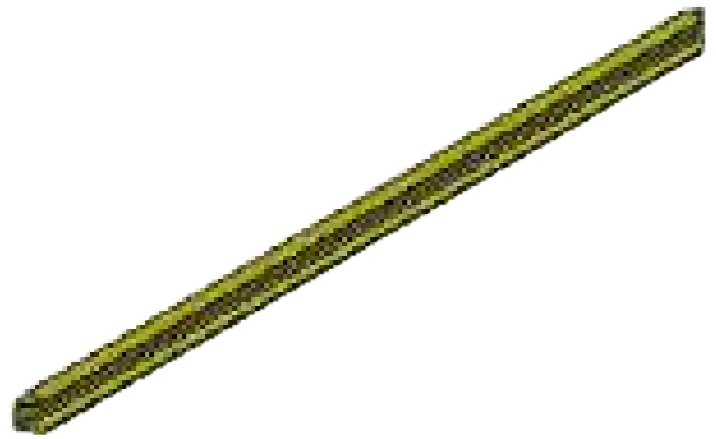

ANG.PROJ.:	 گروه صنایع سیمان کرمان 			
TELORANCE:	<small>ISO 2768-1 (Tolerance Class m) ISO 2768-2 (Tolerance Class k) ISO 13920 (Tolerance Class A)</small>			
UNIT: mm, kg	(سهامی عام)			
Document Type: Part	NAME	SIGNATURE	DATE	TITLE: Bag filter walk way Plate.02 Bag filter walk way UPN80(02-03)
QTY.: **	DRAWN: M.H.Izadi	CHECKED: M.S.Arabnejad	APPROVED: A.Anjomshoa	PART NO.: BF-01-01-02-(02-03-06)
Revision:	Material: --			Document ID: **
Revision Date:	WEIGHT: 16.6 Kg			REF. Document ID:
Classification:	Scale: 1:20			Record ID:
	Sheet: 9 of 61			Size: A3

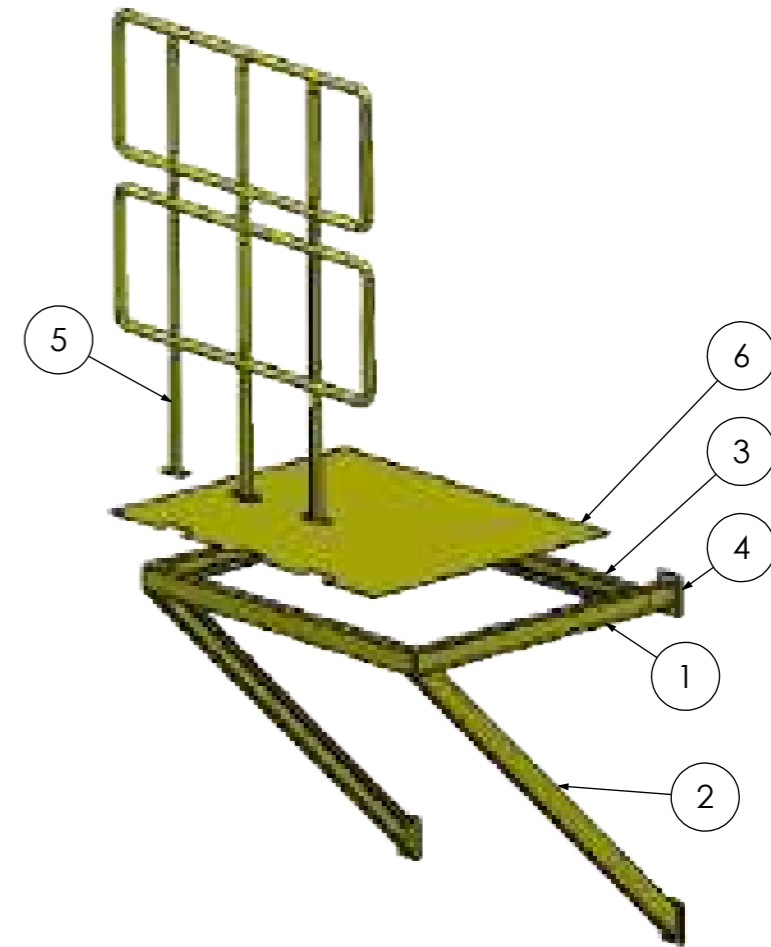
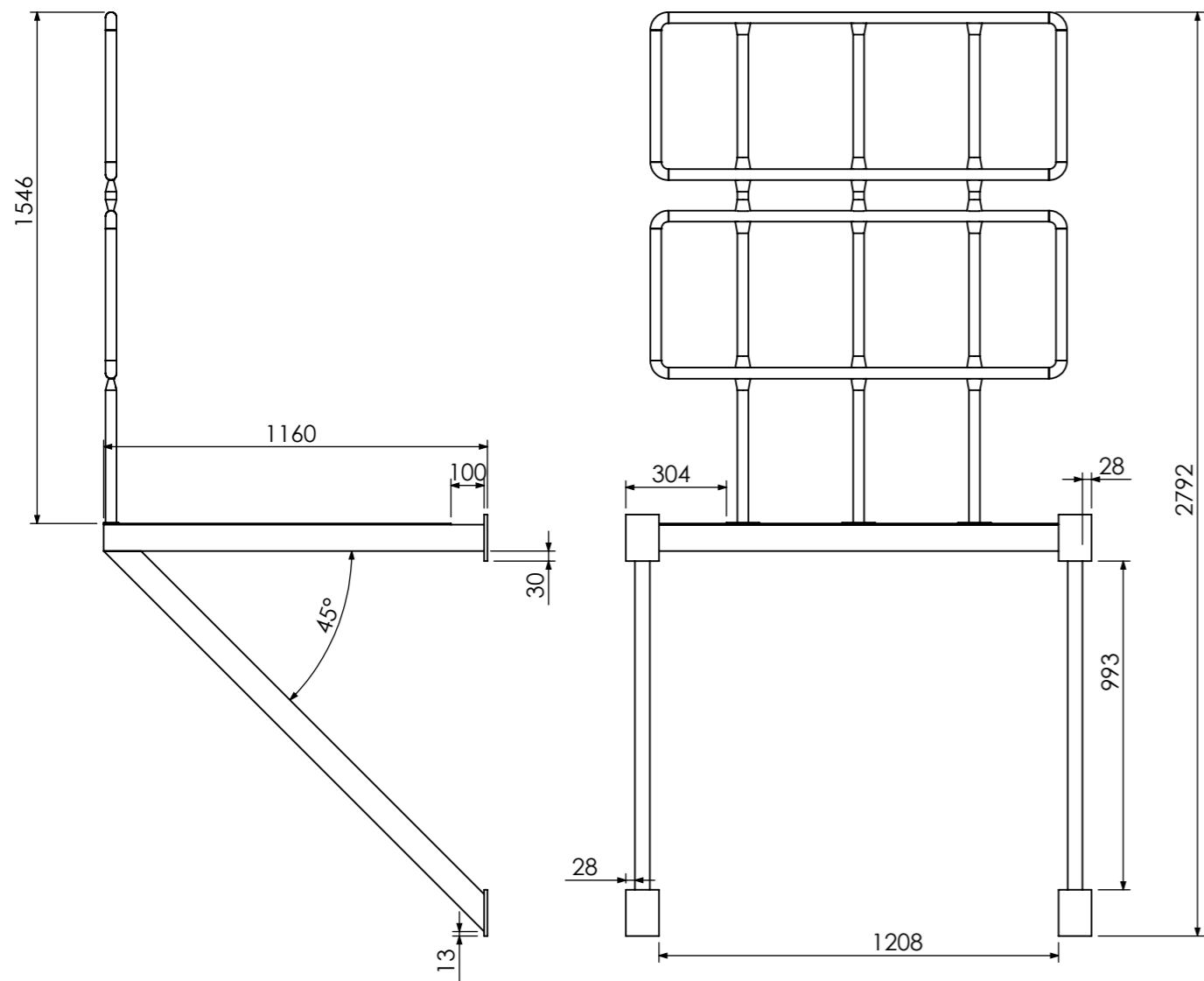

ITEM NO.	PART NUMBER	PART NAME	WEIGHT(KG)	MATERIAL	QTY.
1	BF-01-01-03-01	Bag filter walk way UPN80.04 (L=1150 simple)	10.1	ST37	2
2	BF-01-01-03-02	Bag filter walk way UPN80.05	13.6	ST37	2
3	BF-01-01-03-03	Bag filter walk way UPN80.06	11.4	ST37	2
4	BF-01-01-02-04	Bag filter walk way Plate.01 (100mm x 140 mm x 10 mm)	1.1	ST37	4
5	BF-01-01-03-04	Bag filter hand rail part.03	14.7	ST37	1
6	BF-01-01-03-05	Bag filter walk way Plate.03	32.1	ST37	1

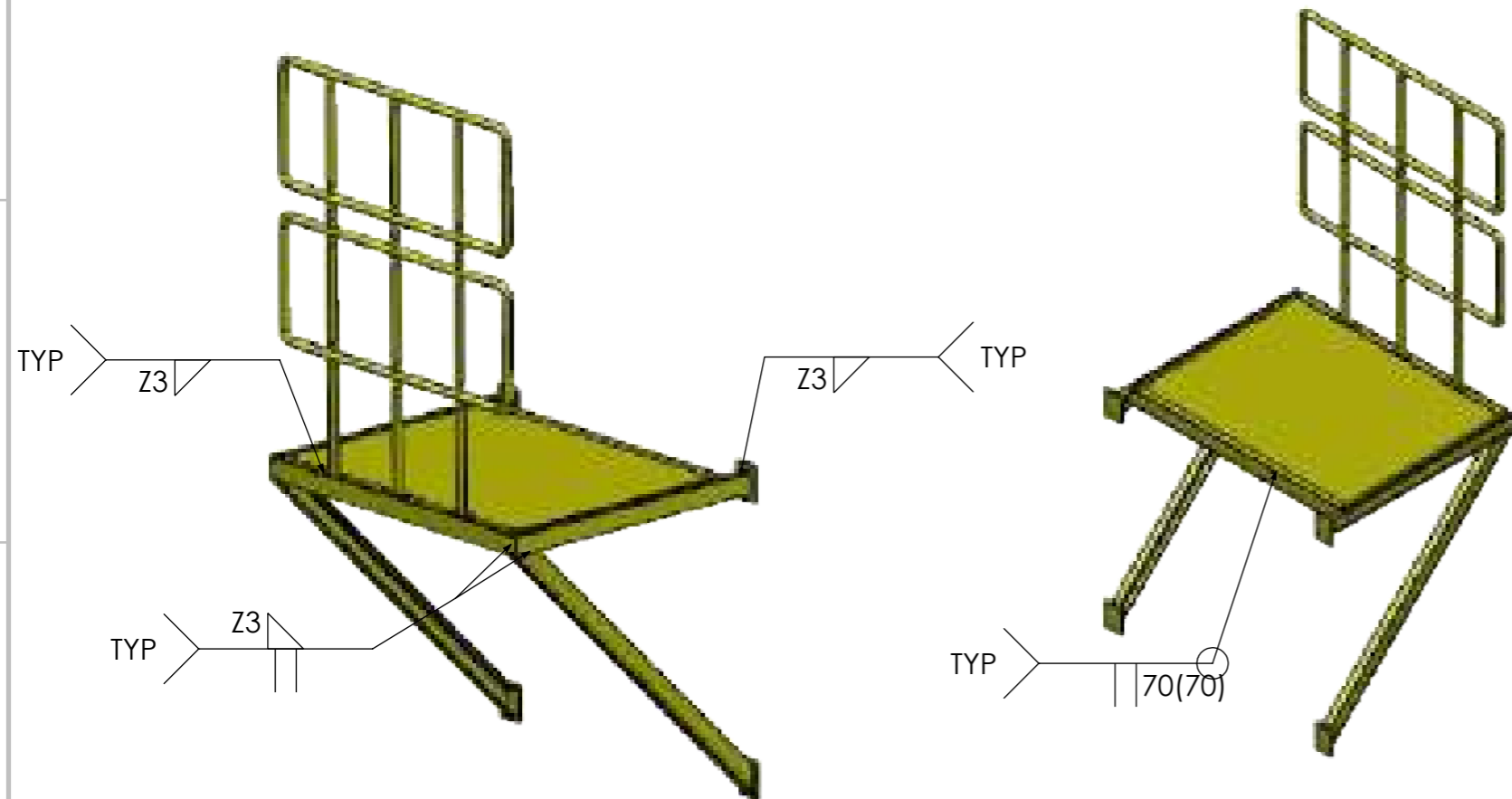

ANG.PROJ.:	 گروه صنایع سیمان کرمان (سهامی عام)				
TELORANCE: ISO 2768-1 (Tolerance Class m) ISO 2768-2 (Tolerance Class k) ISO 13920 (Tolerance Class A)	کارخانه Kerman Industrial University of Technology				
UNIT: mm, kg					
Document Type: Assem	NAME	SIGNATURE	DATE	TITLE: Bag filter walk way Part.02	
QTY.: ***	DRAWN: M.H.Izadi			PART NO.: BF-01-01-03	
	CHECKED: M.S.Arabnejad			Document ID: **	
	APPROVED: A.Anjomshoa				
Revision:				REF. Document ID:	
Revision Date:	Material: --			Record ID:	
Classification:	WEIGHT: 121.3 Kg	Scale: 1:50		Sheet: 10 of 61	Size: A3

8 7 6 5 4 3 2 1

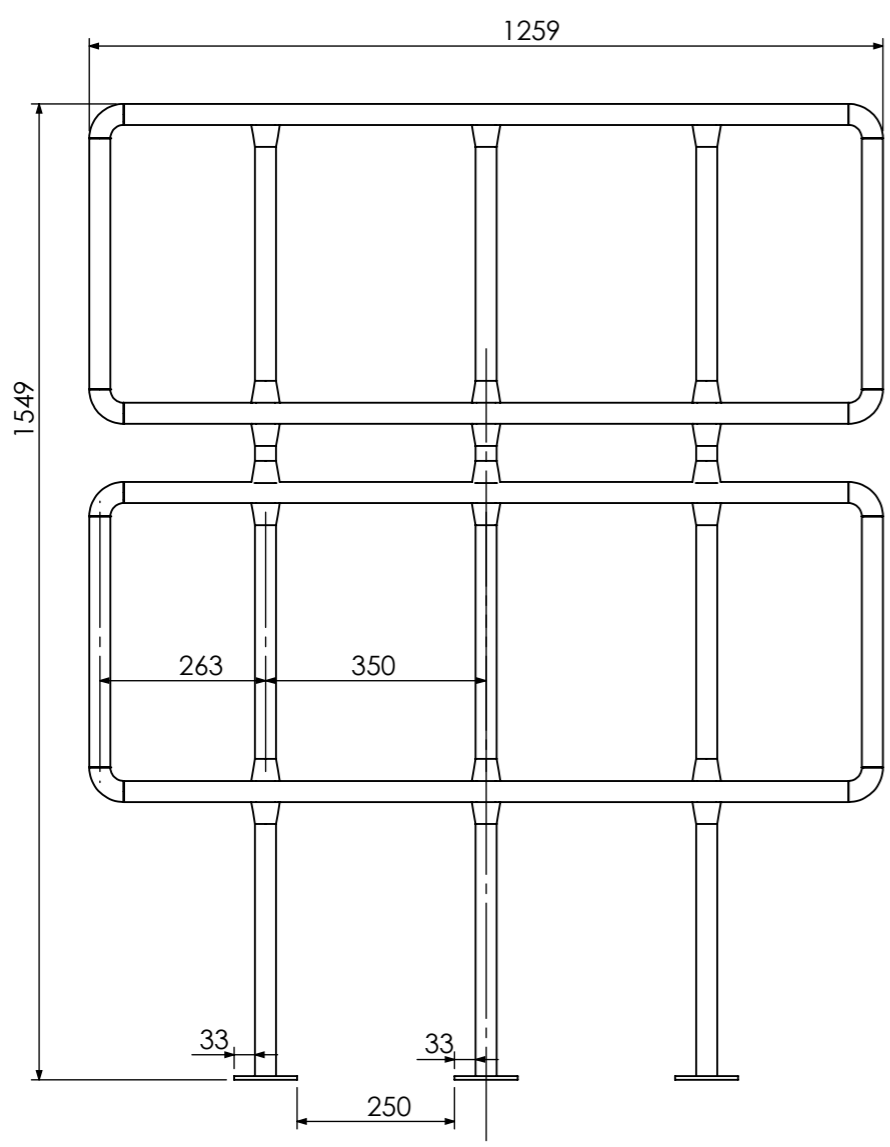

SCALE 1 : 12

For more reliable welding and increased durability, the end of the pipe is pressed to the size of 2 cm.

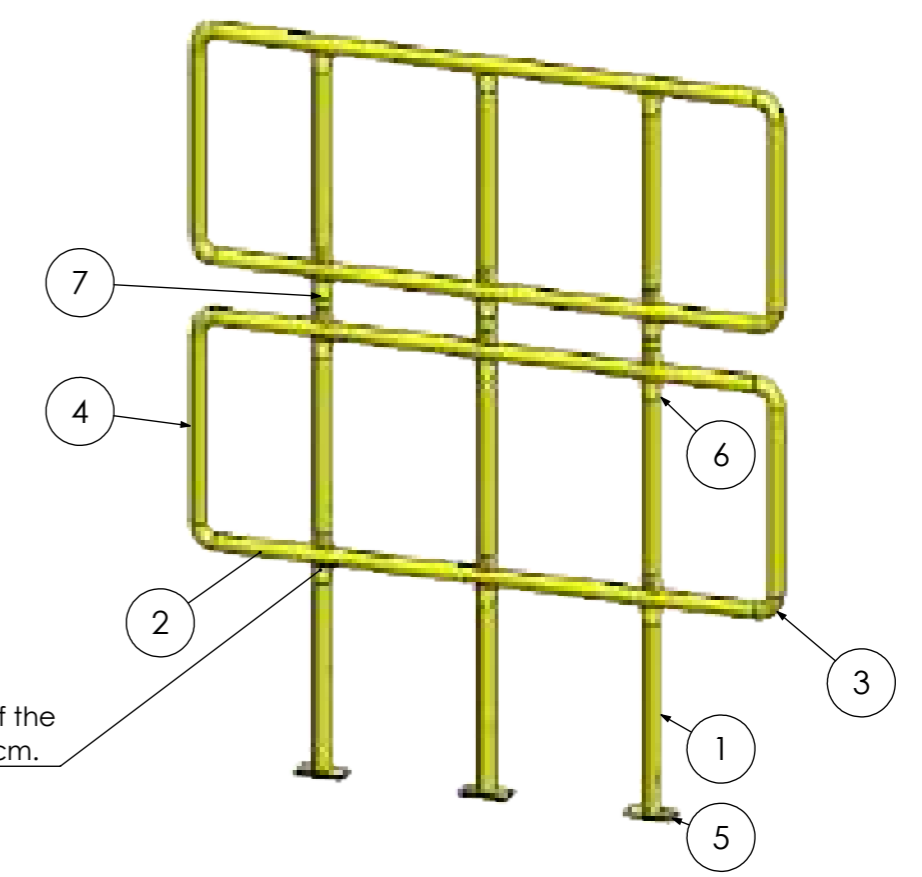

ITEM NO.	PART NUMBER	PART NAME	WEIGHT(KG)	MATERIAL	QTY.
1	BF-01-01-02-05-01	pipe-ANSI B36.19-1inx 1.65mmL:600mm-welded Pipe	0.6	ST37	3
2	BF-01-01-03-05-01	pipe-ANSI B36.19-1inx 1.65mmL:1150mm-welded Pipe	1.5	ST37	4
3	BF-01-01-02-05-06	1 in welded elbow (90 degree)	0.1	ST37	8
4	BF-01-01-02-05-03	pipe-ANSI B36.19-1inx 1.65mmL:398.4mm-welded Pipe	0.5	ST37	4
5	BF-01-01-02-05-07	Bag filter hand rail plate.01 (100mm x 45 mm x 6 mm)	0.2	ST37	3
6	BF-01-01-02-05-04	pipe-ANSI B36.19-1inx 1.65mmL:441mm-welded Pipe	0.6	ST37	6
7	BF-01-01-02-05-04	pipe-ANSI B36.19-1inx 1.65mmL:94mm-welded Pipe	0.1	ST37	3

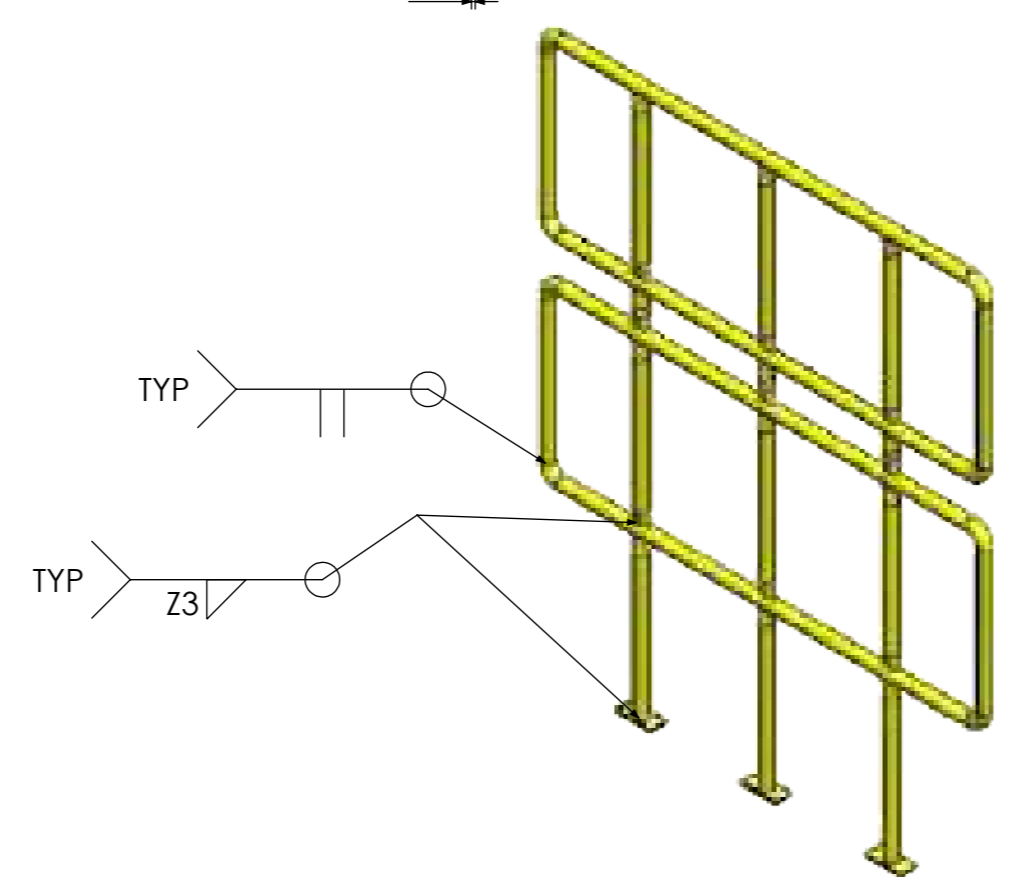

ANG.PROJ.:

TELORANCE: ISO 2768-1 (Tolerance Class m) ISO 2768-2 (Tolerance Class k) ISO 13920 (Tolerance Class A)

UNIT: mm, kg

Document Type: **Assem**

QTY.: ***

Revision:
 Revision Date:
 Classification:

NAME: M.H.Izadi
 SIGNATURE:
 DATE:
 TITLE: **Bag filter hand rail part.03**

PART NO.: BF-01-01-03-04
 Document ID: **
 REF. Document ID:
 Record ID:

WEIGHT: 14.7 Kg
 Scale: 1:10
 Sheet: 11 of 61
 Size: A3

8 7 6 5 4 3 2 1

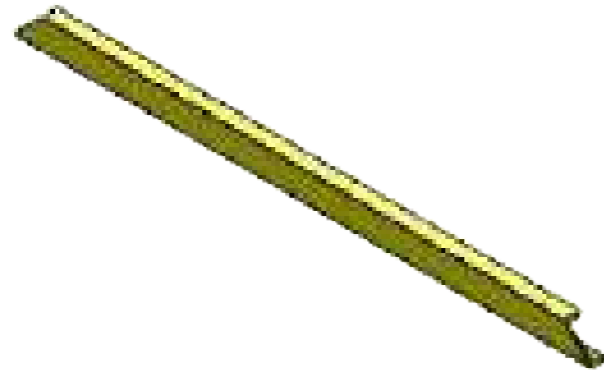
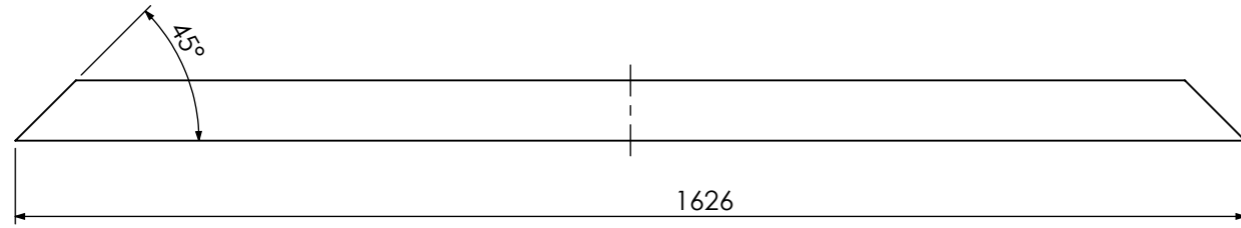
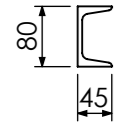

Bag filter walk way UPN80.05
BF-01-01-03-02

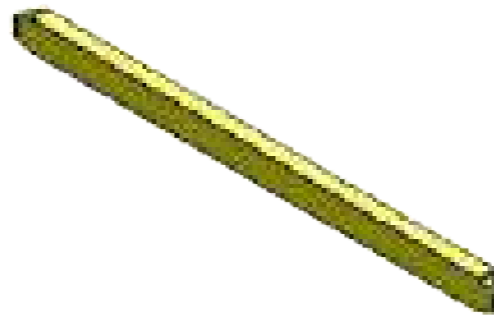
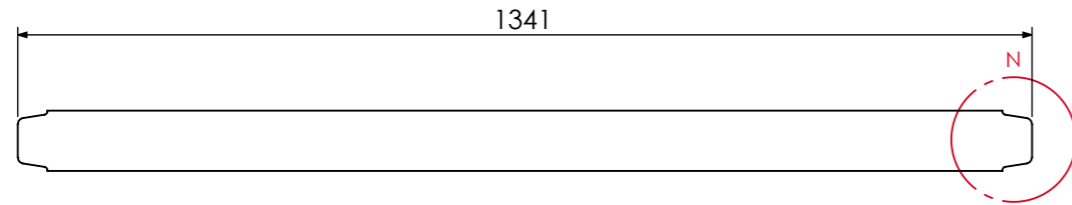
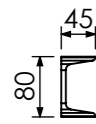

Bag filter walk way UPN80.06
BF-01-01-03-03

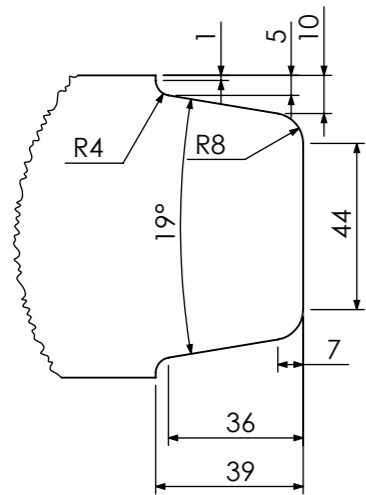

DETAIL N
SCALE 1 : 1

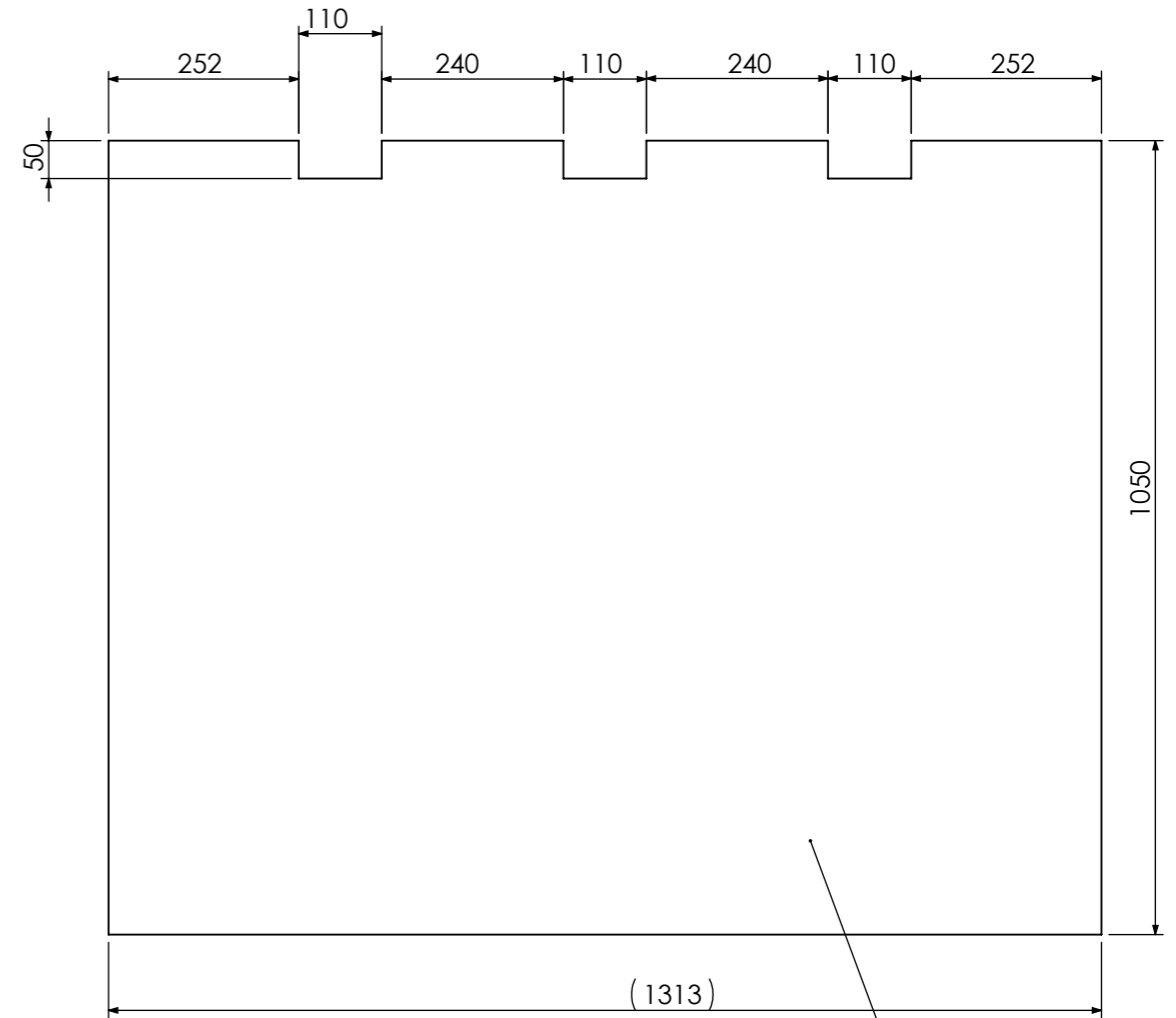

TH = 3 mm

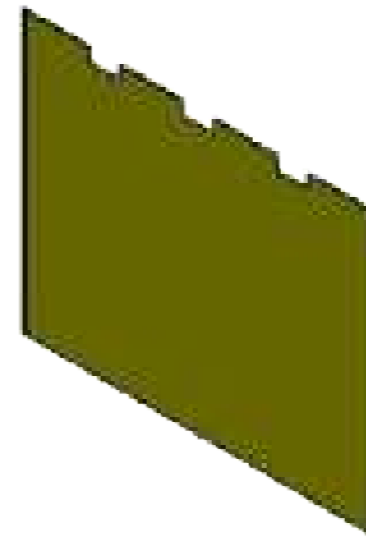

Bag filter walk way Plate.03
BF-01-01-03-05

ANG.PROJ.:	گروه صنایع سیمان کرمان (سهامی عام)			
TOLERANCE: ISO 2768-1 (Tolerance Class m) ISO 2768-2 (Tolerance Class k) ISO 13920 (Tolerance Class A)				
UNIT: mm, kg				
Document Type: Part	NAME	SIGNATURE	DATE	TITLE: Bag filter walk way Plate.03 Bag filter walk way UPN80(05-06)
QTY.: ***	DRAWN	M.H.Izadi		PART NO.: BF-01-01-03-(02-03-05)
	CHECKED	M.S.Arabnejad		
Revision:	APPROVED			A.Anjomshoa
Revision Date:	Material: --			REF. Document ID:
Classification:	WEIGHT: 13.6 Kg			Record ID:
			Scale: 1:20	Sheet: 12 of 61
			Size: A3	

8 7 6 5 4 3 2 1

F
E
D
C
B
A

F
E
D
C
B
A

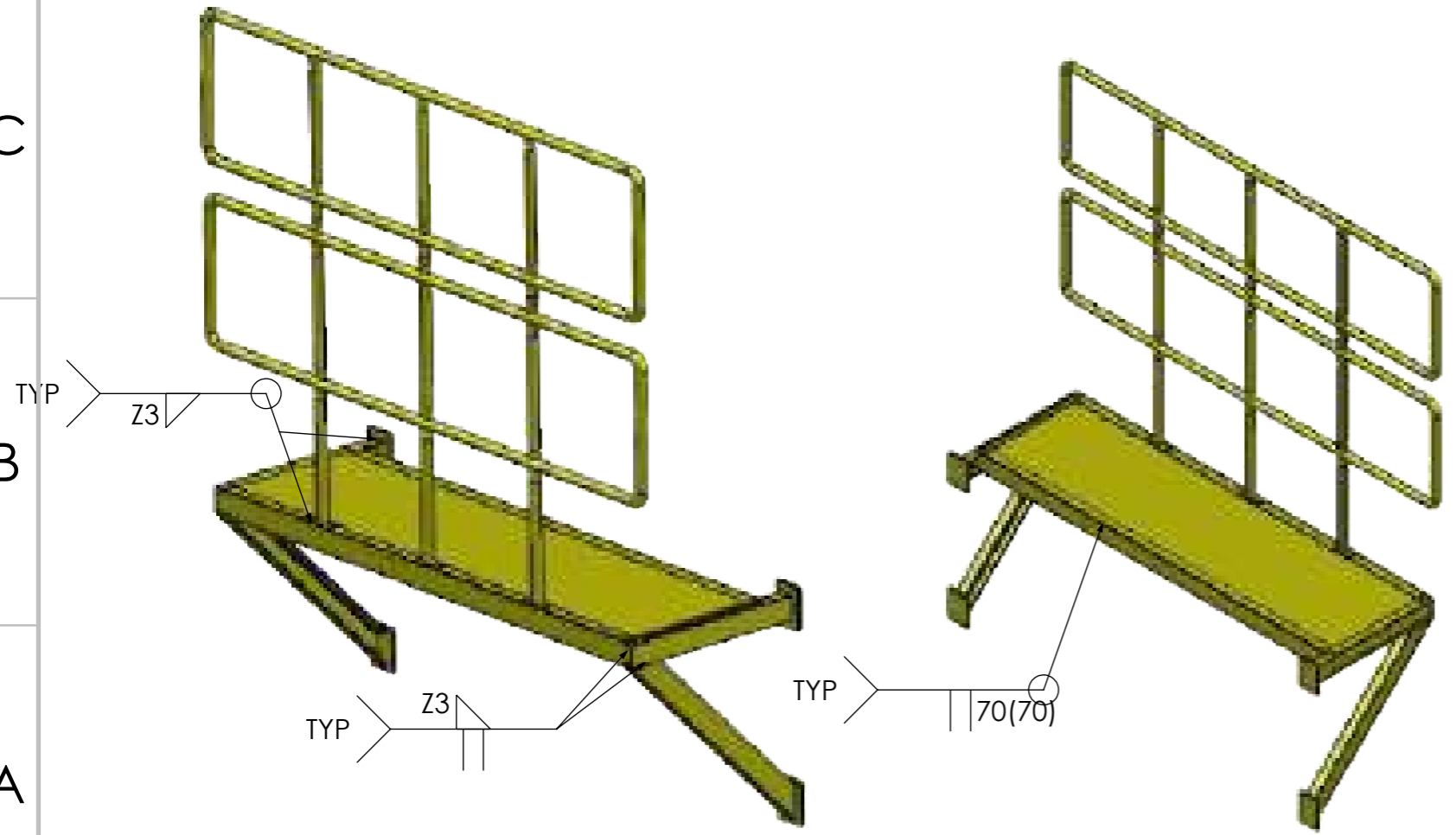
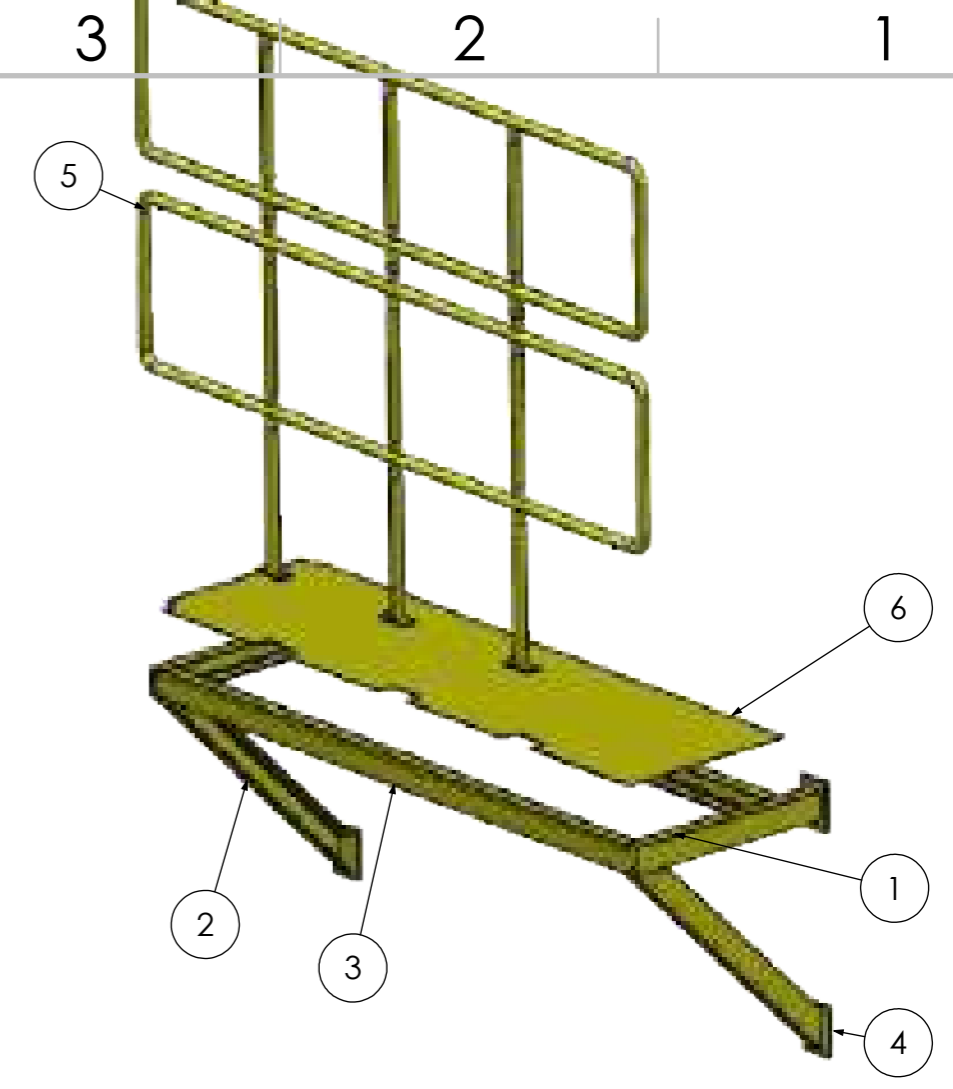
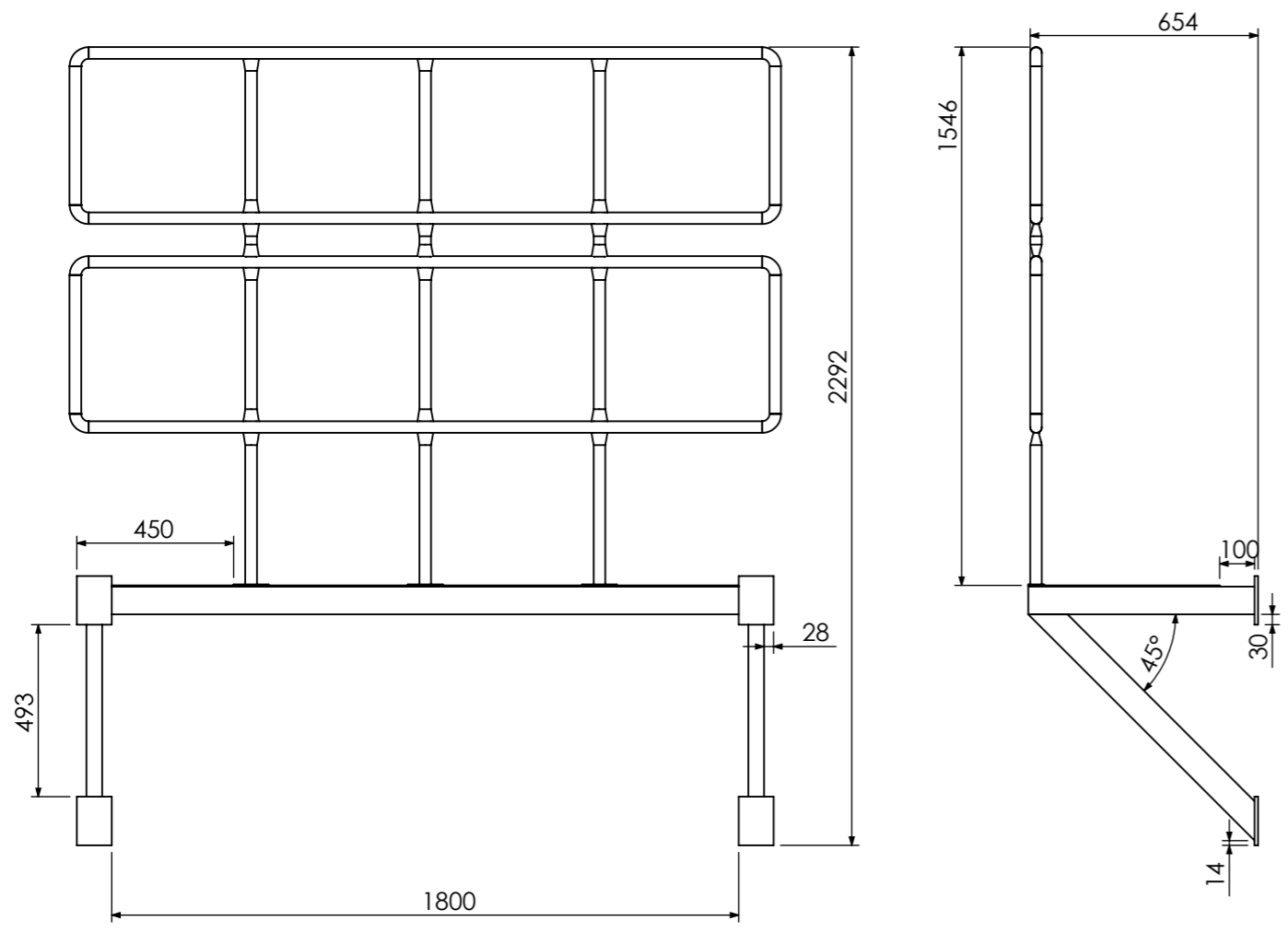

ITEM NO.	PART NUMBER	PART NAME	WEIGHT(KG)	MATERIAL	QTY.
1	BF-01-01-02-01	Bag filter walk way UPN80.01 (L=650 simple)	5.7	ST37	2
2	BF-01-01-02-02	Bag filter walk way UPN80.02	7.4	ST37	2
3	BF-01-01-04-01	Bag filter walk way UPN80.07	16.6	ST37	2
4	BF-01-01-02-04	Bag filter walk way Plate.01 (100mm x 140 mm x 10 mm)	1.1	ST37	4
5	BF-01-01-04-02	Bag filter hand rail part.04	18.8	--	1
6	BF-01-01-04-03	Bag filter walk way Plate.04	24.5	ST37	1

ANG.PROJ.:	گروه صنایع سیمان کرمان (سهامی عام)			
TELORANCE: ISO 2768-1 (Tolerance Class m) ISO 2768-2 (Tolerance Class k) ISO 13920 (Tolerance Class A)				
UNIT: mm, kg	NAME	SIGNATURE	DATE	TITLE:
Document Type: Assem	DRAWN: M.H.Izadi			Bag filter walk way Part.03
QTY.: ***	CHECKED: M.S.Arabnejad			PART NO.: BF-01-01-04
	APPROVED: A.Anjomshoa			Document ID: **
Revision:				REF. Document ID:
Revision Date:	Material: --			Record ID:
Classification:	WEIGHT: 106.9 Kg	Scale: 1:20	Sheet: 13 of 61	Size: A3

8 7 6 5 4 3 2 1

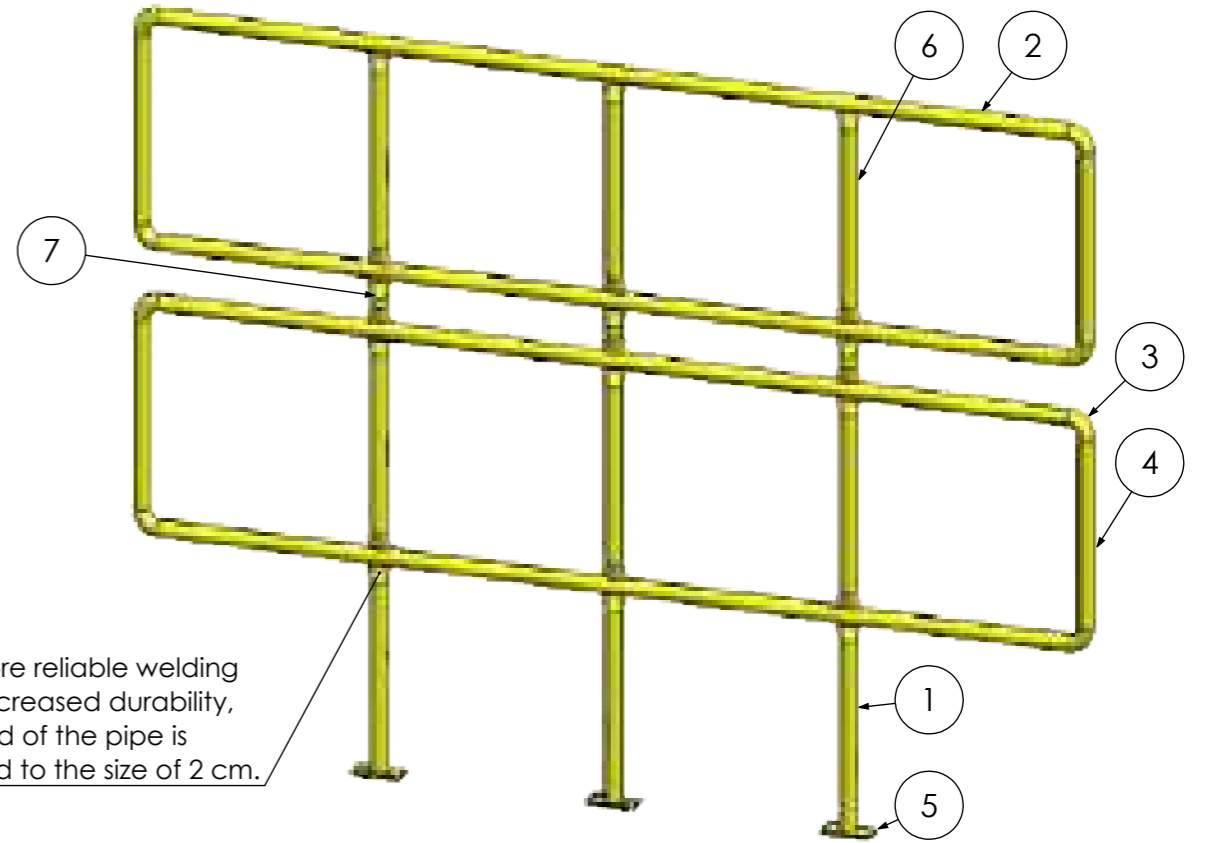
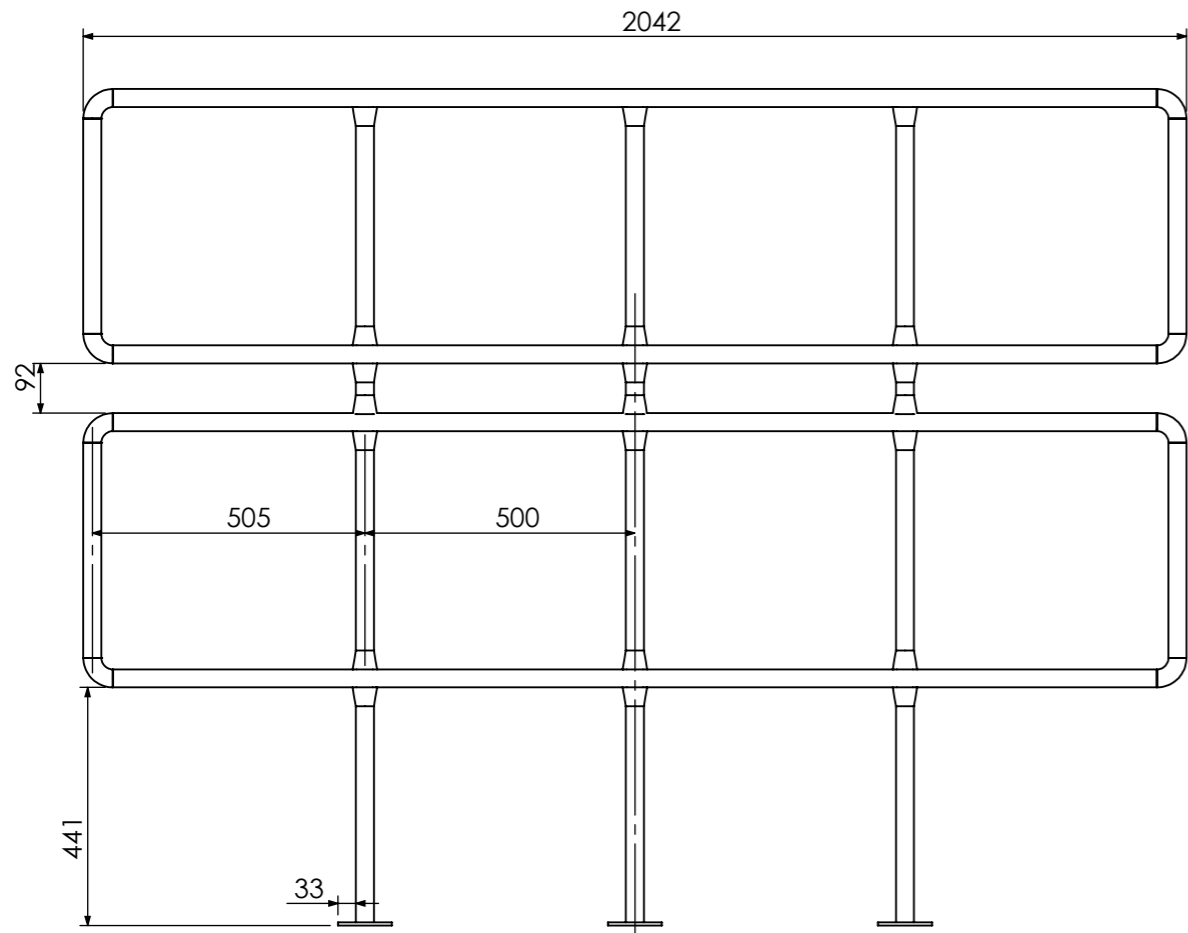

For more reliable welding and increased durability, the end of the pipe is pressed to the size of 2 cm.

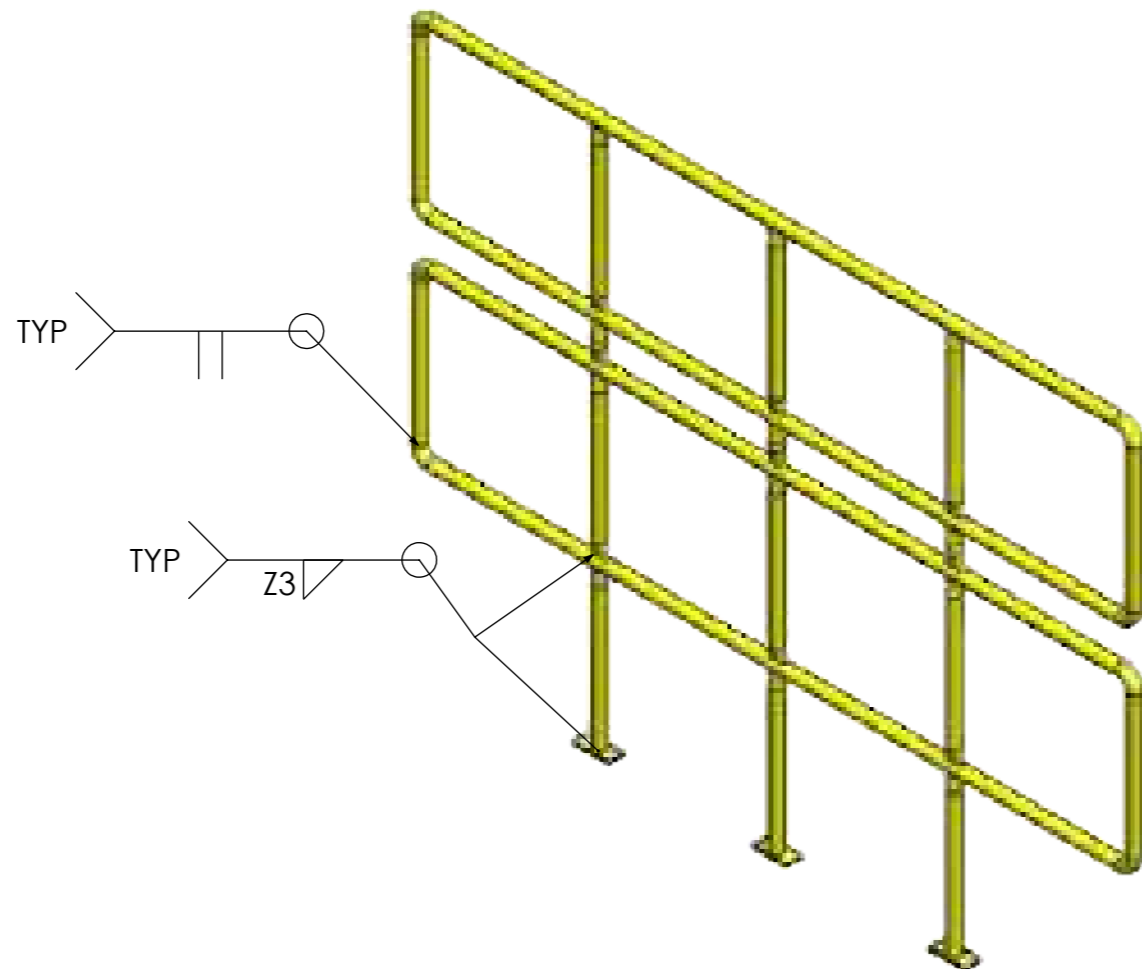

ITEM NO.	PART NUMBER	PART NAME	WEIGHT(KG)	MATERIAL	QTY.
1	BF-01-01-02-05-01	pipe-ANSI B36.19-1inx 1.65mmL:600mm-welded Pipe	0.6	ST37	3
2	BF-01-01-04-02-01	pipe-ANSI B36.19-1inx 1.65mmL:1933mm-welded Pipe	2.5	ST37	4
3	BF-01-01-02-05-06	1 in welded elbow (90 degree)	0.1	ST37	8
4	BF-01-01-02-05-03	pipe-ANSI B36.19-1inx 1.65mmL:398.4mm-welded Pipe	0.5	ST37	4
5	BF-01-01-02-05-07	Bag filter hand rail plate.01 (100mm x 45 mm x 6 mm)	0.2	ST37	3
6	BF-01-01-02-05-04	pipe-ANSI B36.19-1inx 1.65mmL:441mm-welded Pipe	0.6	ST37	6
7	BF-01-01-02-05-04	pipe-ANSI B36.19-1inx 1.65mmL:94mm-welded Pipe	0.1	ST37	3

ANG.PROJ.:				
TELORANCE:	ISO 2768-1 (Tolerance Class m) ISO 2768-2 (Tolerance Class k) ISO 13920 (Tolerance Class A)			گروه صنایع سیمان کرمان (سهامی عام)
UNIT: mm, kg	نام: _____ نام: M.H.Izadi نام: M.S.Arabnejad نام: A.Anjomshoa			عنوان: Bag filter hand rail part.04 شماره: BF-01-01-04-02 شناسه: **
Document Type: Part	نام: _____ نام: M.H.Izadi نام: M.S.Arabnejad نام: A.Anjomshoa			شماره: BF-01-01-04-02 شناسه: **
QTY.: ***	نام: _____ نام: M.H.Izadi نام: M.S.Arabnejad نام: A.Anjomshoa			شماره: BF-01-01-04-02 شناسه: **
Revision:	نام: _____ نام: M.H.Izadi نام: M.S.Arabnejad نام: A.Anjomshoa			شماره: BF-01-01-04-02 شناسه: **
Revision Date:	نام: _____ نام: M.H.Izadi نام: M.S.Arabnejad نام: A.Anjomshoa			شماره: BF-01-01-04-02 شناسه: **
Classification:	نام: _____ نام: M.H.Izadi نام: M.S.Arabnejad نام: A.Anjomshoa			شماره: BF-01-01-04-02 شناسه: **
	وزن: 18.8 Kg			مقیاس: 1:10 برگه: 14 of 61 سایز: A3

8 7 6 5 4 3 2 1

F
E
D
C
B
A

F
E
D
C
B
A

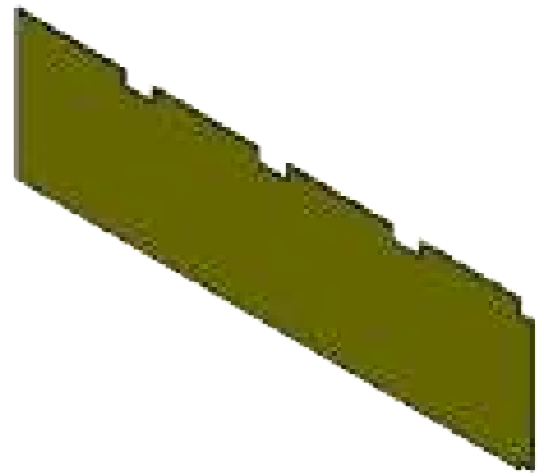
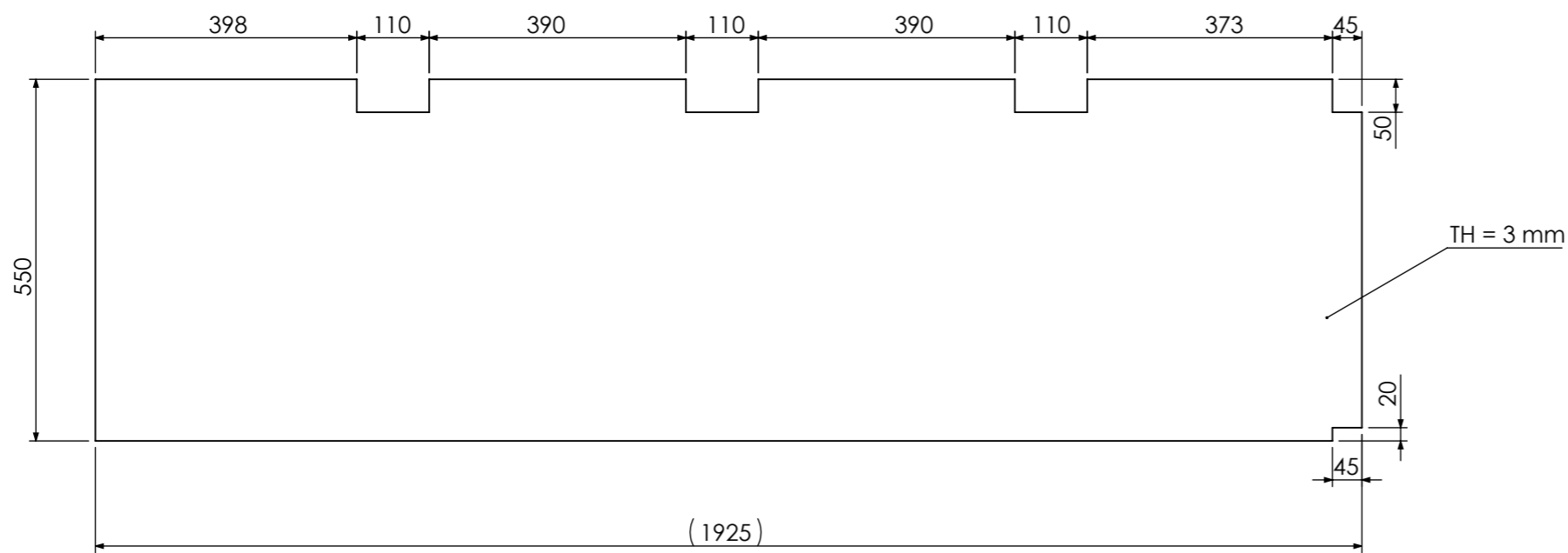

Bag filter walk way Plate.04
BF-01-01-04-03

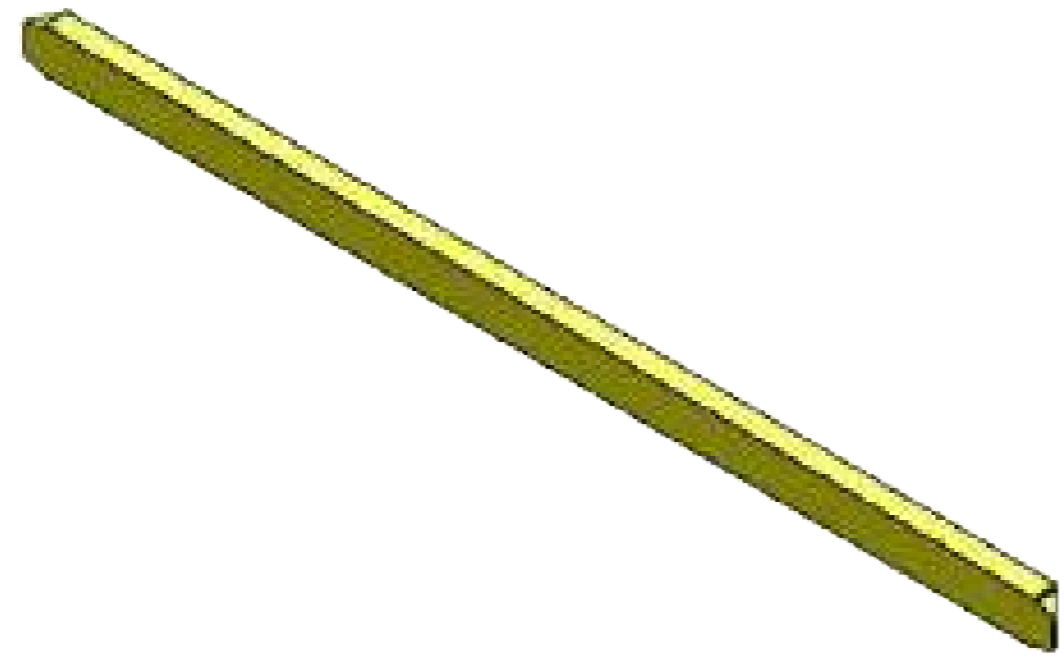
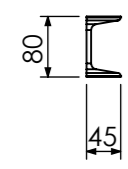
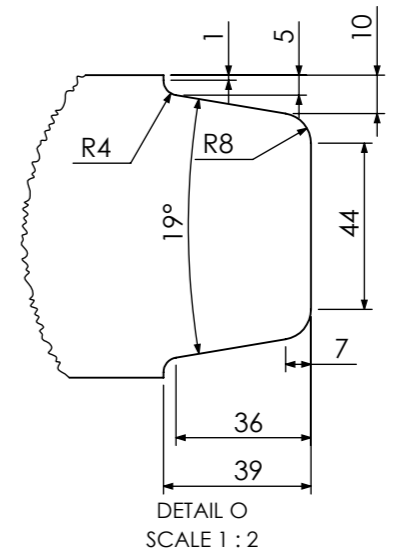
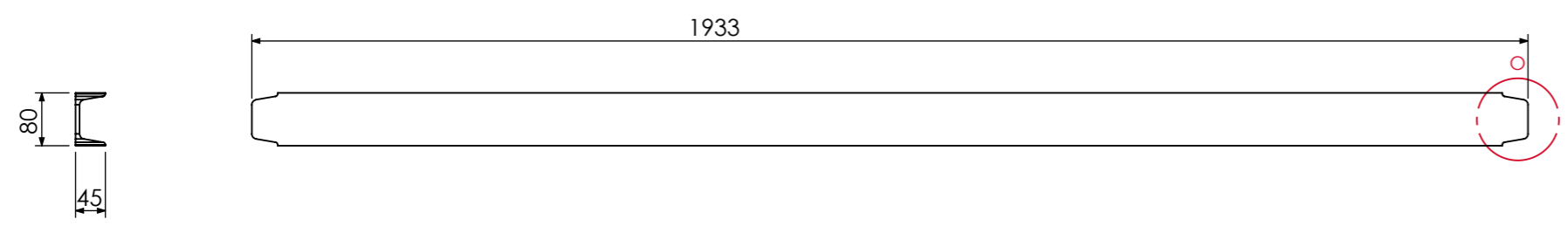

Bag filter walk way UPN80.07
BF-01-01-04-01

ANG.PROJ.:	گروه صنایع سیمان کرمان (سهامی عام)			
ISO 2768-1 (Tolerance Class m) TOLERANCE: ISO 2768-2 (Tolerance Class k) ISO 13920 (Tolerance Class A)	UNIT: mm, kg	Document Type: Part	DRAWN: M.H.Izadi CHECKED: M.S.Arabnejad APPROVED: A.Anjomshoa	TITLE: Bag filter walk way Plate.04 Bag filter walk way UPN80(02-07) PART NO.: BF-01-04-(01-03) Document ID: **
Revision:	Material: --	REF. Document ID:	Scale: 1:10	Record ID:
Revision Date:	WEIGHT: 16.6 Kg	Sheet: 15 of 61	Size: A3	

8 7 6 5 4 3 2 1

8 7 6 5 4 3 2 1

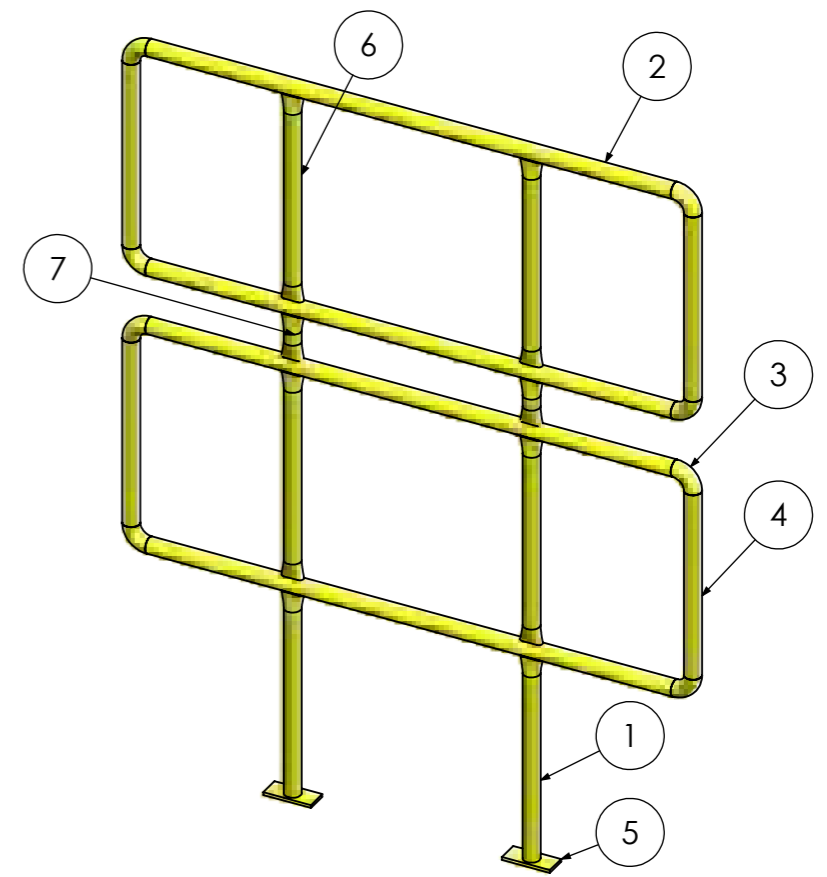
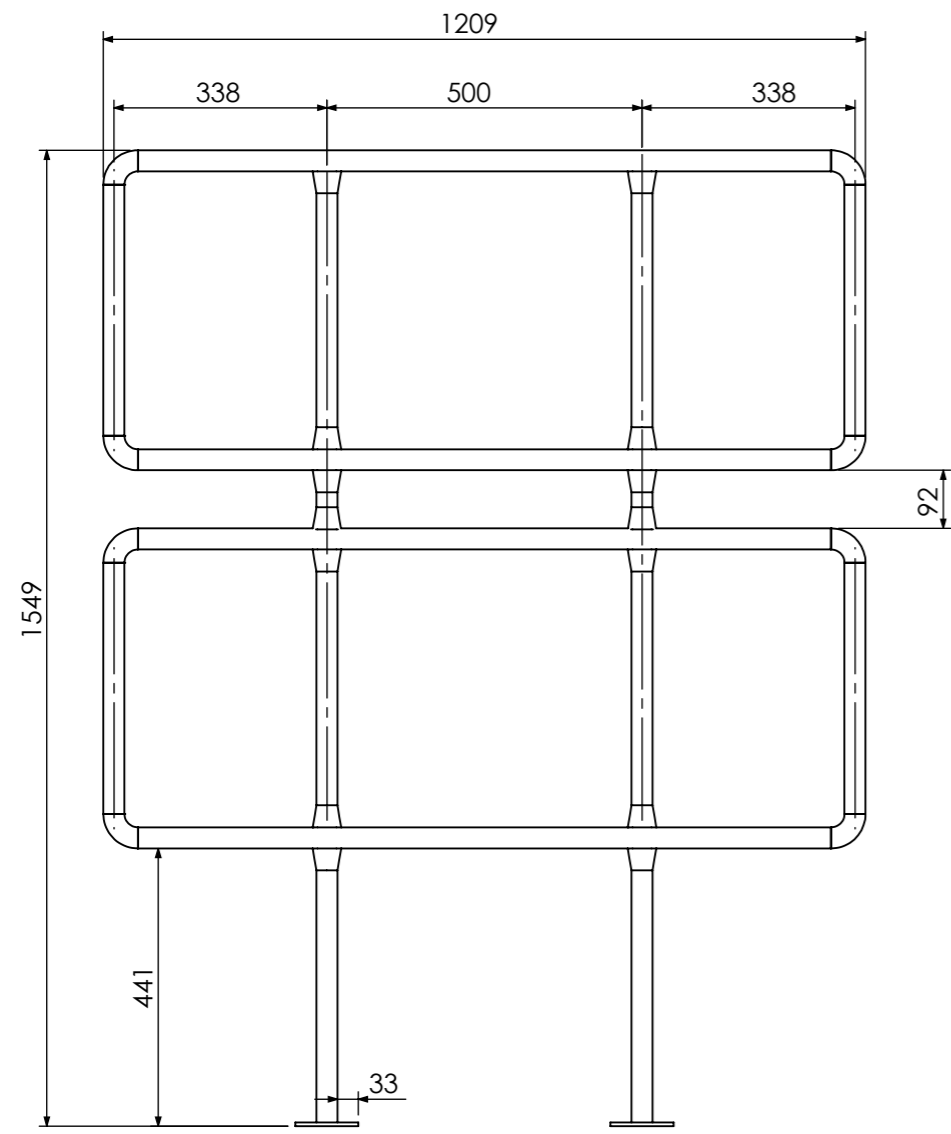

ITEM NO.	PART NUMBER	PART NAME	WEIGHT(KG)	MATERIAL	QTY.
1	BF-01-01-02-05-01	pipe-ANSI B36.19-1inx 1.65mmL:600mm-welded Pipe	0.6	ST37	2
2	BF-01-01-05-01	pipe-ANSI B36.19-1inx 1.65mmL:1100mm-welded Pipe	1.4	ST37	4
3	BF-01-01-02-05-06	1 in welded elbow (90 degree)	0.1	ST37	8
4	BF-01-01-02-05-03	pipe-ANSI B36.19-1inx 1.65mmL:398.4mm-welded Pipe	0.5	ST37	4
5	BF-01-01-02-05-07	Bag filter hand rail plate.01 (100mm x 45 mm x 6 mm)	0.2	ST37	2
6	BF-01-01-02-05-04	pipe-ANSI B36.19-1inx 1.65mmL:441mm-welded Pipe	0.6	ST37	4
7	BF-01-01-02-05-04	pipe-ANSI B36.19-1inx 1.65mmL:94mm-welded Pipe	0.1	ST37	2

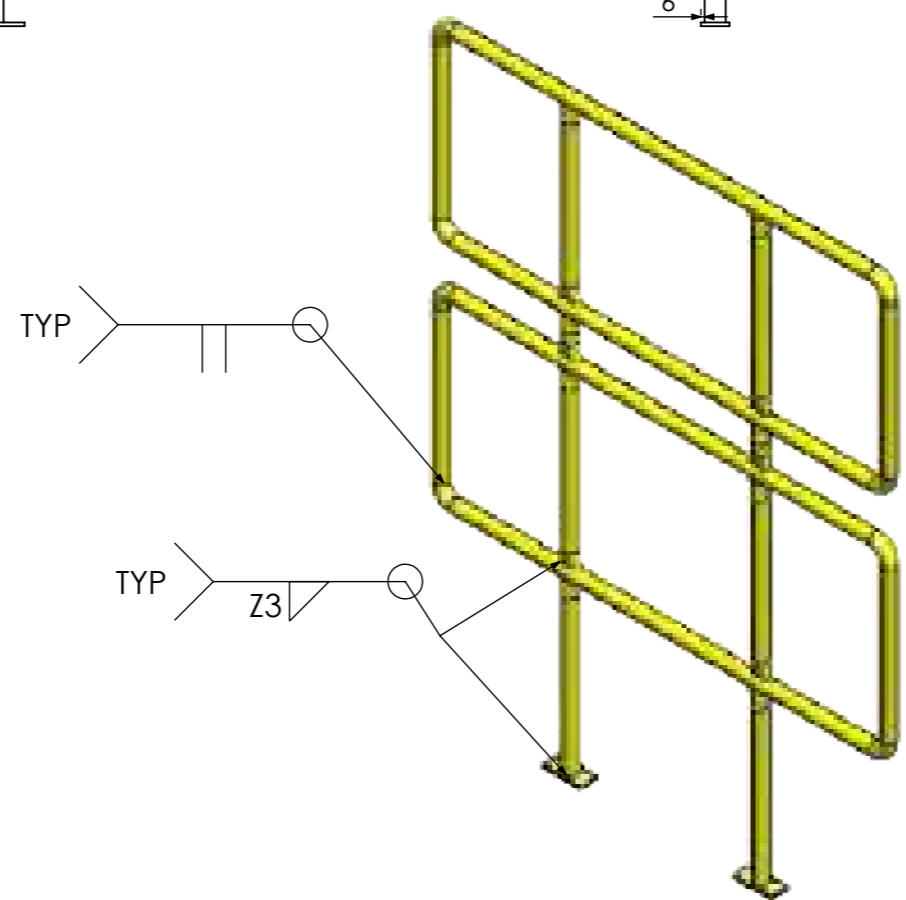

ANG.PROJ.:

TELORANCE: ISO 2768-1 (Tolerance Class m) ISO 2768-2 (Tolerance Class k) ISO 13920 (Tolerance Class A)

UNIT: mm, kg

Document Type: **Assem**

QTY.: ***

Revision:
 Revision Date:
 Classification:

NAME: M.H.Izadi
 SIGNATURE:
 DATE:
 TITLE: **Bag filter hand rail part.01**

PART NO.: BF-01-01-05
 Document ID: **

REF. Document ID:
 Record ID:

WEIGHT: 12.4 Kg
 Scale: 1:10
 Sheet: 16 of 61
 Size: A3

8 7 6 5 4 3 2 1

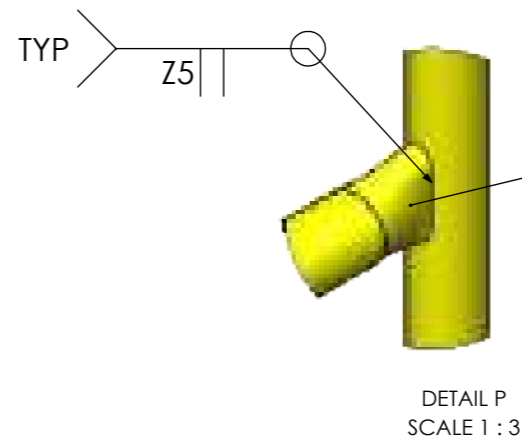
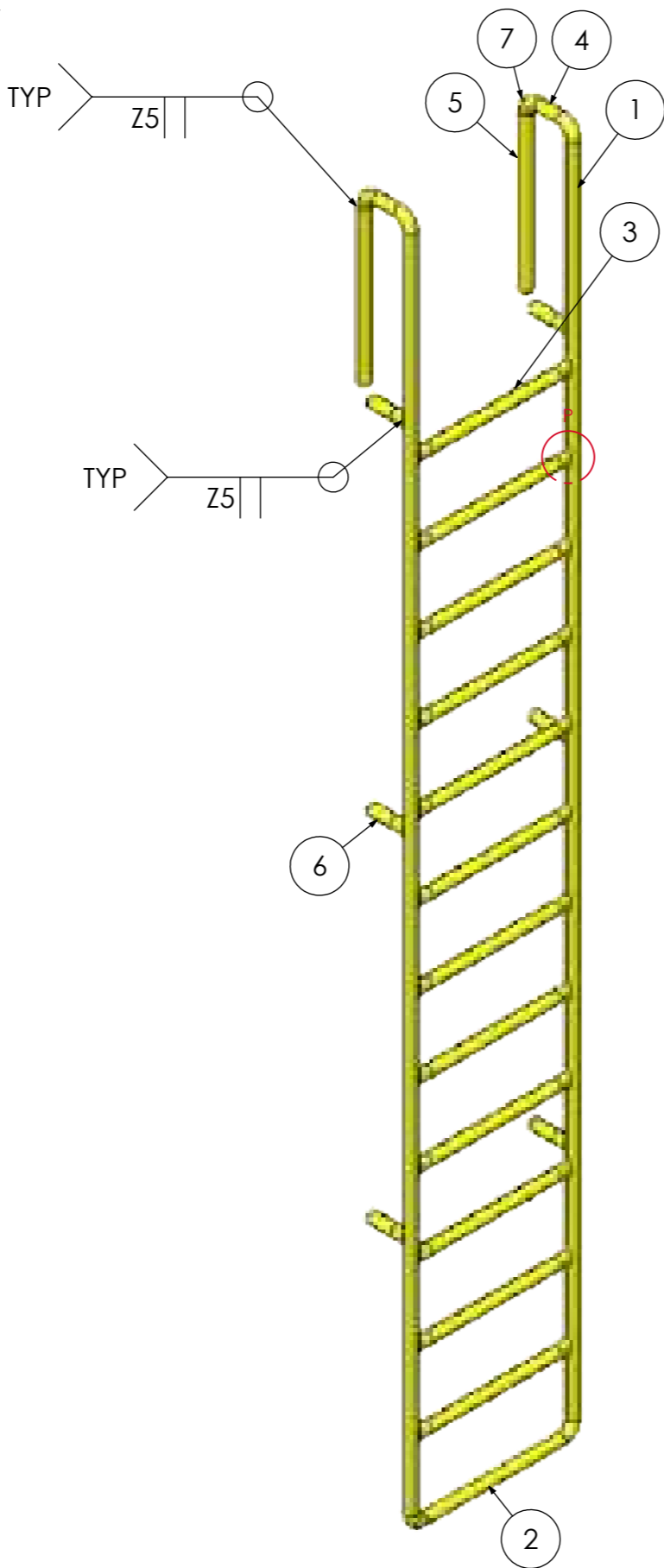
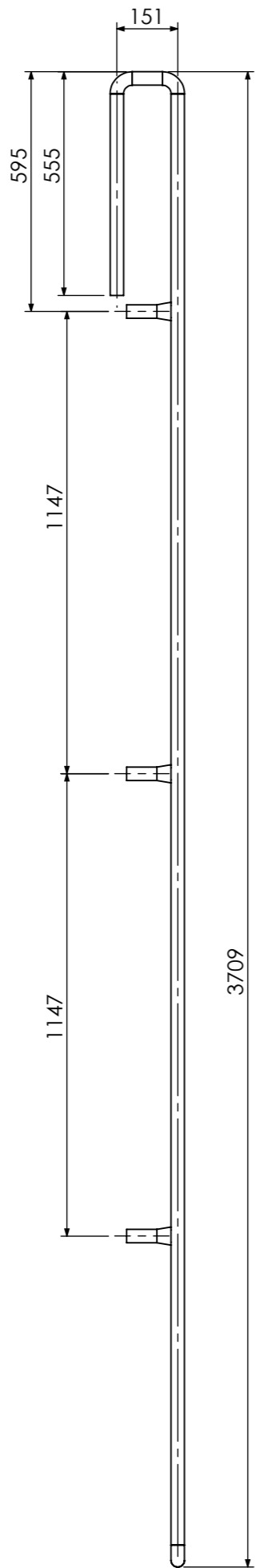
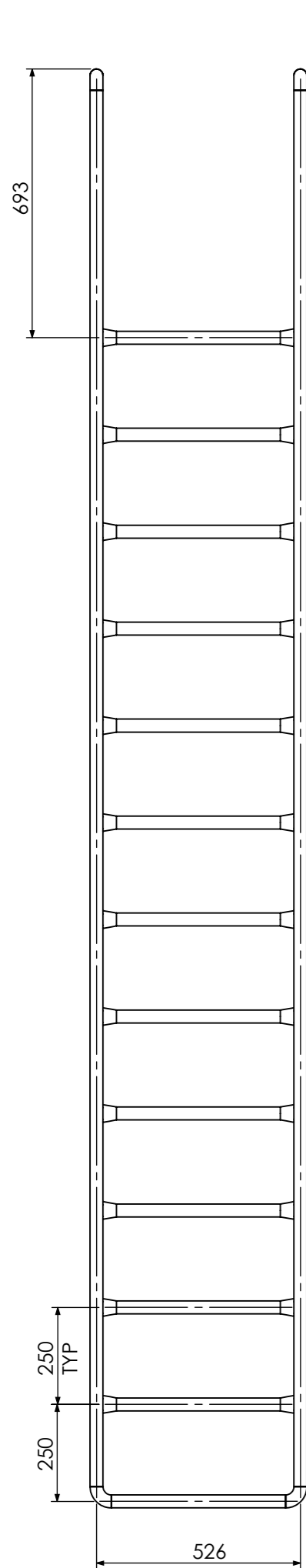

ITEM NO.	PART NUMBER	PART NAME	WEIGHT(KG)	MATERIAL	QTY.
1	BF-01-01-06-01	pipe-ANSI B36.19-1inx 1.65mmL:3600mm-welded Pipe	4.7	ST37	2
2	BF-01-01-06-02	pipe-ANSI B36.19-1inx 1.65mmL:450mm-welded Pipe	0.6	ST37	1
3	BF-01-01-06-03	pipe-ANSI B36.19-1inx 1.65mmL:492.6mm-welded Pipe	0.6	ST37	12
4	BF-01-01-06-04	pipe-ANSI B36.19-1inx 1.65mmL:75mm-welded Pipe	0.1	ST37	2
5	BF-01-01-06-05	pipe-ANSI B36.19-1inx 1.65mmL:500mm-welded Pipe	0.6	ST37	2
6	BF-01-01-06-06	pipe-ANSI B36.19-1inx 1.65mmL:110mm-welded Pipe	0.1	ST37	6
7	BF-01-01-02-05-06	1 in welded elbow (90 degree)	0.1	ST37	6

ANG.PROJ.:	گروه صنایع سیمان کرمان (سهامی عام)			
ISO 2768-1 (Tolerance Class m) ISO 2768-2 (Tolerance Class k) ISO 13920 (Tolerance Class A)				
UNIT: mm, kg	کارخانه			
Document Type: Assem	NAME	SIGNATURE	DATE	TITLE: Bag filter ladder Part.01
QTY.: ***	CHECKED	M.S.Arabnejad		PART NO.: BF-01-01-06
	APPROVED	A.Anjomshoa		Document ID: **
Revision:				REF. Document ID:
Revision Date:	Material: --			Record ID:
Classification:	WEIGHT: 20.3 Kg	Scale: 1:20	Sheet: 17 of 61	Size: A3

8 7 6 5 4 3 2 1

F

F

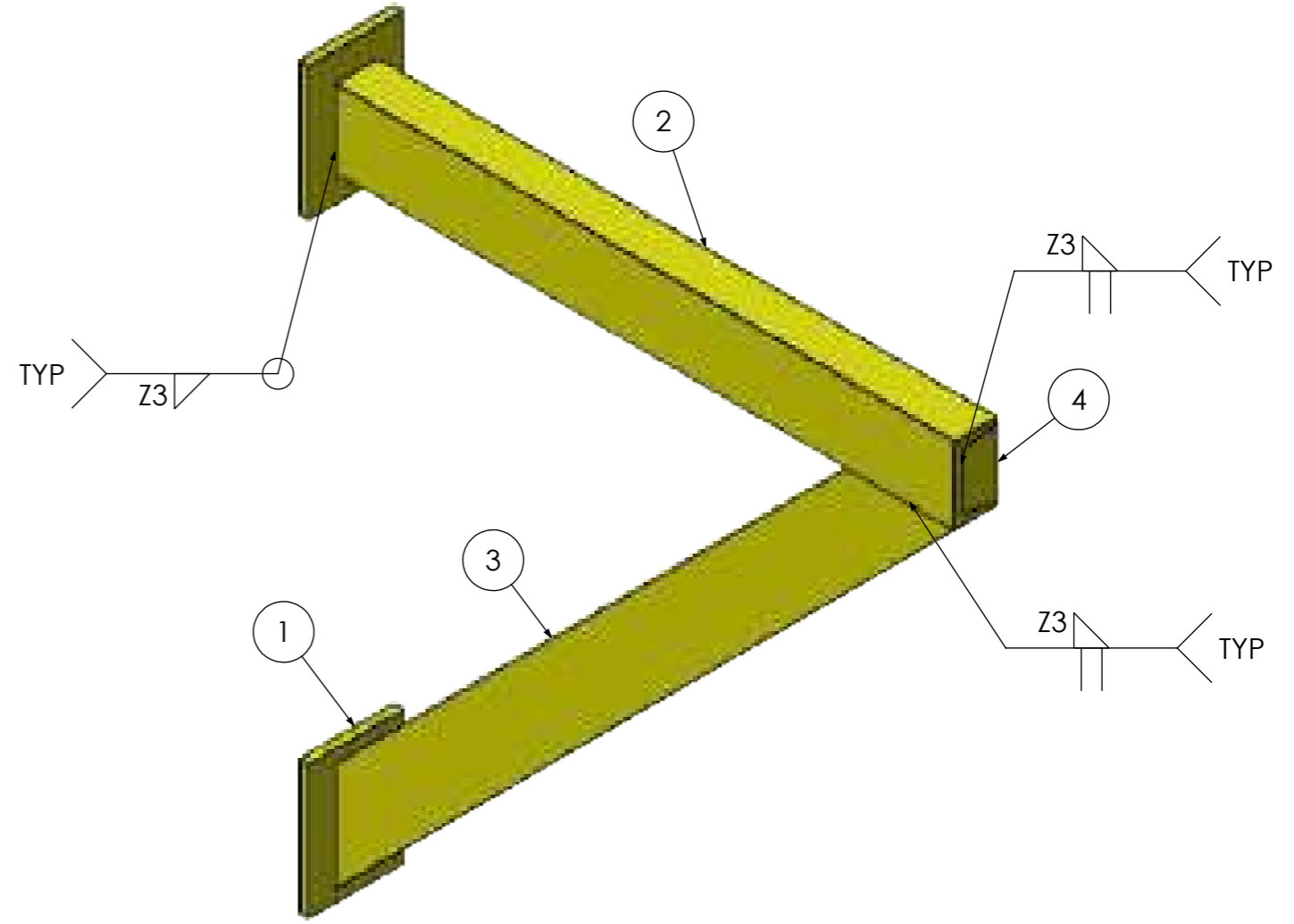
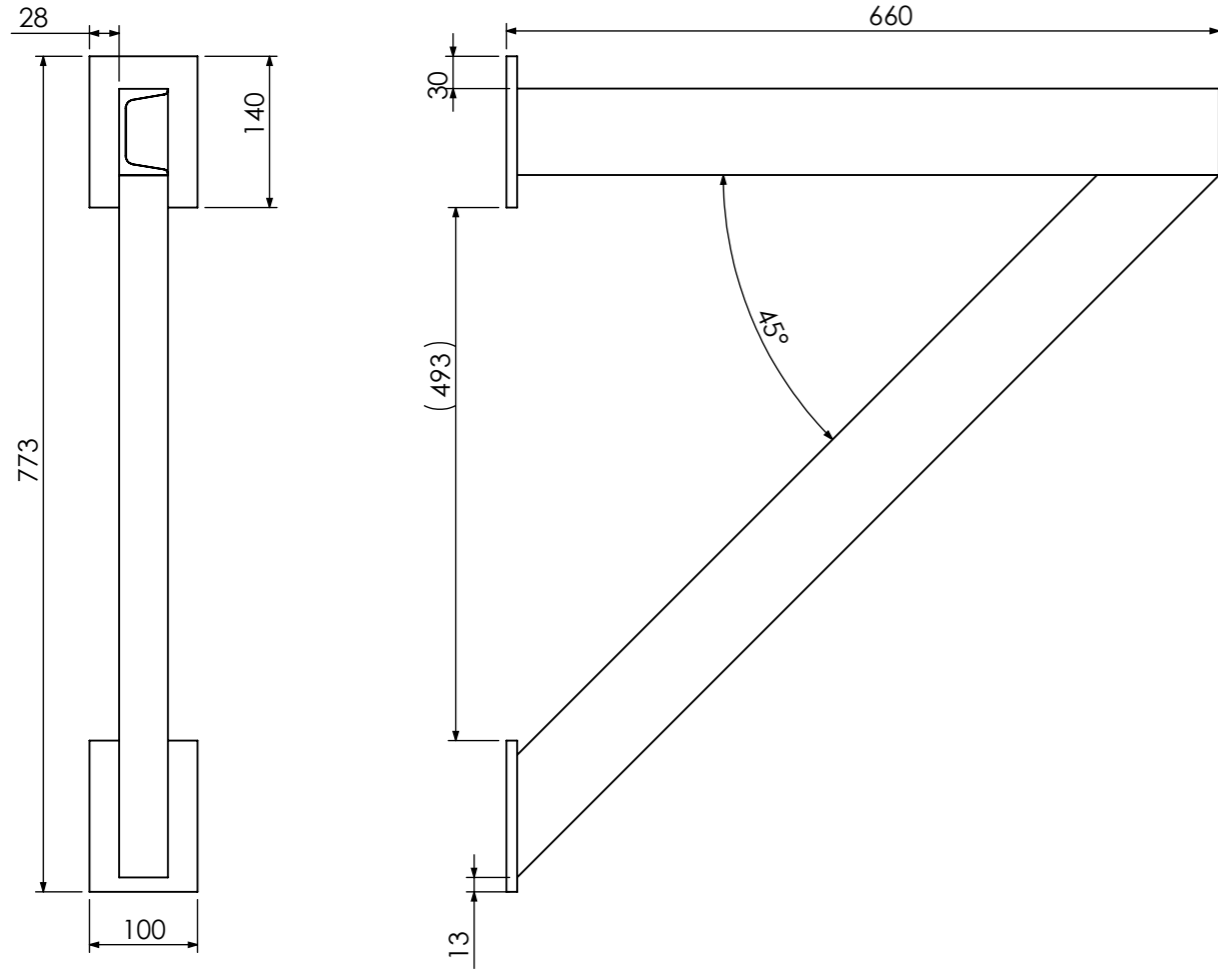

E

E

D

D

C

C

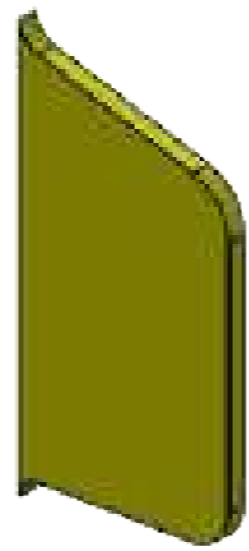
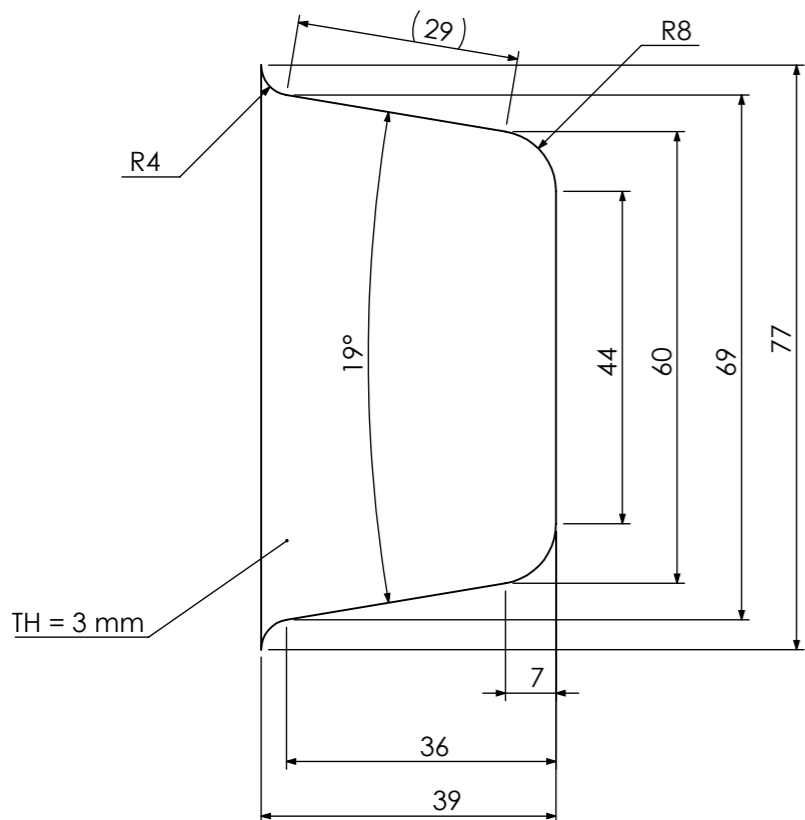

Bag filter ladder structure plate.01
BF-01-01-07-01

ITEM NO.	PART NUMBER	PART NAME	WEIGHT(KG)	MATERIAL	QTY.
1	BF-01-01-02-04	Bag filter walk way Plate.01 (100mm x 140 mm x 10 mm)	1.1	ST37	2
2	BF-01-01-02-01	Bag filter walk way UPN80.01 (L=650 simple)	5.7	ST37	1
3	BF-01-01-02-02	Bag filter walk way UPN80.02	7.4	ST37	1
4	BF-01-01-07-01	Bag filter ladder structure plate.01	0.1	ST37	1

ANG.PROJ.:	گروه صنایع سیمان کرمان (سهامی عام)			
ISO 2768-1 (Tolerance Class m) TELORANCE: ISO 2768-2 (Tolerance Class k) ISO 13920 (Tolerance Class A)				
UNIT: mm, kg	NAME	SIGNATURE	DATE	TITLE:
Document Type: Assem	DRAWN: M.H.Izadi			Bag filter ladder structure part.01 Bag filter ladder structure plate.01
QTY.: ***	CHECKED: M.S.Arabnejad			PART NO.: BF-01-01-07 BF-01-01-07-01
	APPROVED: A.Anjomshoa			Document ID: **
Revision:				REF. Document ID:
Revision Date:	Material: --			Record ID:
Classification:	WEIGHT: 30.6 Kg	Scale: 1:20		Sheet: 18 of 61
				Size: A3

8 7 6 5 4 3 2 1

A

A

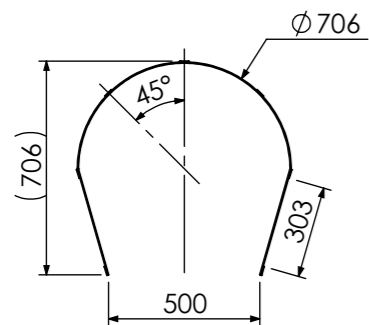
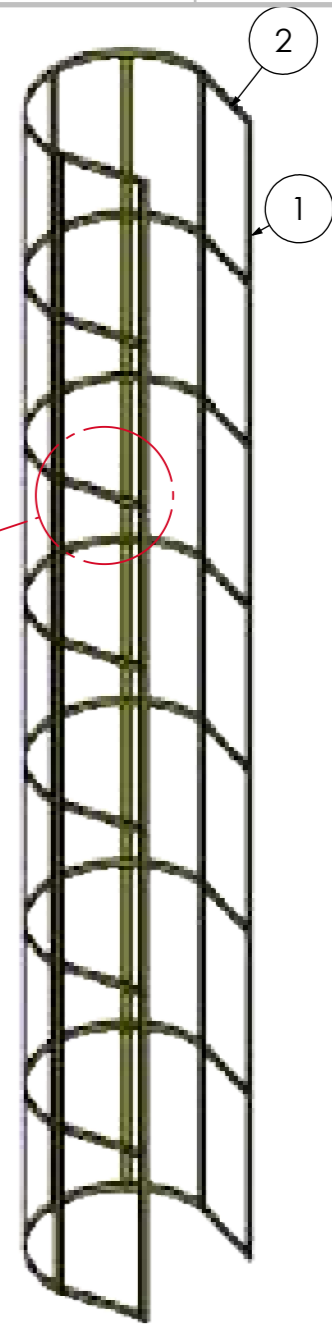
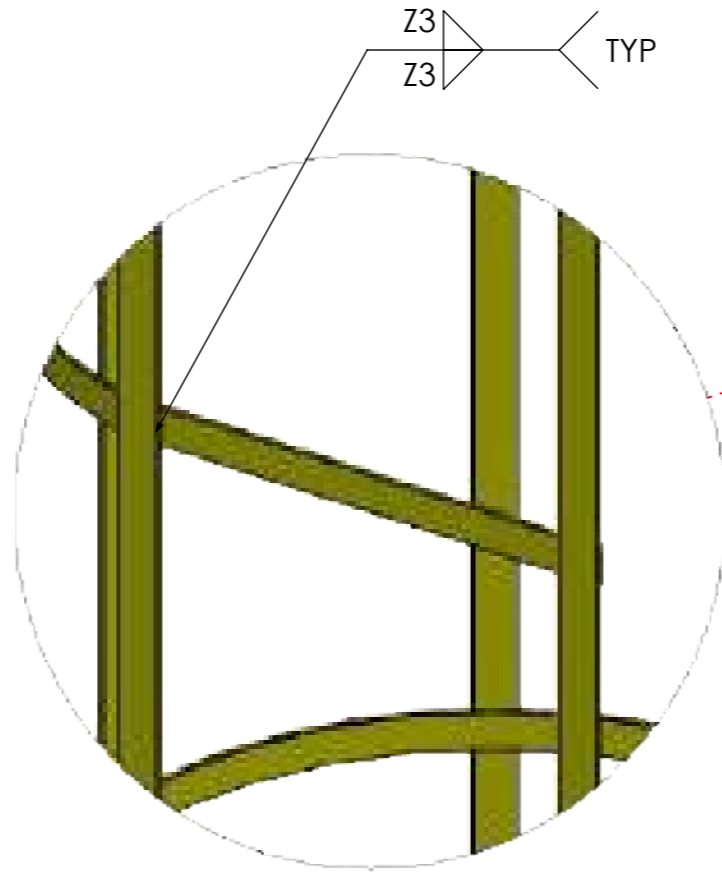
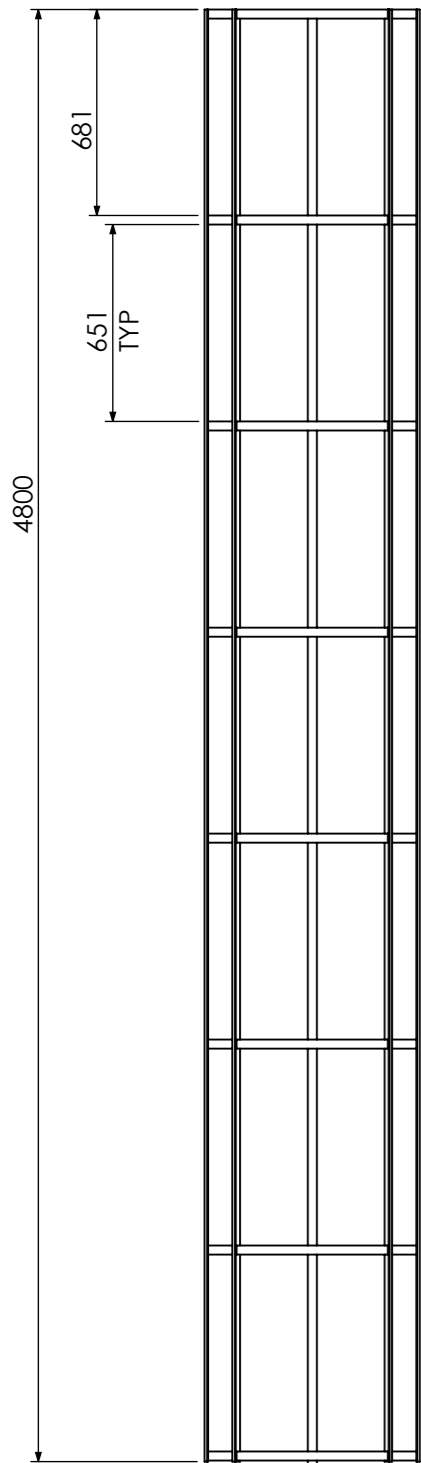

ITEM NO.	PART NUMBER	PART NAME	WEIGHT(KG)	MATERIAL	QTY.
1	BF-01-01-08-01	Bag filter ladder safety cage plate.01 (3600mm x 30mm x 3mm)	3.4	ST37	7
2	BF-01-01-08-02	Bag filter ladder safety cage plate.02	1.3	ST37	8

ANG.PROJ.:	گروه صنایع سیمان کرمان (سهامی عام)			
<small>ISO 2768-1 (Tolerance Class m)</small> <small>TELORANCE: ISO 2768-2 (Tolerance Class k)</small> <small>ISO 13920 (Tolerance Class A)</small>				
UNIT: mm, kg	NAME	SIGNATURE	DATE	TITLE:
Document Type: Assem	DRAWN: M.H.Izadi			Bag filter ladder safety cage Part.01
QTY.: ***	CHECKED: M.S.Arabnejad			PART NO.: BF-01-01-08
	APPROVED: A.Anjomshoa			Document ID: **
Revision:				REF. Document ID:
Revision Date:	Material: --			Record ID:
Classification:	WEIGHT: 34.1 Kg	Scale: 1:50	Sheet: 19 of 61	Size: A3

8 7 6 5 4 3 2 1

F
E
D
C
B
A

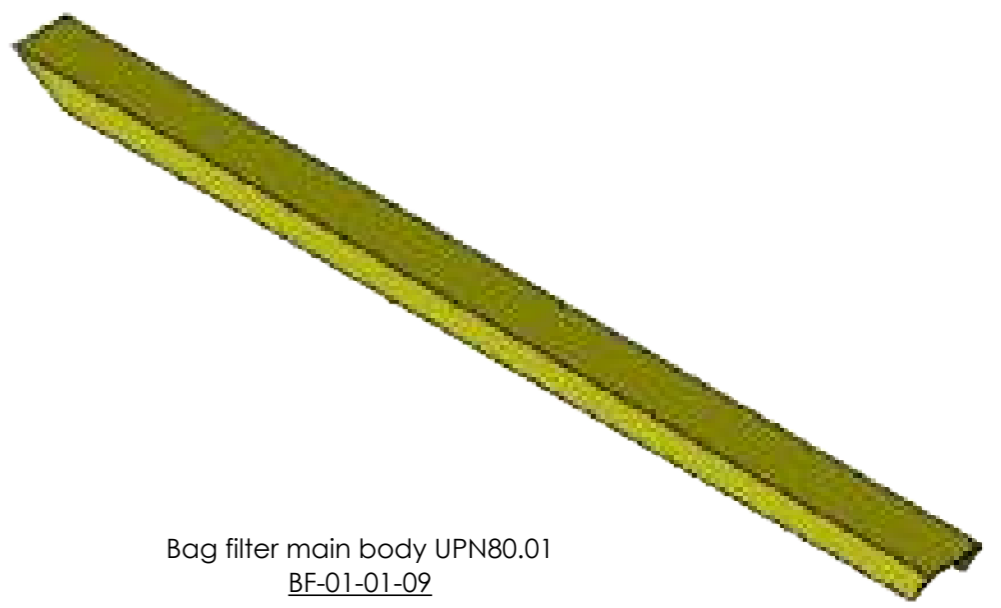
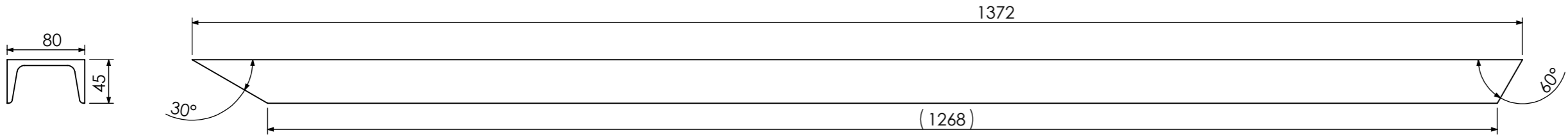

Bag filter main body UPN80.01
BF-01-01-09

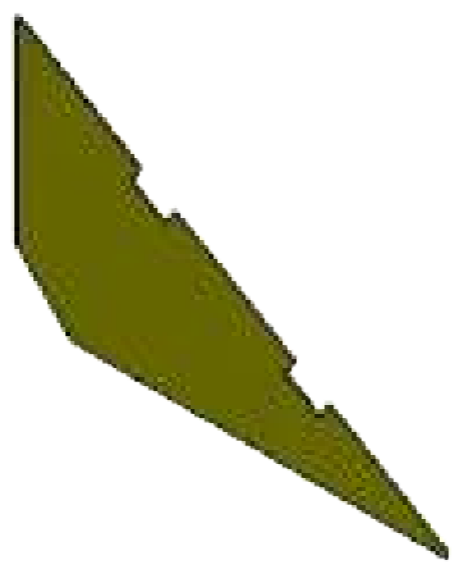
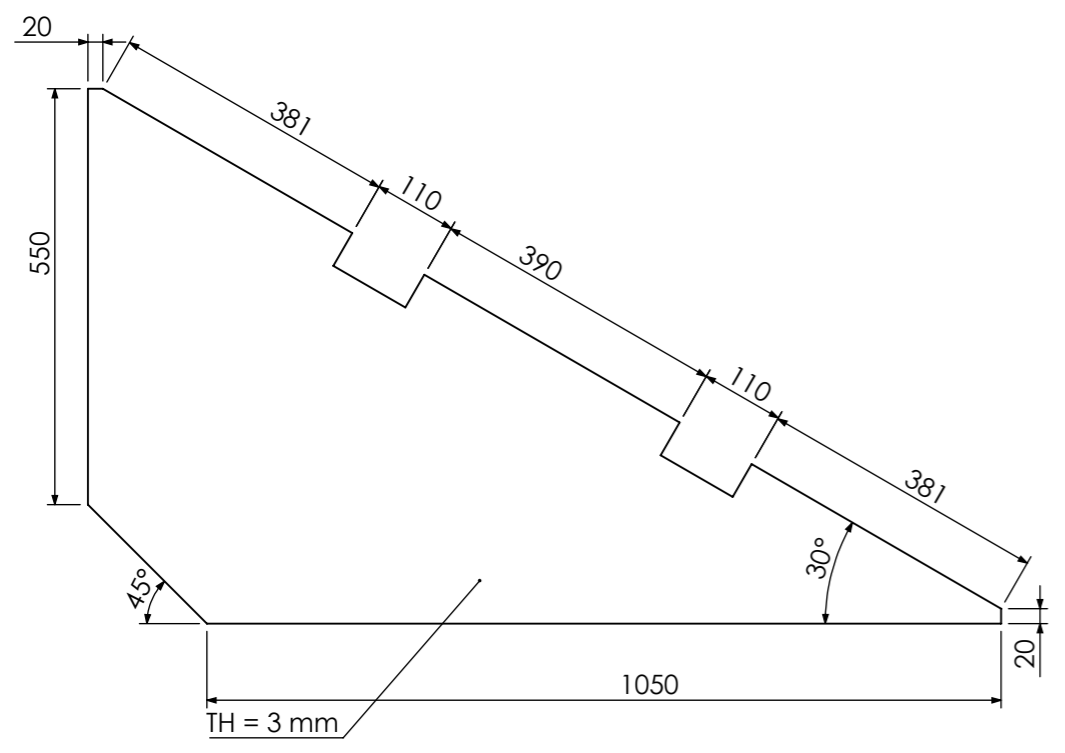

Bag filter main body plate.01
BF-01-01-10

ANG.PROJ.:		گروه صنایع سیمان کرمان (سهامی عام)			
TELORANCE:	<small>ISO 2768-1 (Tolerance Class m)</small> <small>ISO 2768-2 (Tolerance Class k)</small> <small>ISO 13920 (Tolerance Class A)</small>				
UNIT: mm, kg					
Document Type: Part		NAME	SIGNATURE	DATE	TITLE:
	DRAWN	M.H.Izadi			Bag filter main body UPN80.01 Bag filter main body plate.01
QTY.: ***	CHECKED	M.S.Arabnejad			PART NO.: BF-01-01-(09-10)
	APPROVED	A.Anjomshoa			Document ID: **
Revision:					REF. Document ID:
Revision Date:	Material: --				Record ID:
Classification:	WEIGHT: 11.8 Kg	Scale: 1:10		Sheet: 20 of 61	Size: A3

8 7 6 5 4 3 2 1

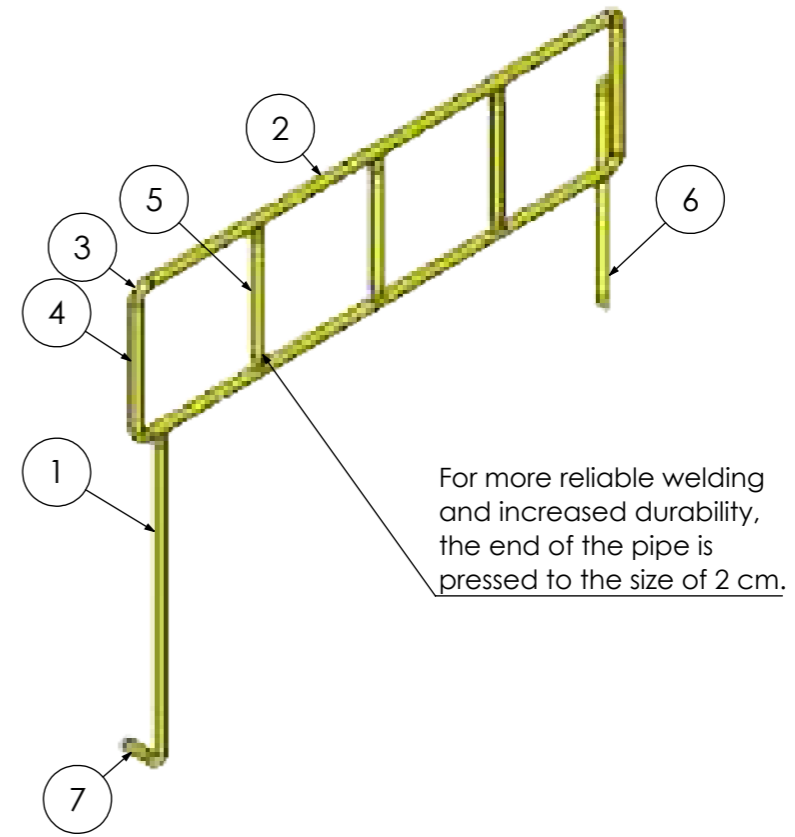
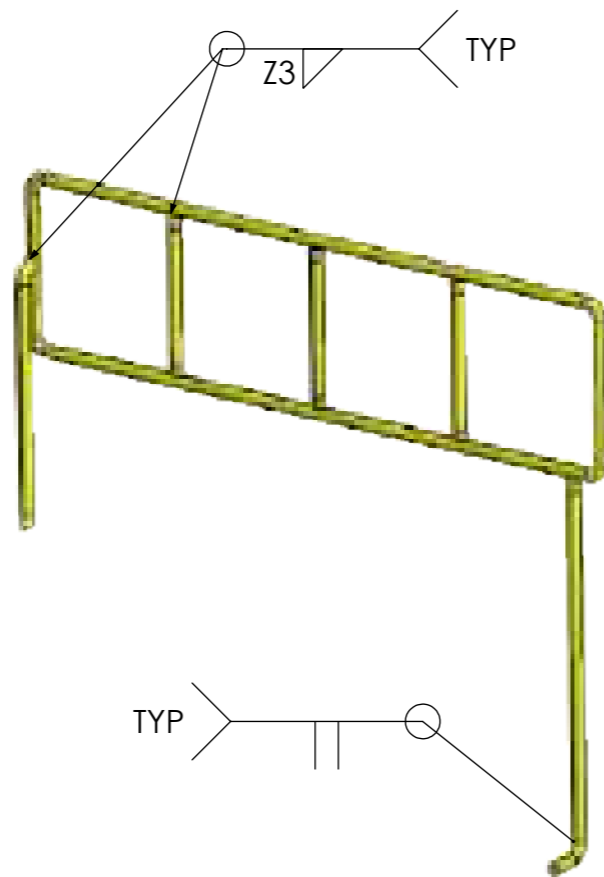
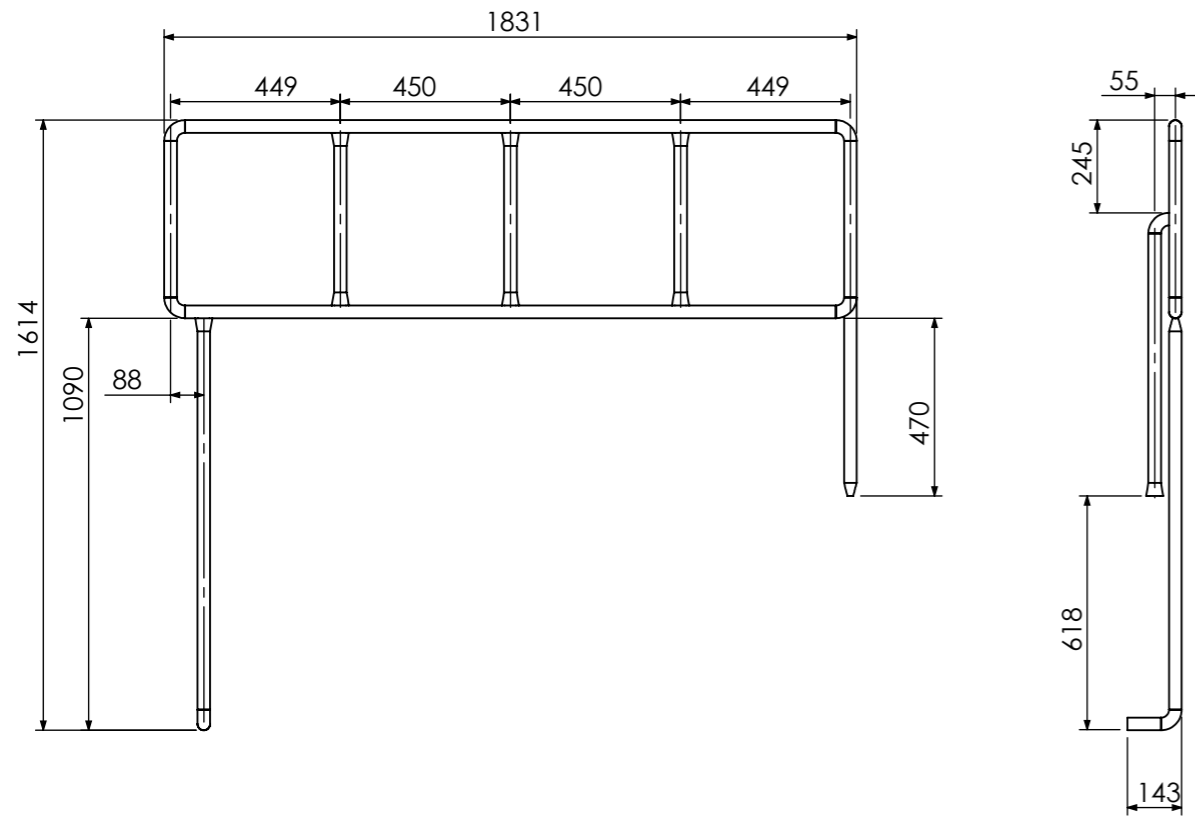

ITEM NO.	PART NUMBER	PART NAME	WEIGHT(KG)	MATERIAL	QTY.
1	BF-01-01-11-01	pipe-ANSI B36.19-1inx 1.65mmL:1035mm-welded Pipe	1.3	ST37	1
2	BF-01-01-11-02	pipe-ANSI B36.19-1inx 1.65mmL:1722mm-welded Pipe	2.2	ST37	2
3	BF-01-01-02-05-06	1 in welded elbow (90 degree)	0.1	ST37	6
4	BF-01-01-11-03	pipe-ANSI B36.19-1inx 1.65mmL:415mm-welded Pipe	0.5	ST37	2
5	BF-01-01-11-04	pipe-ANSI B36.19-1inx 1.65mmL:457mm-welded Pipe	0.6	ST37	3
6	BF-01-01-11-05	pipe-ANSI B36.19-1inx 1.65mmL:695mm-welded Pipe	0.9	ST37	1
7	BF-01-01-11-06	pipe-ANSI B36.19-1inx 1.65mmL:89mm-welded Pipe	0.1	ST37	1

ANG.PROJ.:	گروه صنایع سیمان کرمان (سهامی عام)			
ISO 2768-1 (Tolerance Class m) TELORANCE: ISO 2768-2 (Tolerance Class k) ISO 13920 (Tolerance Class A)				
UNIT: mm, kg				
Document Type: Assem	NAME	SIGNATURE	DATE	TITLE:
	DRAWN: M.H.Izadi			Bag filter hand rail part.05
QTY.: ***	CHECKED: M.S.Arabnejad			PART NO.: BF-01-01-11
	APPROVED: A.Anjomshoa			Document ID: **
Revision:				REF. Document ID:
Revision Date:	Material: --			Record ID:
Classification:	WEIGHT: 10.1 Kg	Scale: 1:20	Sheet: 21 of 61	Size: A3

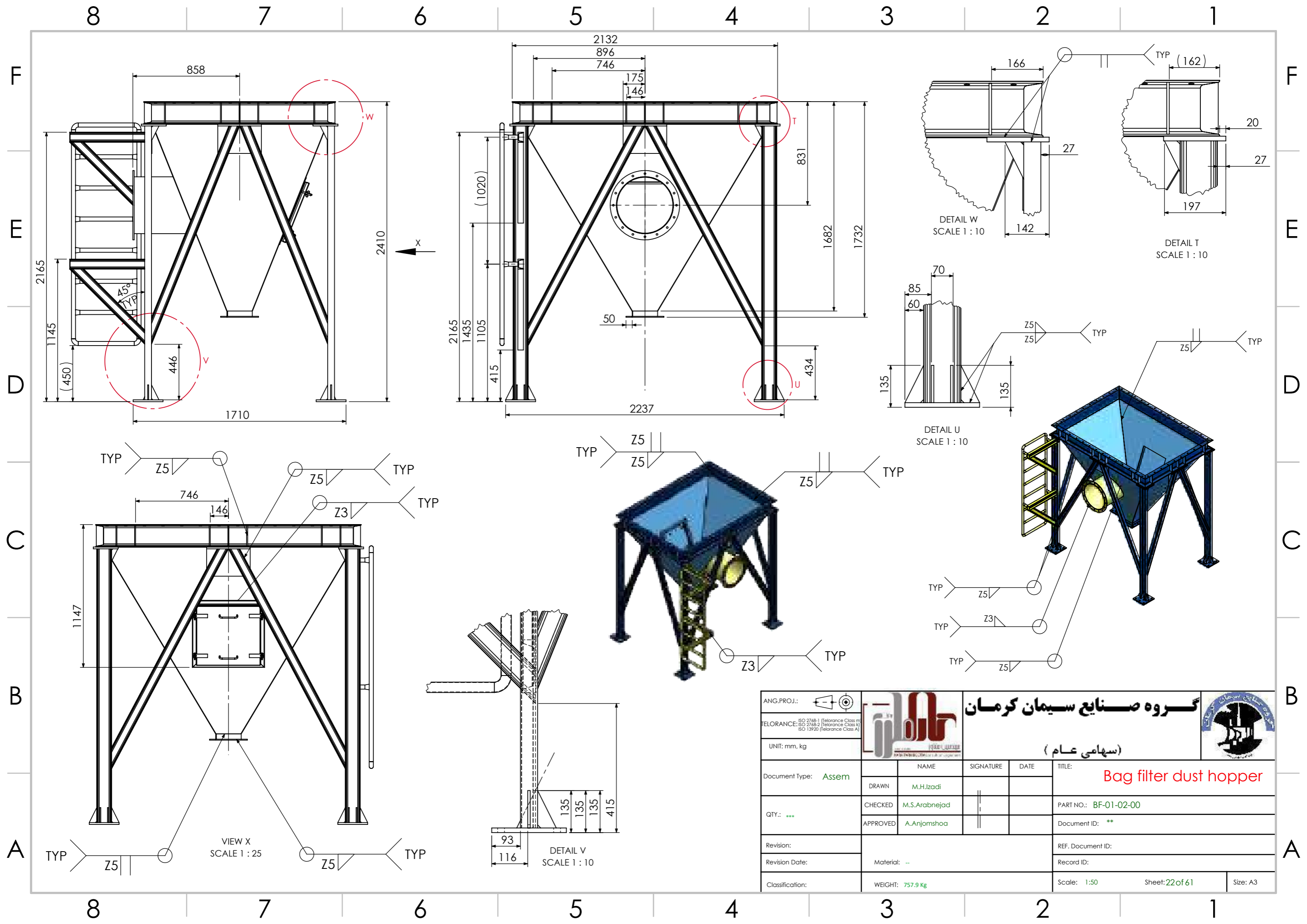

ANG.PROJ.:				گروه صنایع سیمان کرمان	
TELORANCE: ISO 2768-1 (Tolerance Class m) ISO 2768-2 (Tolerance Class k) ISO 13920 (Tolerance Class A)				(سهامی عام)	
UNIT: mm, kg				TITLE: Bag filter dust hopper	
Document Type: Assem	DRAWN	M.H.Izadi	SIGNATURE	DATE	PART NO.: BF-01-02-00
QTY.: ***	CHECKED	M.S.Arabnejad			Document ID: **
Revision:	APPROVED	A.Anjomshoa			REF. Document ID:
Revision Date:	Material: --				Record ID:
Classification:	WEIGHT: 757.9 Kg			Scale: 1:50	Sheet: 22 of 61
					Size: A3

ITEM NO.	PART NUMBER	PART NAME	WEIGHT(KG)	MATERIAL	QTY.
1	BF-01-02-01	Bag filter ladder structure part.02	26.3	--	1
2	BF-01-02-02	Bag filter ladder Part.02	10.2	--	1
3	BF-01-02-03	Bag filter dust hopper window	12.7	--	1
4	BF-01-02-04	Bag filter dust hopper plate.01	47.7	ST37	1
5	BF-01-02-05	Bag filter dust hopper plate.02	43.9	ST37	2
6	BF-01-02-06	Bag filter dust hopper plate.03	50.0	ST37	1
7	BF-01-02-07	Bag filter dust hopper UPN180.01	31.7	ST37	2
8	BF-01-02-08	Bag filter dust hopper UPN180.02	44.8	ST37	2
9	BF-01-02-09	Bag filter dust hopper plate.04 (200 mm x 50 mm x 4mm)	0.3	ST37	4
10	BF-01-02-10	Bag filter dust hopper plate.05	0.8	ST37	4
11	BF-01-02-11	Bag filter dust hopper UPN120.01 (L=2200mm simple)	29.7	ST37	4
12	BF-01-02-12	Bag filter dust hopper plate.06	3.2	ST37	4
13	BF-01-02-13	Bag filter dust hopper plate.07	6.5	ST37	4
14	BF-01-02-14	Bag filter dust hopper plate.08	0.2	ST37	28
15	BF-01-02-15	Bag filter dust hopper plate.09	0.2	ST37	4
16	BF-01-02-16	Bag filter dust hopper plate.10	0.6	ST37	24
17	BF-01-02-17	Bag filter dust hopper plate.11	6.1	ST37	1
18	BF-01-02-18	Bag filter dust hopper pipe 18 in.01	19.4	ST37	1
19	BF-01-02-19	Bag filter dust hopper plate.12 (350 mm x 85 mm x 15mm)	3.5	ST37	4
20	BF-01-02-20	Bag filter dust hopper UPN80.01	16.7	ST37	2
21	BF-01-02-21	Bag filter dust hopper UPN80.02	15.6	ST37	2
22	BF-01-02-22	Bag filter dust hopper UPN80.03	16.7	ST37	2
23	BF-01-02-23	Bag filter dust hopper UPN80.04	15.6	ST37	2
24	BF-01-02-24	Bag filter dust hopper plate.13 (350 mm x 220 mm x 8mm)	4.8	ST37	4

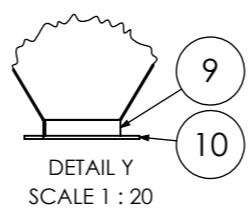
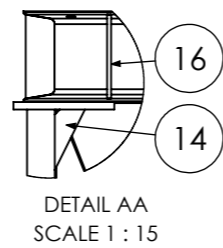
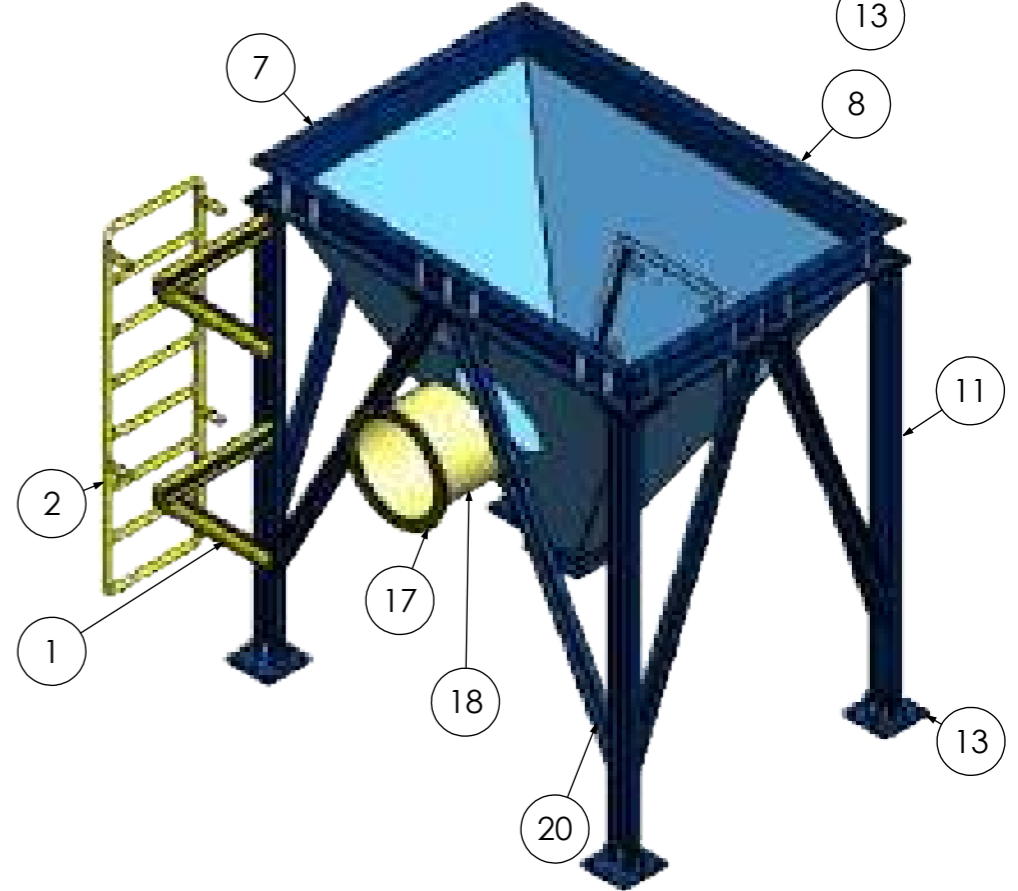
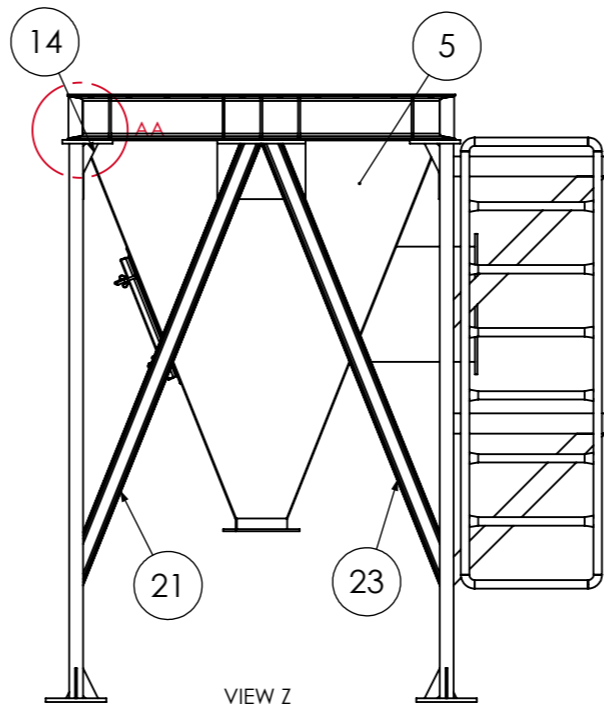
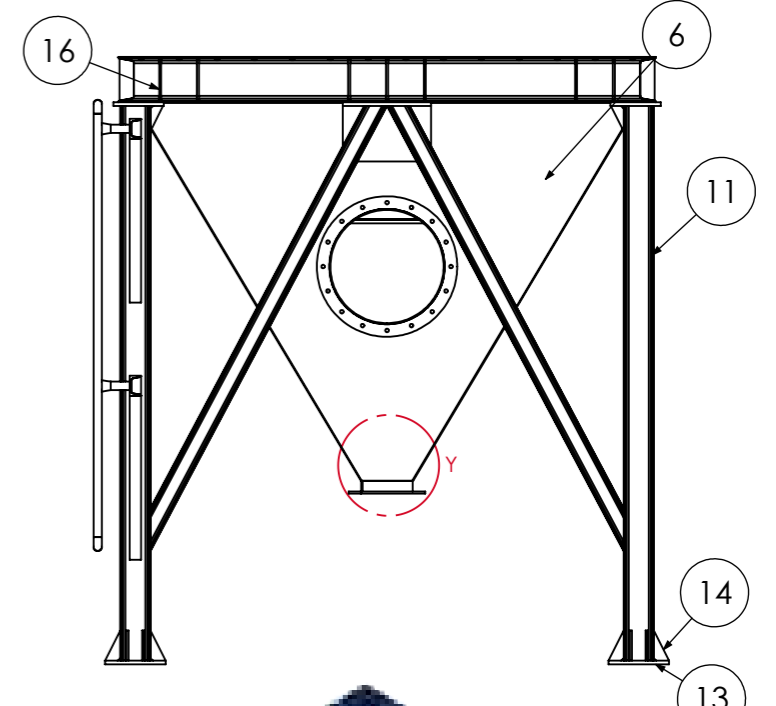
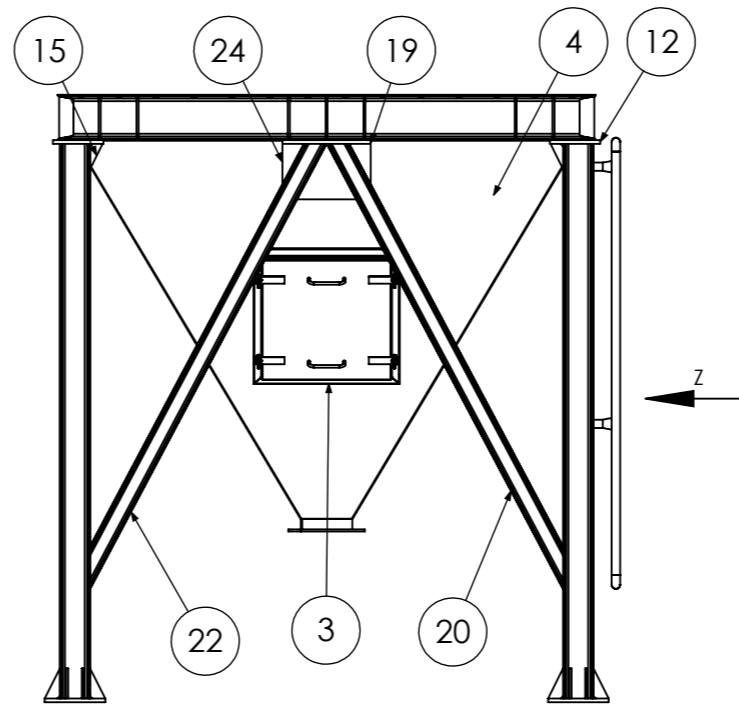

ANG.PROJ.:				گروه صنایع سیمان کرمان		
TELERANCE: ISO 2768-1 (Tolerance Class m) ISO 2768-2 (Tolerance Class k) ISO 13920 (Tolerance Class A)						
UNIT: mm, kg						(سهامی عام)
Document Type: Assem	NAME	SIGNATURE	DATE	TITLE: Bag filter dust hopper		
QTY.: ***	DRAWN: M.H.Izadi			PART NO.: BF-01-02-00		
	CHECKED: M.S.Arabnejad			Document ID: **		
	APPROVED: A.Anjomshoa					
Revision:				REF. Document ID:		
Revision Date:	Material: --			Record ID:		
Classification:	WEIGHT: 757.9 Kg			Scale: 1:50	Sheet: 23 of 61	Size: A3

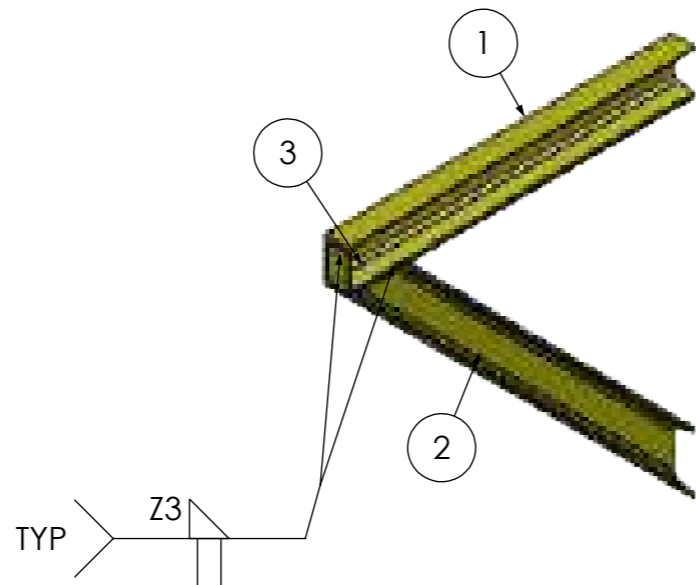
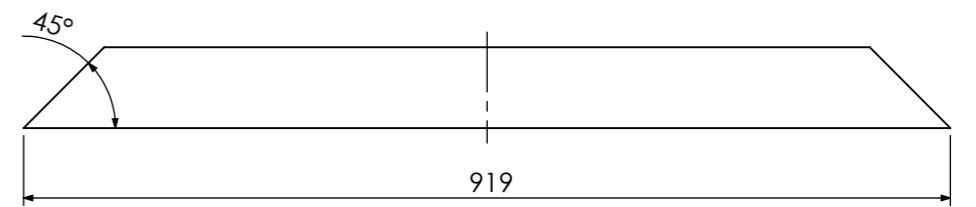
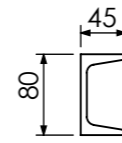
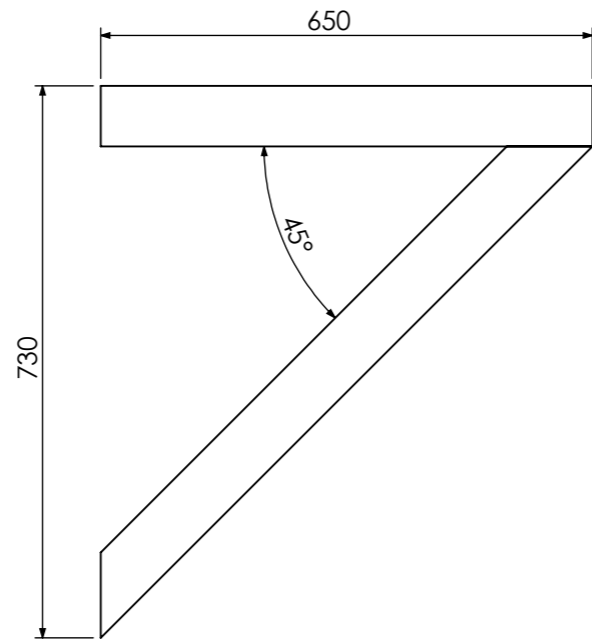
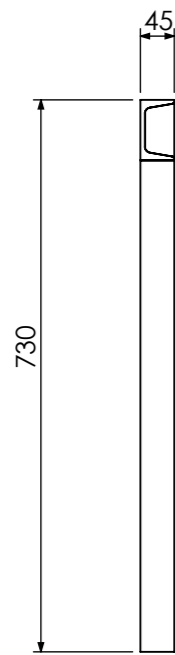

DETAIL AB
SCALE 1 : 10

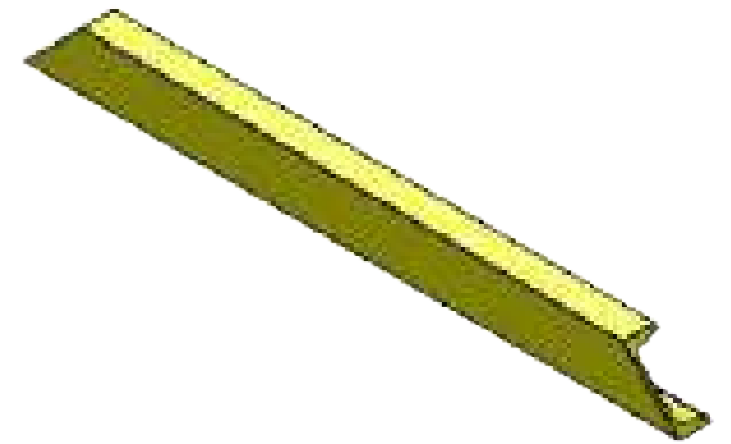

Bag filter ladder structure UPN80.02
BF-01-02-01-02

ITEM NO.	PART NUMBER	PART NAME	WEIGHT(KG)	MATERIAL	QTY.
1	BF-01-02-01-01	Bag filter ladder structure UPN80.01 (L=650mm simple)	5.7	ST37	2
2	BF-01-02-01-02	Bag filter ladder structure UPN80.02	7.4	ST37	2
3	BF-01-01-07-01	Bag filter ladder structure plate.01	0.1	ST37	2

ANG.PROJ.:	گروه صنایع سیمان کرمان (سهامی عام)			
<small>ISO 2768-1 (Tolerance Class m)</small> <small>TELORANCE: ISO 2768-2 (Tolerance Class k)</small> <small>ISO 13920 (Tolerance Class A)</small>				
UNIT: mm, kg	NAME	SIGNATURE	DATE	TITLE:
Document Type: Assem	DRAWN: M.H.Izadi			Bag filter ladder structure part.02 Bag filter ladder structure UPN80.02
QTY.: ***	CHECKED: M.S.Arabnejad			PART NO.: BF-01-02-01 BF-01-02-01-02
	APPROVED: A.Anjomshoa			Document ID: **
Revision:				REF. Document ID:
Revision Date:	Material: --			Record ID:
Classification:	WEIGHT: 26.3 Kg	Scale: 1:20	Sheet: 24 of 61	Size: A3

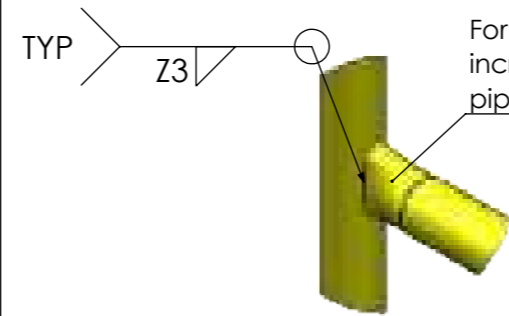
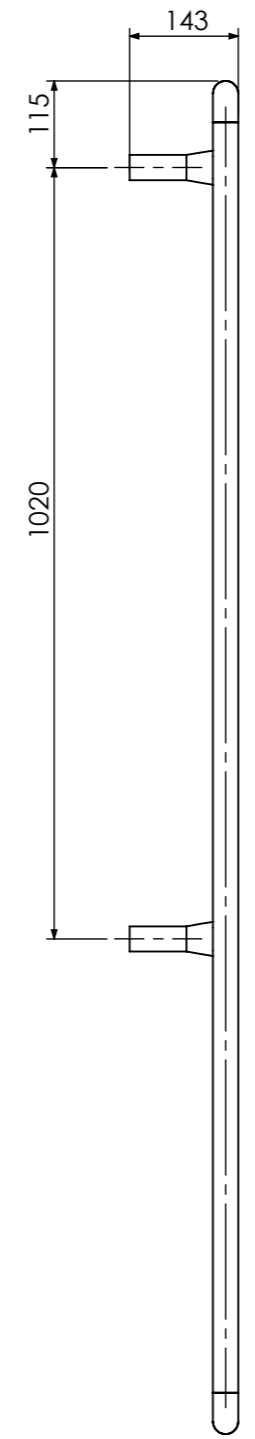
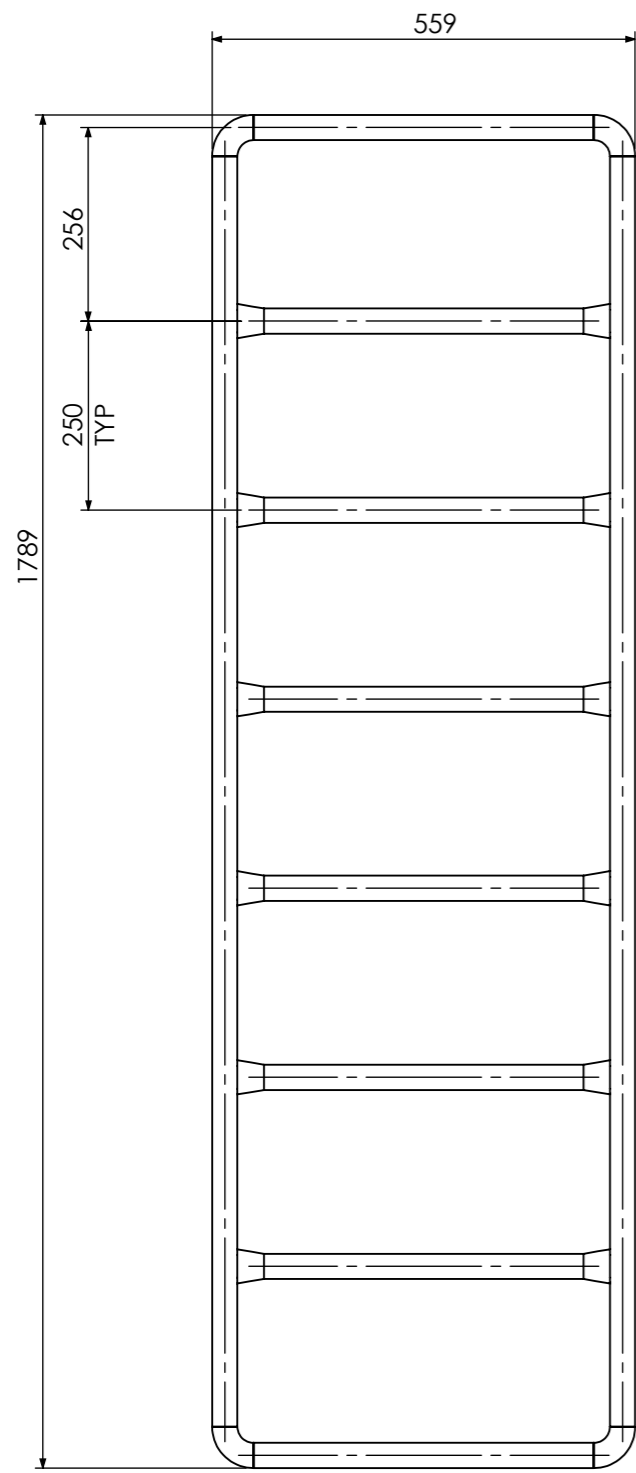

For more reliable welding and increased durability, the end of the pipe is pressed to the size of 2 cm.

DETAIL AC
SCALE 1 : 4

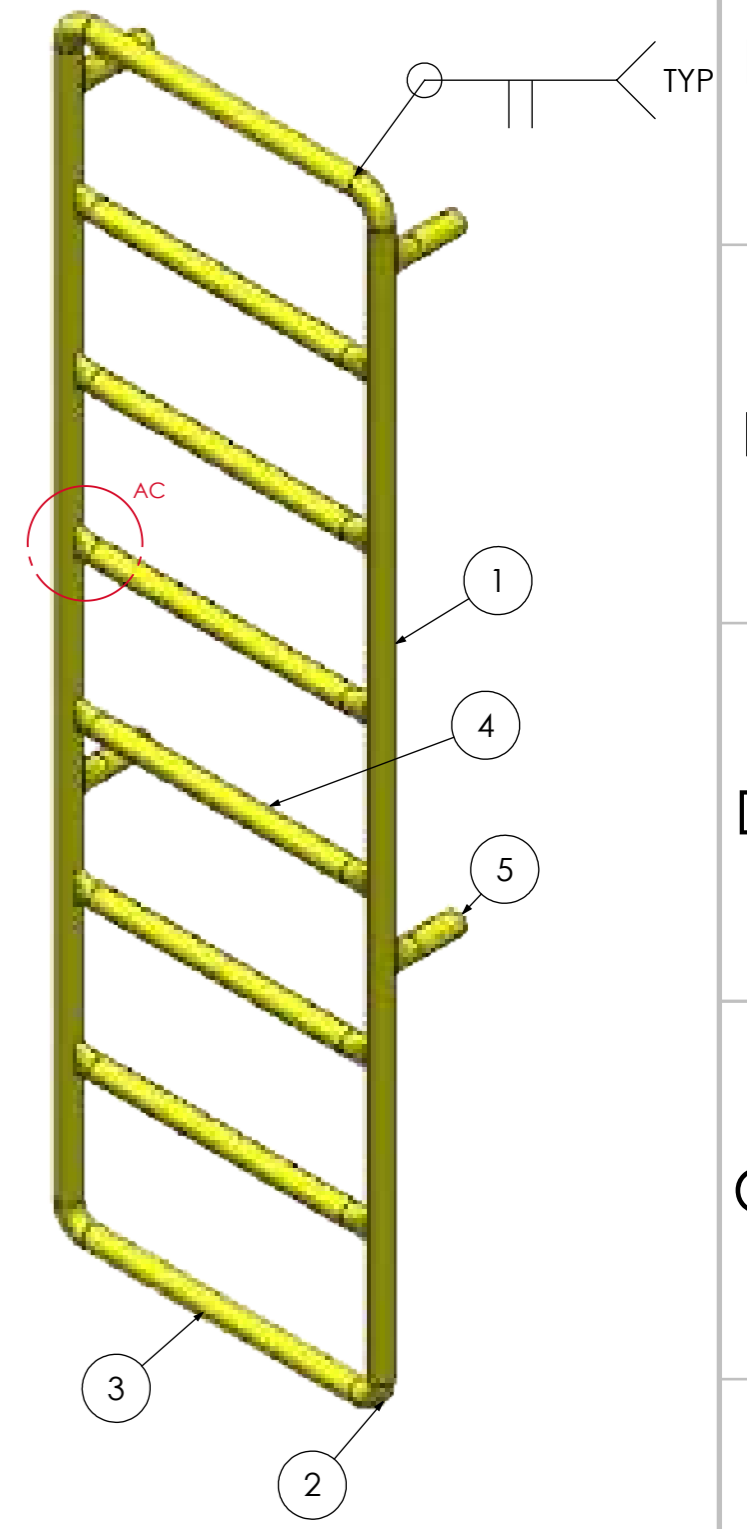

ITEM NO.	PART NUMBER	PART NAME	WEIGHT(KG)	MATERIAL	QTY.
1	BF-01-02-02-01	pipe-ANSI B36.19-1inx 1.65mmL:1680mm- welded Pipe	2.2	ST37	2
2	BF-01-01-02-05-06	1 in welded elbow (90 degree)	0.1	ST37	4
3	BF-01-01-06-02	pipe-ANSI B36.19-1inx 1.65mmL:450mm- welded Pipe	0.6	ST37	2
4	BF-01-01-06-03	pipe-ANSI B36.19-1inx 1.65mmL:492.6mm- welded Pipe	0.6	ST37	6
5	BF-01-01-06-06	pipe-ANSI B36.19-1inx 1.65mmL:110mm- welded Pipe	0.1	ST37	4

ANG.PROJ.:	گروه صنایع سیمان کرمان (سهامی عام)			
TELORANCE: ISO 2768-1 (Tolerance Class m) ISO 2768-2 (Tolerance Class k) ISO 13920 (Tolerance Class A)				
UNIT: mm, kg	SCALE: 1:9	Bag filter ladder Part.02		
Document Type: Assem	NAME: M.H.Izadi	SIGNATURE	DATE	TITLE:
QTY.: ***	CHECKED: M.S.Arabnejad			PART NO.: BF-01-02-02
	APPROVED: A.Anjomshoa			Document ID: **
Revision:				REF. Document ID:
Revision Date:	Material: --			Record ID:
Classification:	WEIGHT: 10.2 Kg	Scale: 1:10	Sheet: 25 of 61	Size: A3

8 7 6 5 4 3 2 1

F
E
D
C
B
A

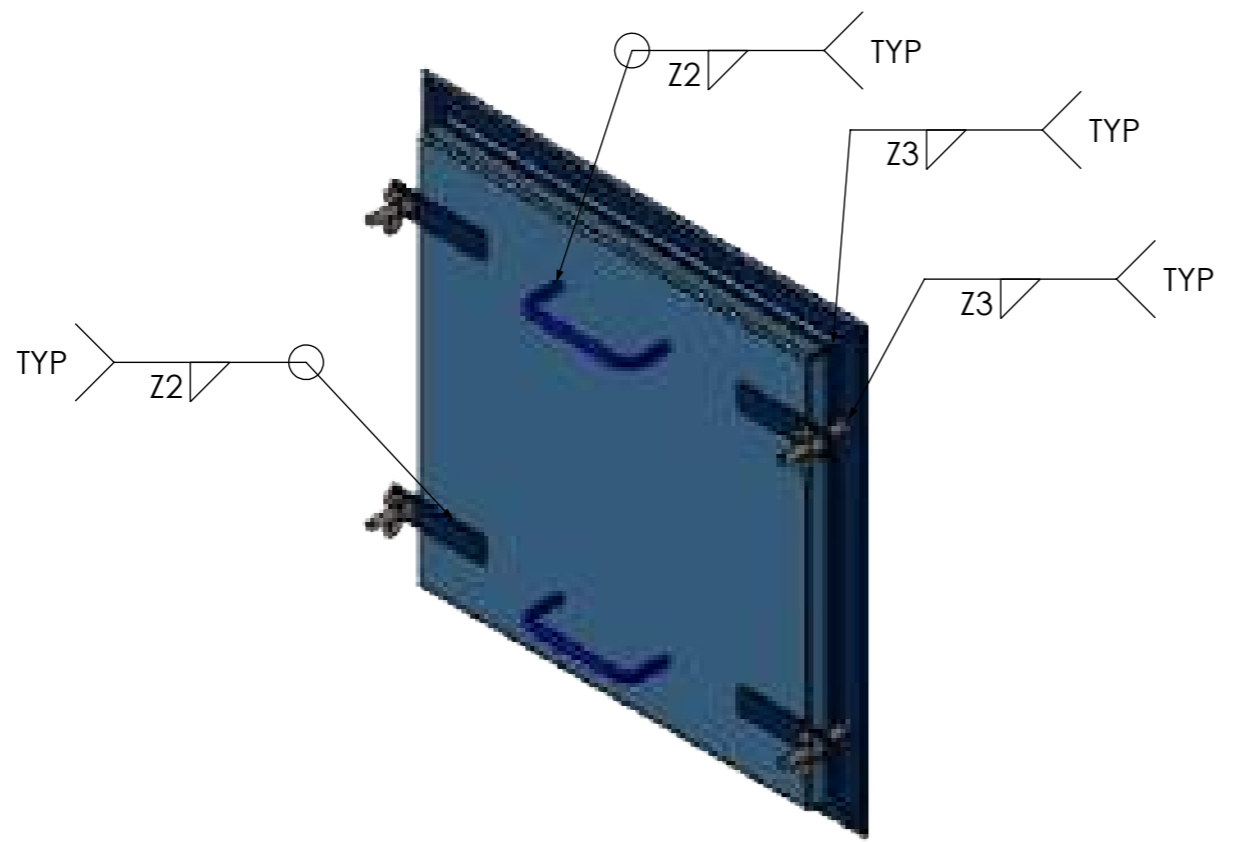
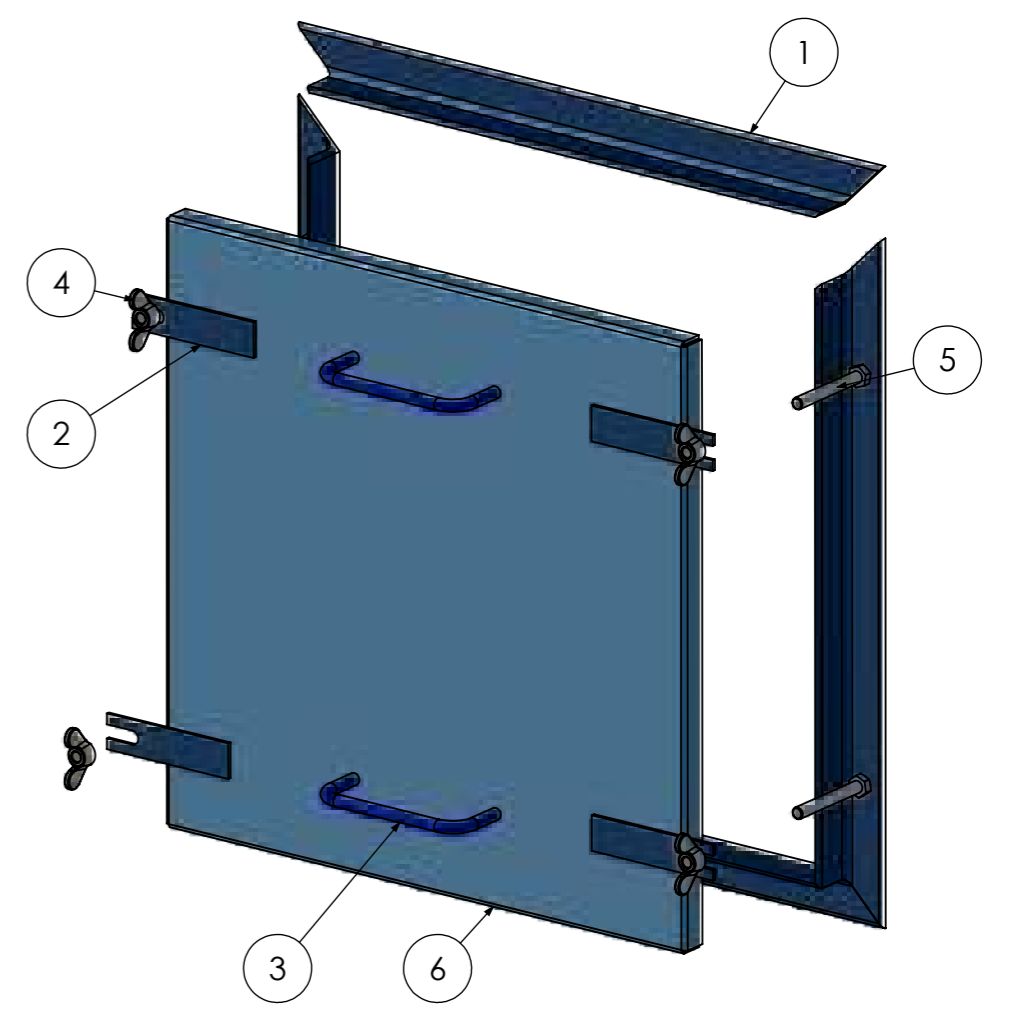
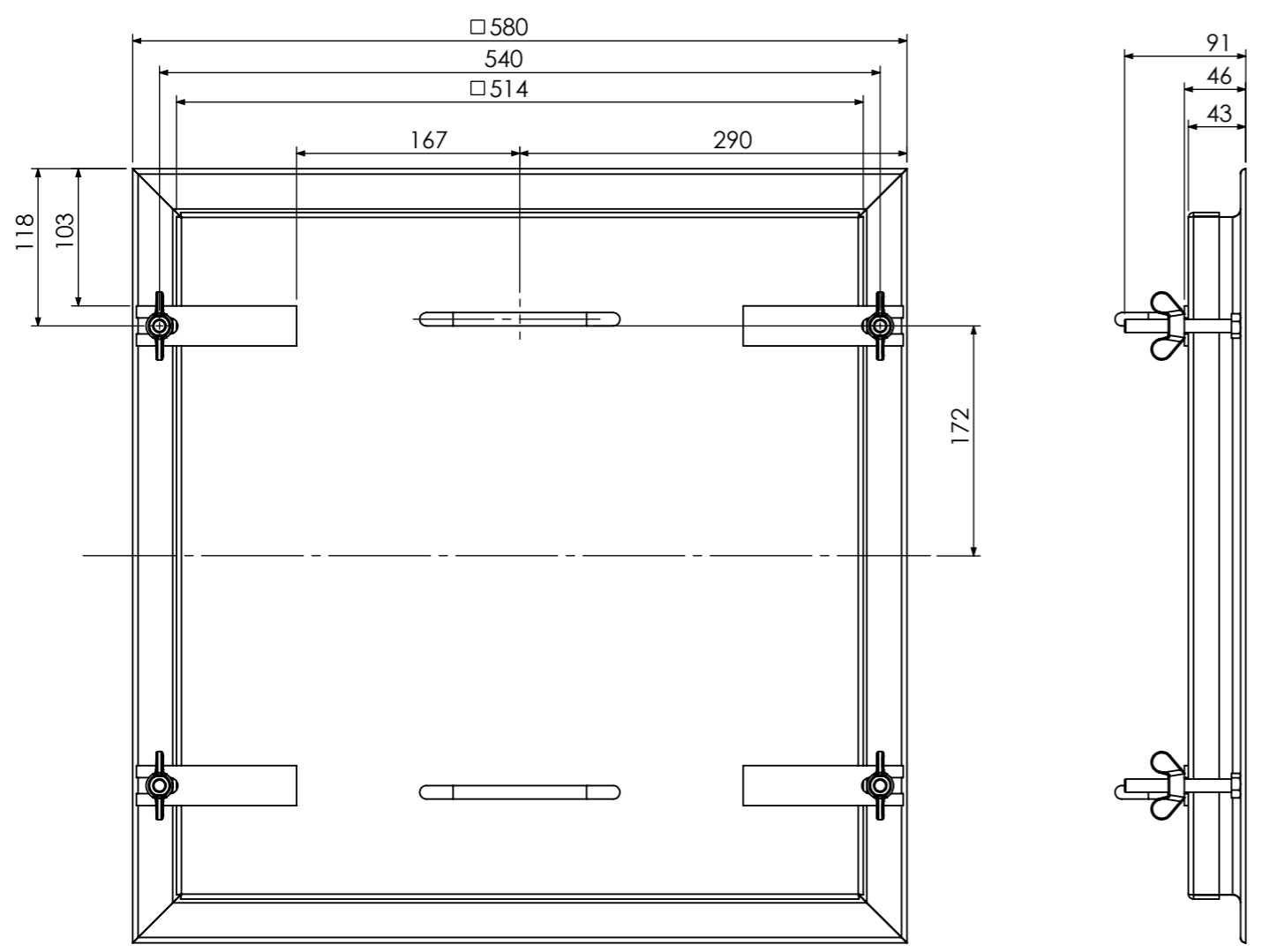

ITEM NO.	PART NUMBER	PART NAME	WEIGHT(KG)	MATERIAL	QTY.
1	BF-01-02-03-01	Bag filter dust hopper window L angel40.40.01	1.2	ST37	4
2	BF-01-02-03-02	Bag filter dust hopper window plate.01	0.1	ST37	4
3	BF-01-02-03-03	Bag filter dust hopper window handle.01	0.1	ST37	2
4	BF-01-02-03-04	Wing Nut Din 315 M10	5.16	--	4
5	BF-01-02-03-05	Bolt-Din933-M10x80-8.8	7.79	--	4
6	BF-01-02-03-06	Bag filter dust hopper window plate.02	7.1	ST37	1

ANG.PROJ.:	گروه صنایع سیمان کرمان (سهامی عام)				
ISO 2768-1 (Tolerance Class m) ISO 2768-2 (Tolerance Class k) ISO 13920 (Tolerance Class A)					
UNIT: mm, kg	Document Type: Assem				
QTY.: ***	DRAWN	M.H.Izadi	SIGNATURE	DATE	TITLE: Bag filter dust hopper window
	CHECKED	M.S.Arabnejad			PART NO.: BF-01-02-03
Revision:	APPROVED	A.Anjomshoa			Document ID: **
Revision Date:	Material: --				REF. Document ID:
Classification:	WEIGHT: 12.7 Kg			Scale: 1:10	Sheet: 26 of 61
					Size: A3

8 7 6 5 4 3 2 1

8 7 6 5 4 3 2 1

F

F

E

E

D

D

C

C

B

B

A

A

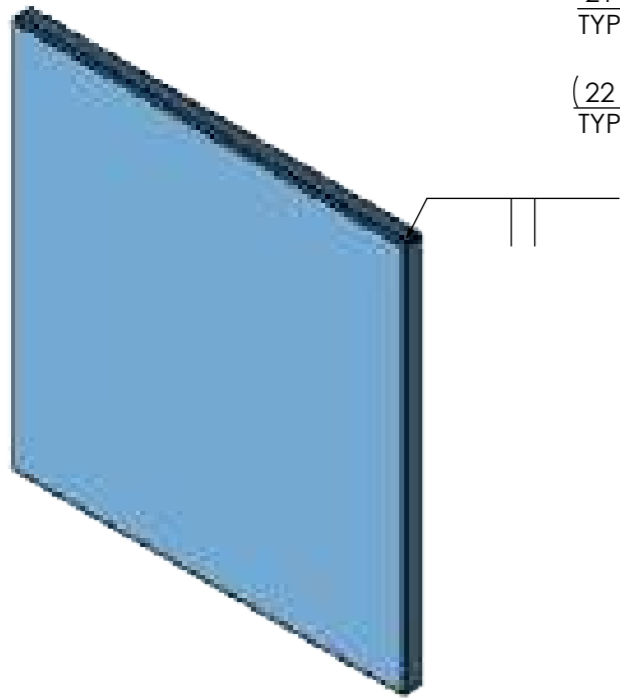
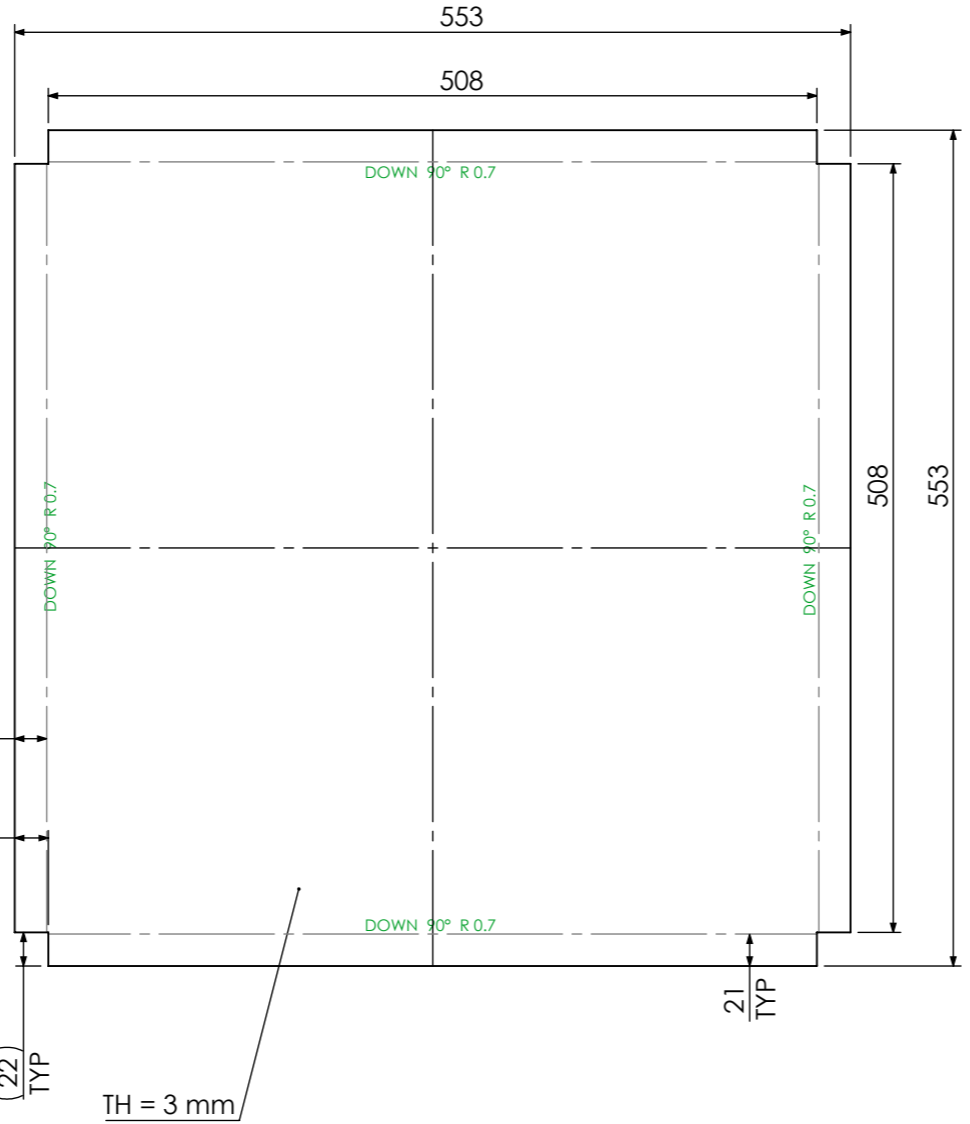
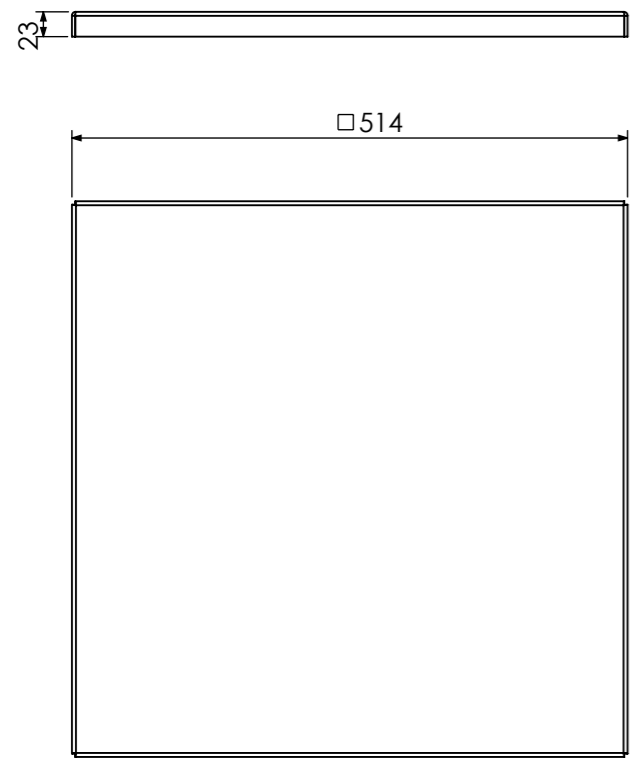

Bag filter dust hopper window plate.02
BF-01-02-03-06

Bag filter dust hopper window L angel40.40.01
BF-01-02-03-01

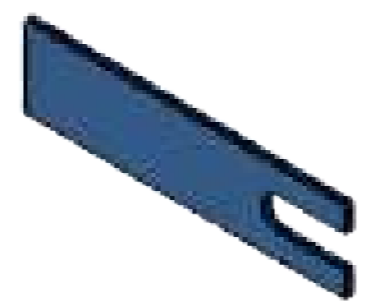
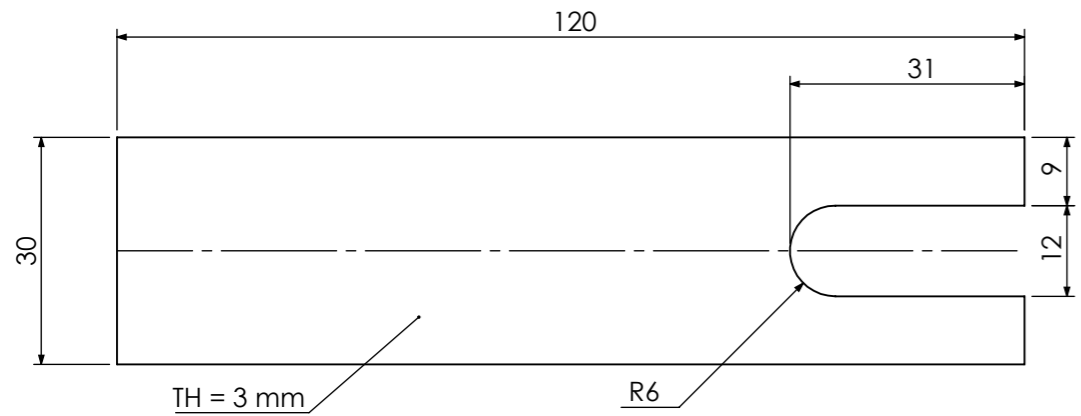

Bag filter dust hopper window plate.01
BF-01-02-03-02

ANG.PROJ.:				
TELORANCE:	ISO 2768-1 (Tolerance Class m) ISO 2768-2 (Tolerance Class k) ISO 13920 (Tolerance Class A)			
UNIT:	mm, kg			
Document Type:	Part	گروه صنایع سیمان کرمان (سهامی عام)		
DRAWN:	M.H.Izadi	SIGNATURE:	DATE:	TITLE: Bag filter dust hopper window L angel40.40.01 Bag filter dust hopper window plate(01-02)
CHECKED:	M.S.Arabnejad	PART NO.: BF-01-02-03-(01-02-06)		
APPROVED:	A.Anjomshoa	Document ID: **		
Revision:				REF. Document ID:
Revision Date:	Material: --			Record ID:
Classification:	WEIGHT: 1.2 Kg	Scale: 1:10	Sheet: 27 of 61	Size: A3

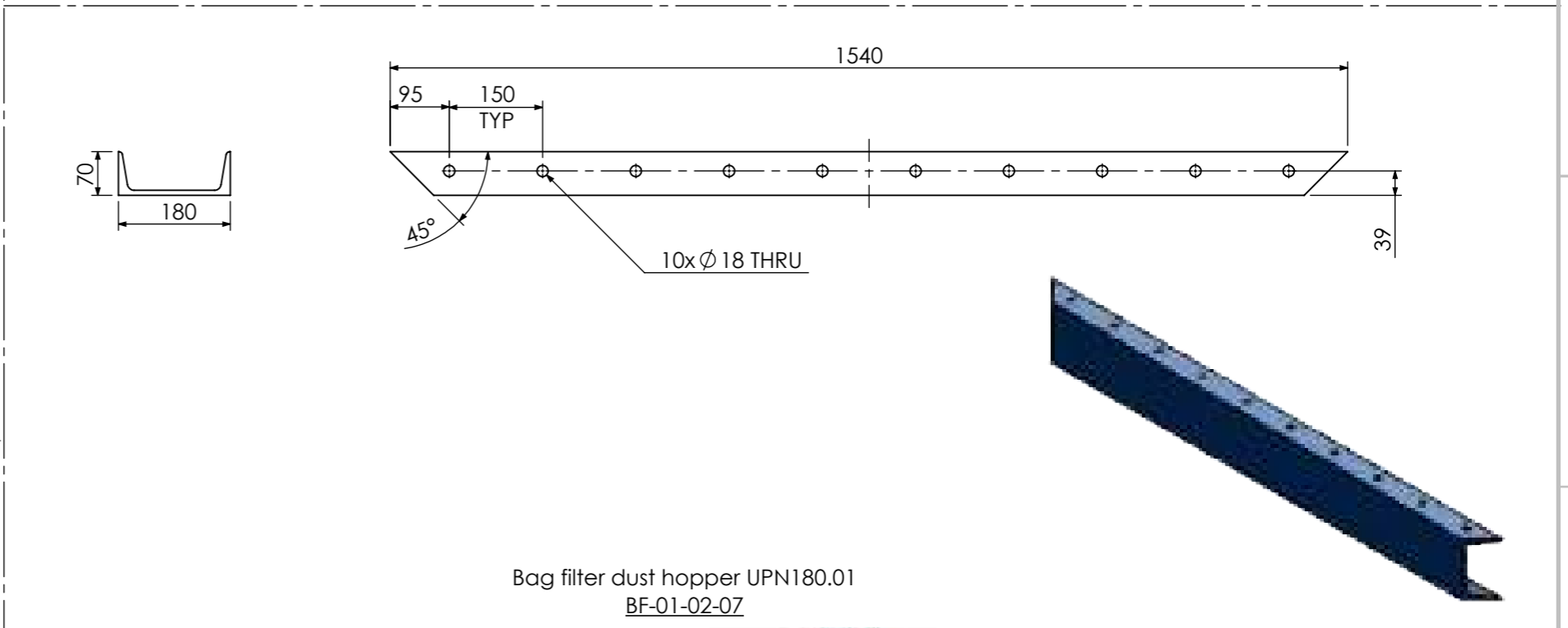
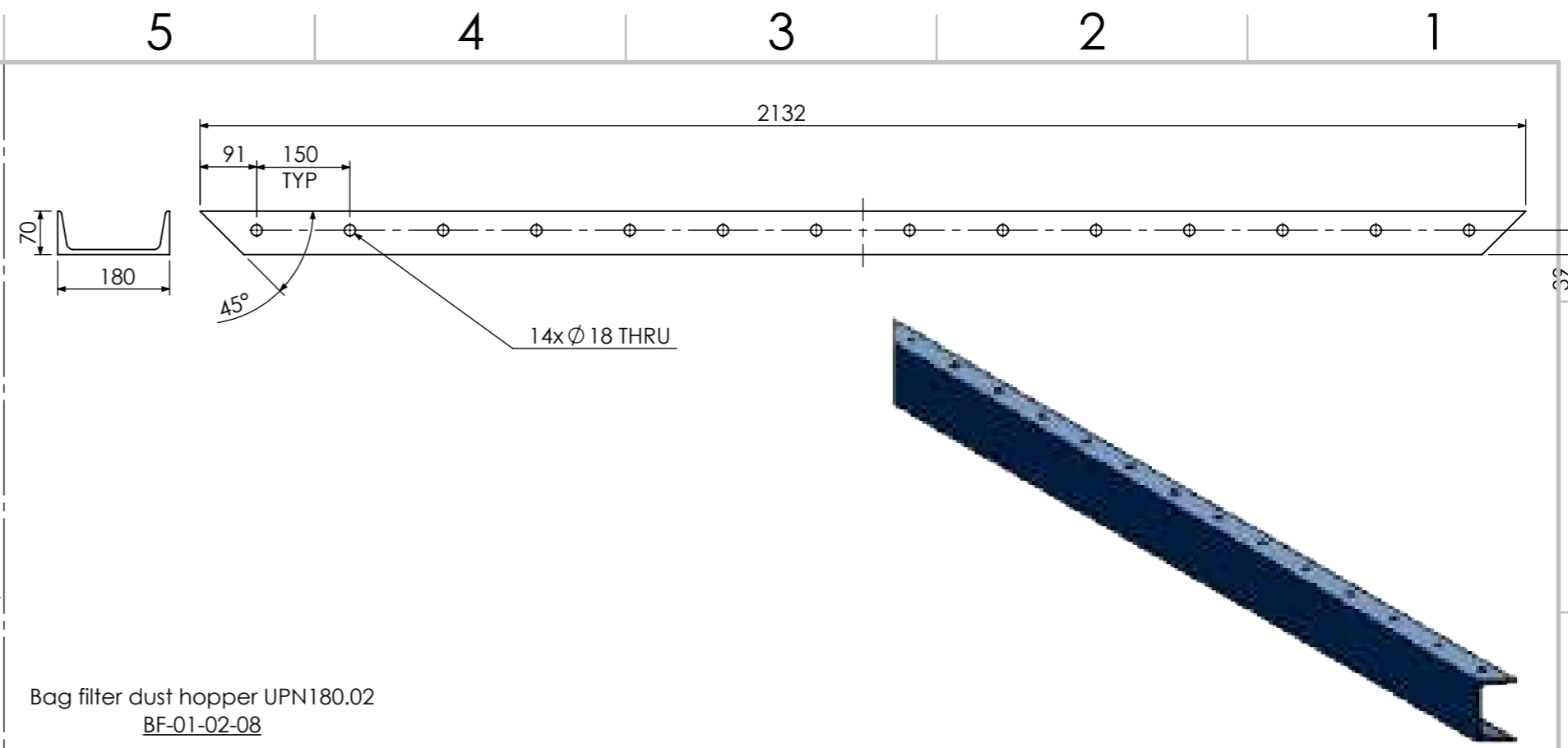
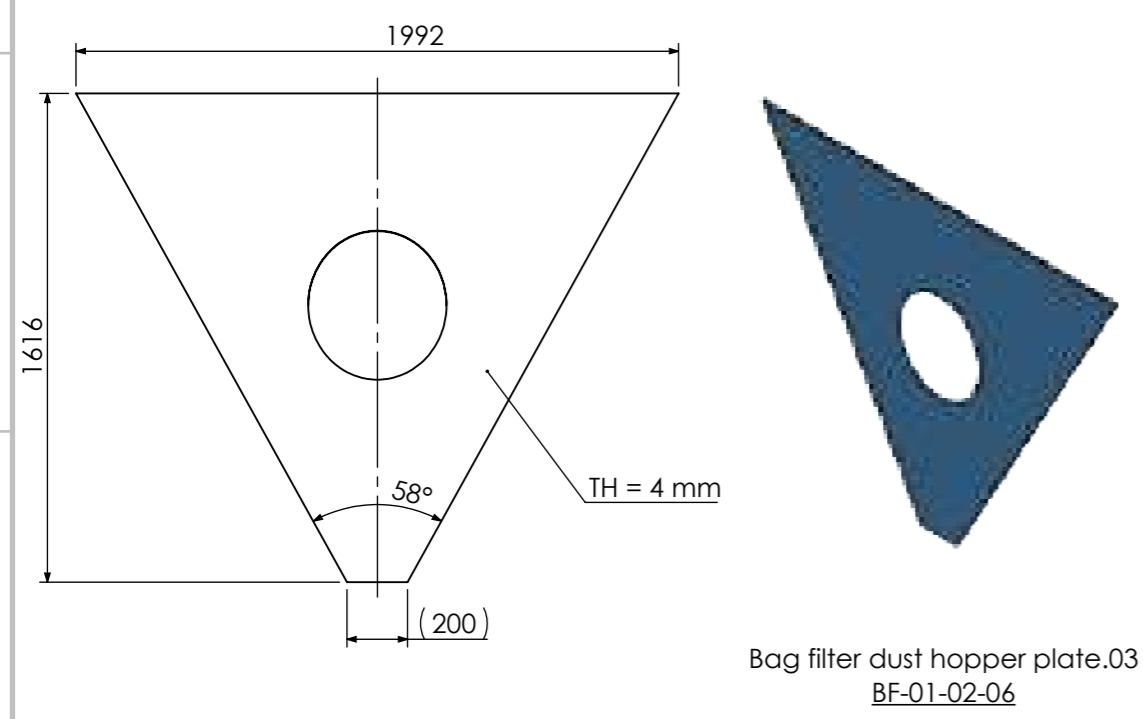
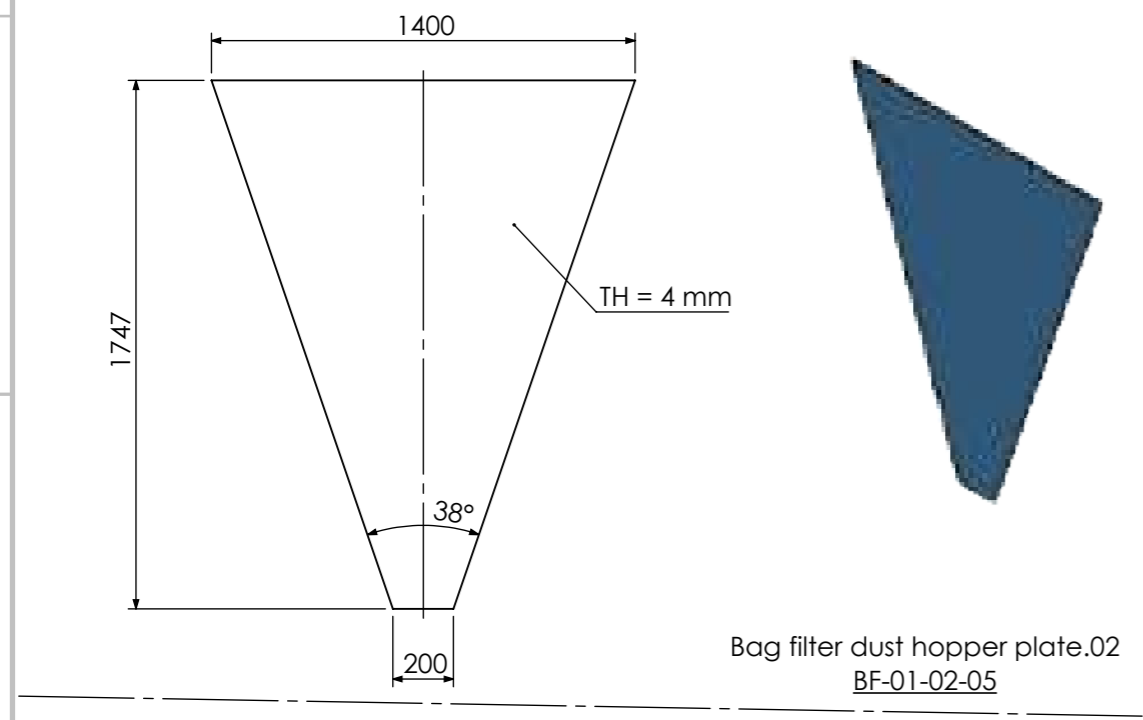
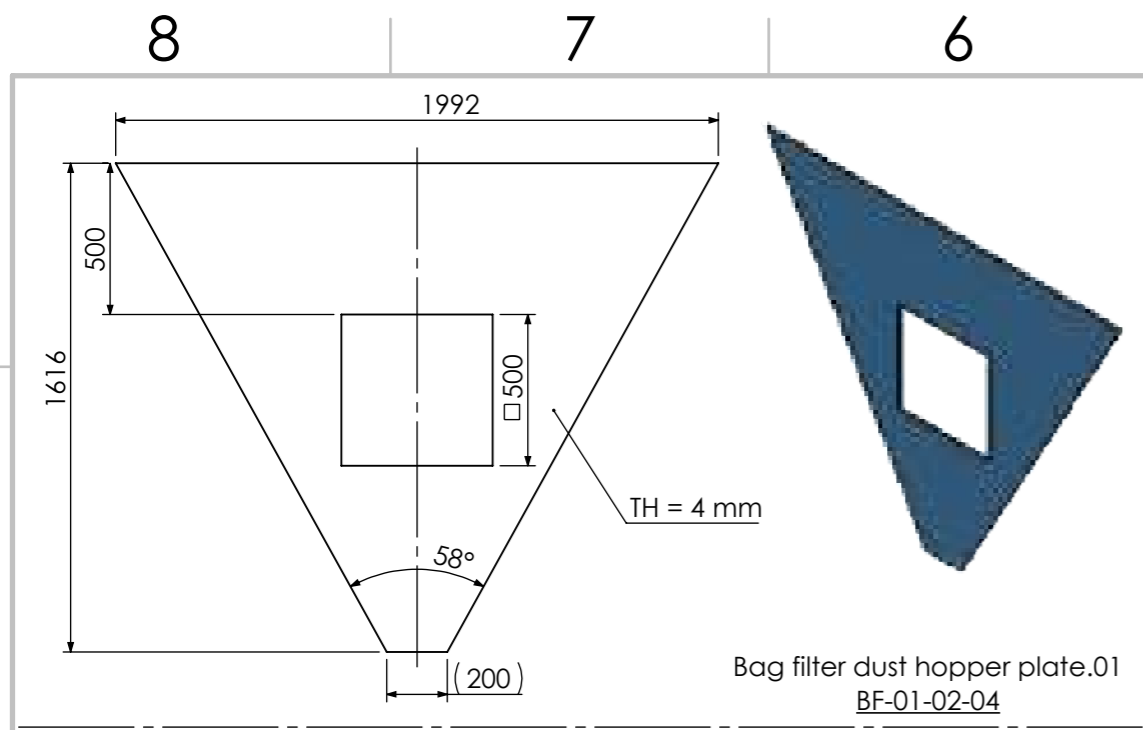

ANG.PROJ.:		گروه صنایع سیمان کرمان (سهامی عام)			
TELORANCE:	ISO 2768-1 (Tolerance Class m) ISO 2768-2 (Tolerance Class k) ISO 13920 (Tolerance Class A)				
UNIT:	mm, kg				
Document Type:	Part	NAME	SIGNATURE	DATE	TITLE:
		DRAWN	M.H.Izadi		Bag filter dust hopper plate(01-02-03) Bag filter dust hopper UPN180(01-02)
QTY.:	***	CHECKED	M.S.Arabnejad		PART NO.: BF-01-02-(04-05-06-07-08)
		APPROVED	A.Anjomshoa		Document ID: **
Revision:					REF. Document ID:
Revision Date:		Material:	--		Record ID:
Classification:		WEIGHT:	47.7 Kg	Scale:	1:10
				Sheet:	28 of 61
				Size:	A3

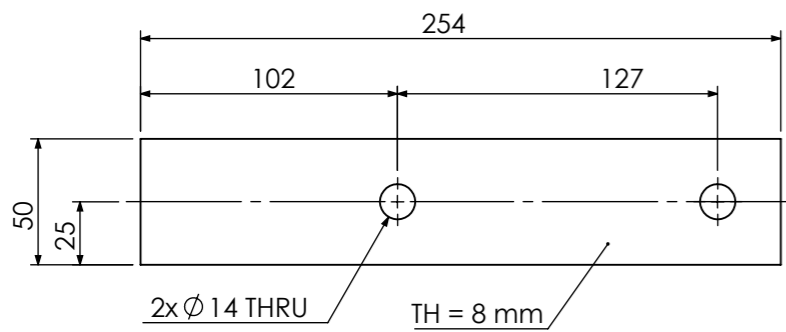

Bag filter dust hopper plate.05
BF-01-02-10

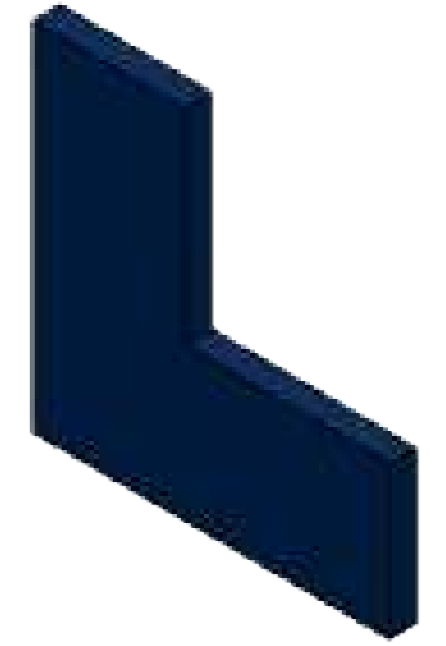
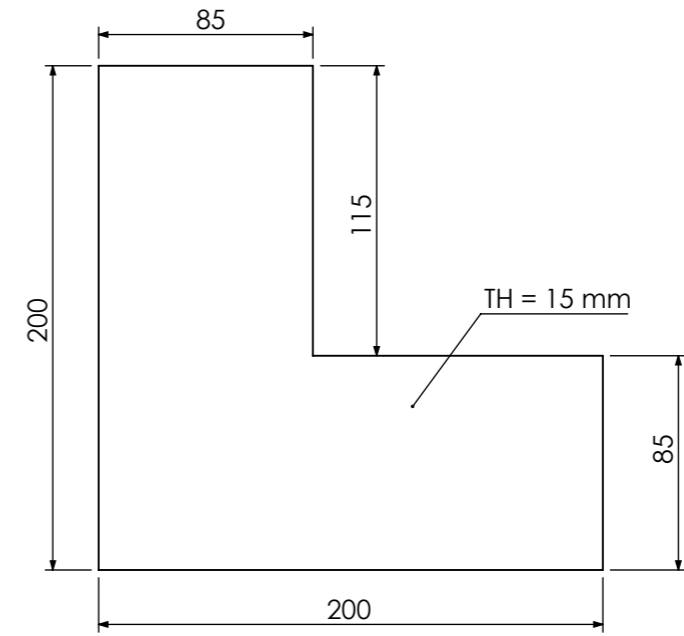

Bag filter dust hopper plate.06
BF-01-02-12

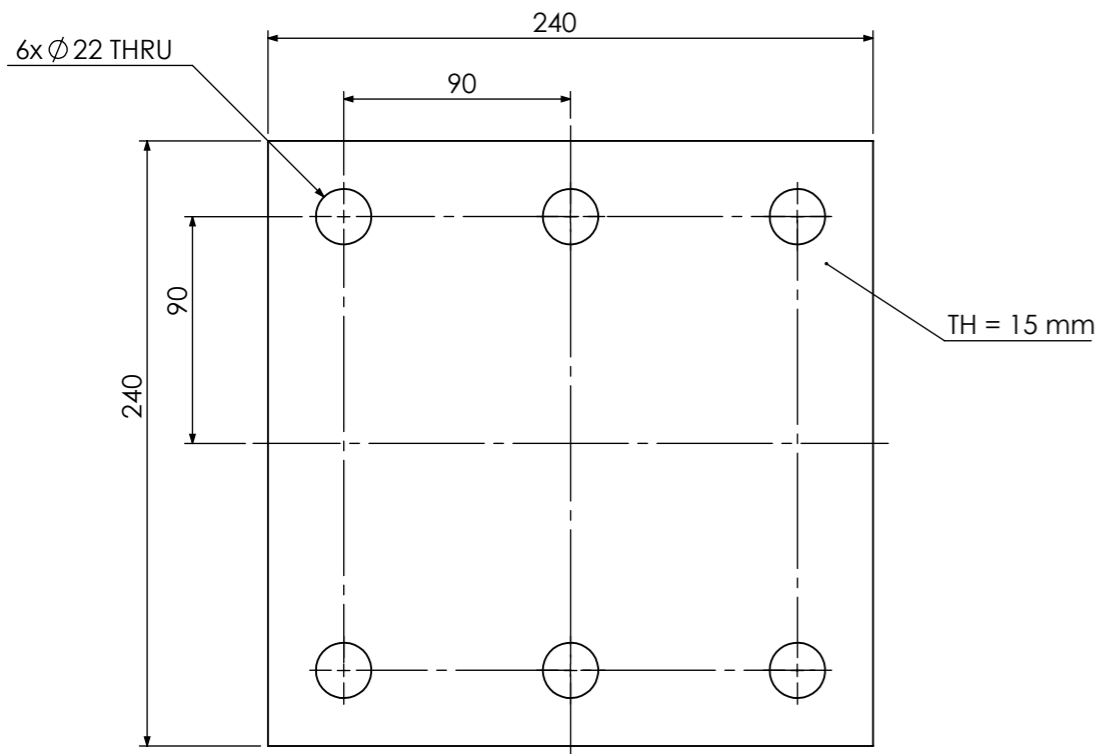

Bag filter dust hopper plate.07
BF-01-02-13

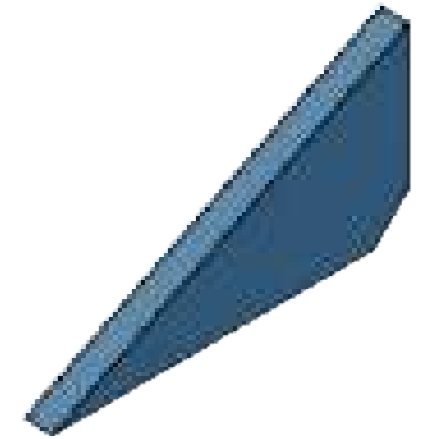
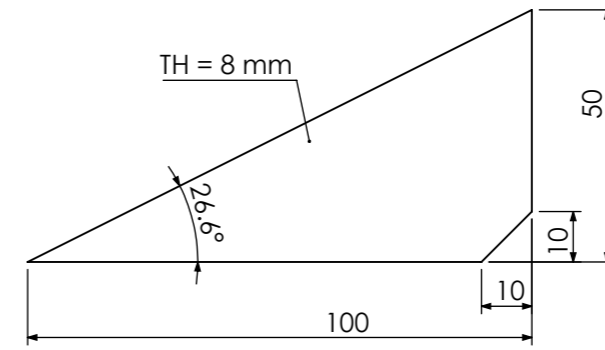

Bag filter dust hopper plate.09
BF-01-02-15

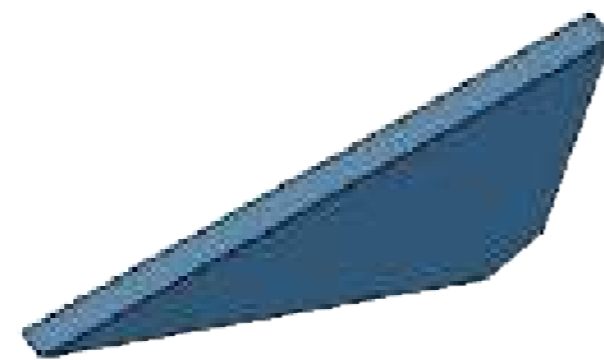
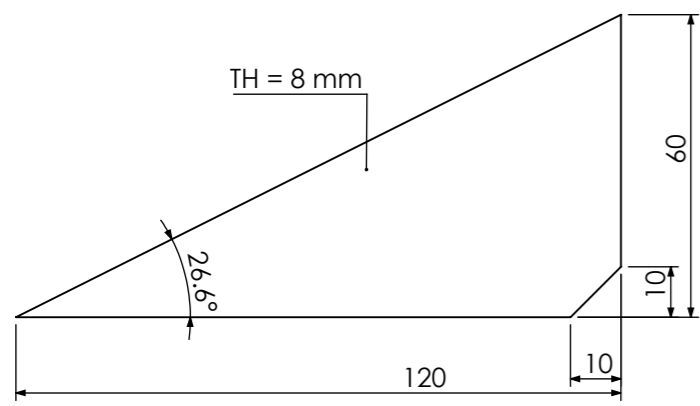

Bag filter dust hopper plate.08
BF-01-02-14

ANG.PROJ.:		گروه صنایع سیمان کرمان (سهامی عام)			
TELORANCE:	ISO 2768-1 (Tolerance Class m) ISO 2768-2 (Tolerance Class k) ISO 13920 (Tolerance Class A)				
UNIT:	mm, kg				
Document Type:	Part	NAME	SIGNATURE	DATE	TITLE:
		DRAWN	M.H.Izadi		Bag filter dust hopper plate(05-06-07-08-09)
QTY.:	***	CHECKED	M.S.Arabnejad		PART NO.: BF-01-02-(10-12-13-14-15)
		APPROVED	A.Anjomshoa		Document ID: **
Revision:					REF. Document ID:
Revision Date:		Material: --			Record ID:
Classification:		WEIGHT:	0.8 Kg	Scale: 1:2	Sheet: 29 of 61
					Size: A3

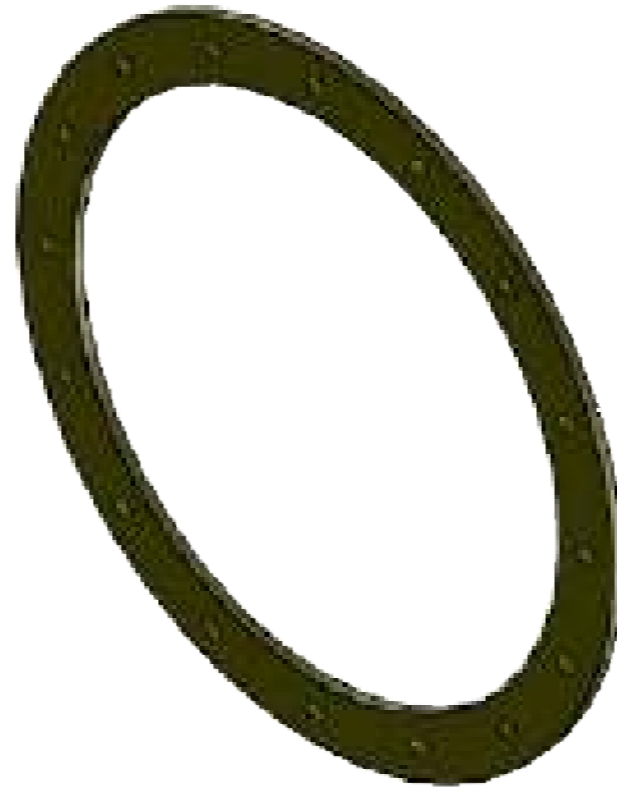
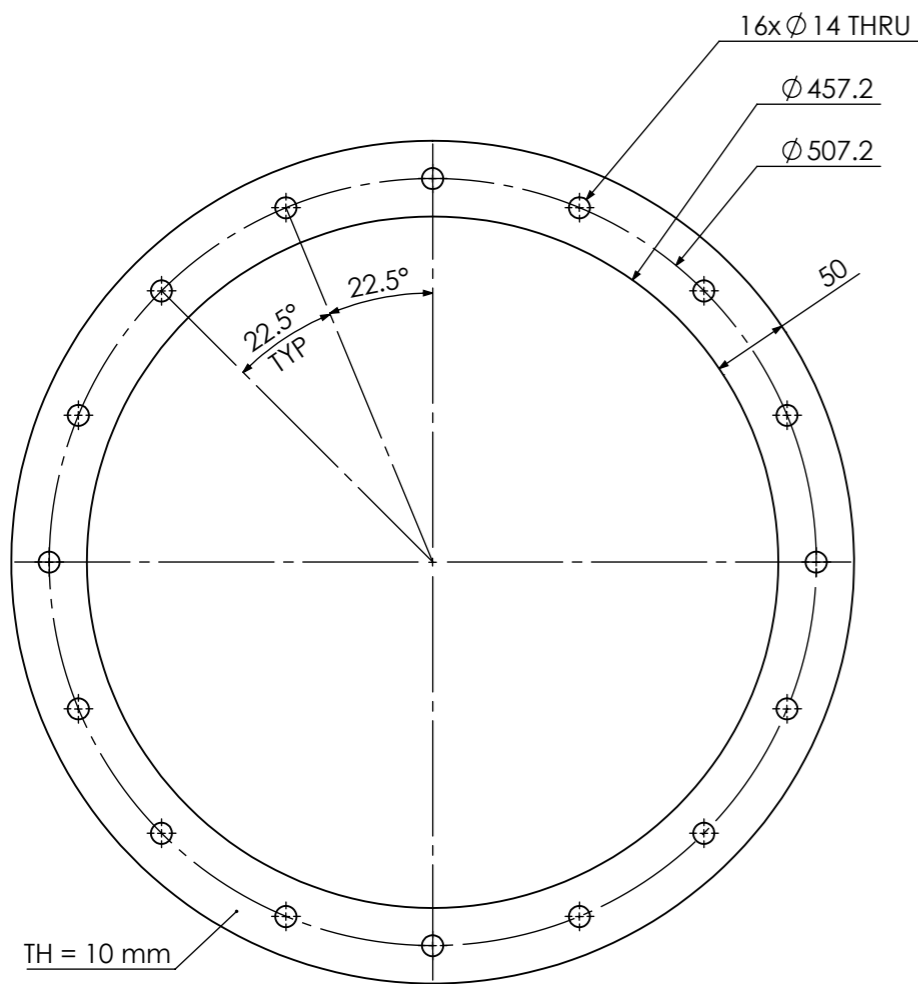

Bag filter dust hopper plate.11
 BF-01-02-17

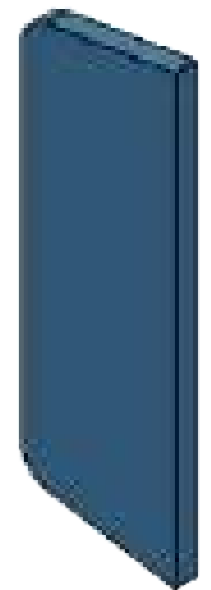
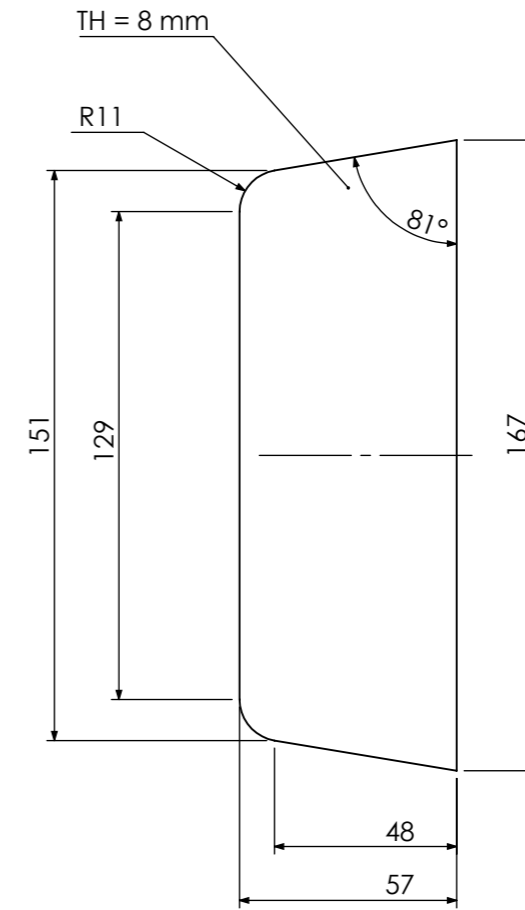

Bag filter dust hopper plate.10
 BF-01-02-16

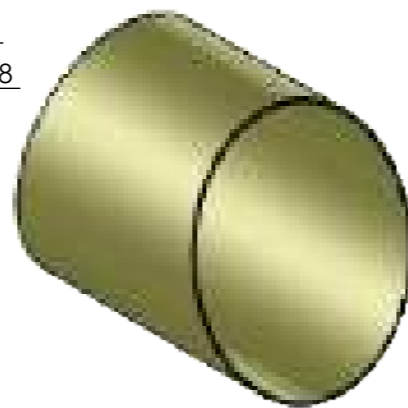
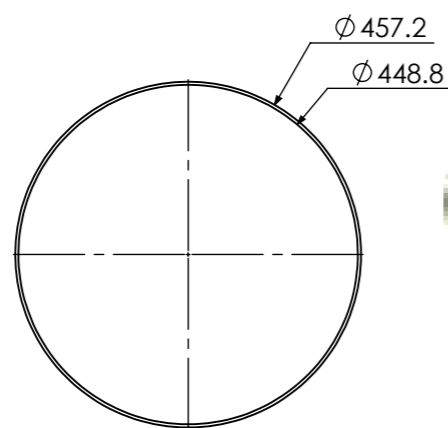
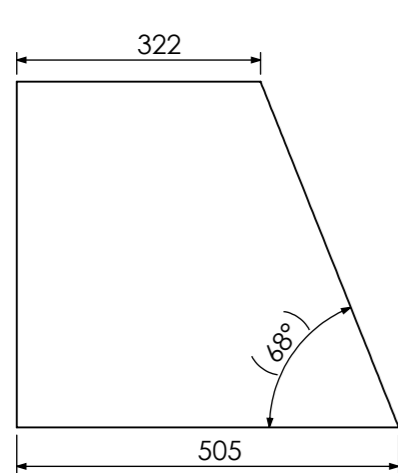

Bag filter dust hopper pipe 18 in.01
 BF-01-02-18

ANG.PROJ.:				گروه صنایع سیمان کرمان		
ISO 2768-1 (Tolerance Class m) ISO 2768-2 (Tolerance Class k) ISO 13920 (Tolerance Class A)	(سهامی عام)					
UNIT: mm, kg	NAME		SIGNATURE	DATE	TITLE:	
Document Type: Part	DRAWN	M.H.Izadi			Bag filter dust hopper pipe 18 in.01 Bag filter dust hopper plate(10-11)	
QTY: ***	CHECKED	M.S.Arabnejad			PART NO.: BF-01-02-(16-17-18)	
	APPROVED	A.Anjomshoa			Document ID: **	
Revision:					REF. Document ID:	
Revision Date:	Material: --				Record ID:	
Classification:	WEIGHT: 0.6 Kg		Scale: 1:2		Sheet: 30 of 61	Size: A3

8 7 6 5 4 3 2 1

F F

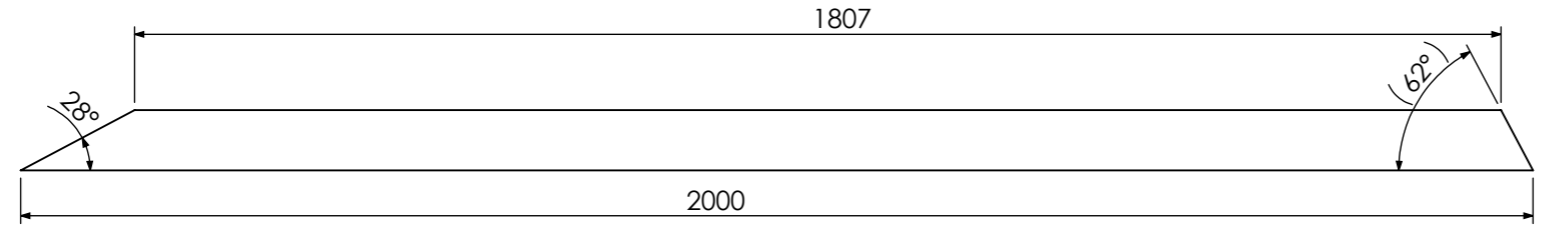
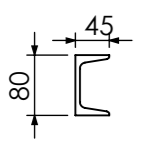

Bag filter dust hopper UPN80.01
BF-01-02-20

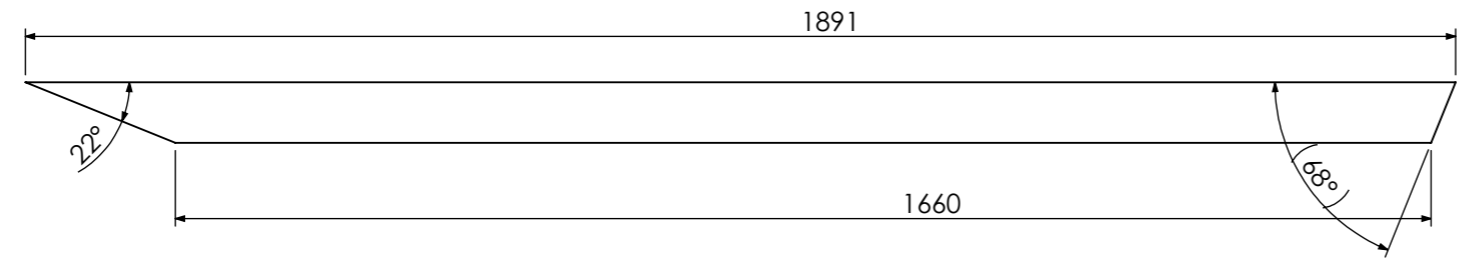
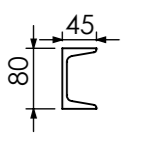

Bag filter dust hopper UPN80.02
BF-01-02-21

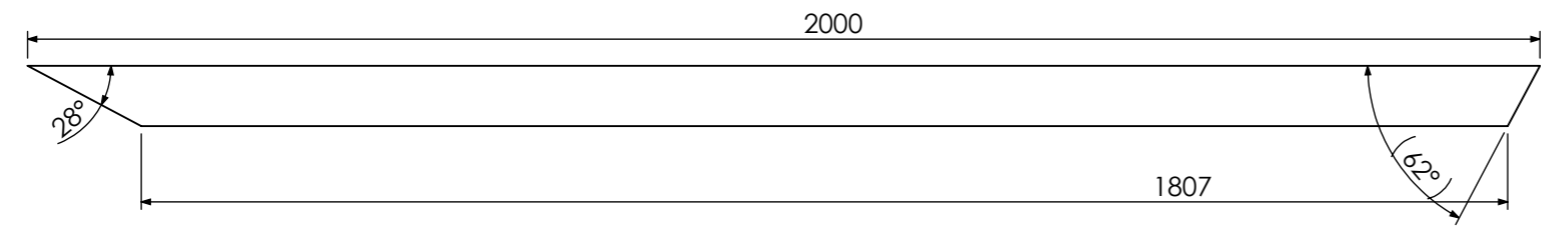
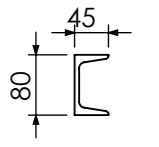

Bag filter dust hopper UPN80.03
BF-01-02-22

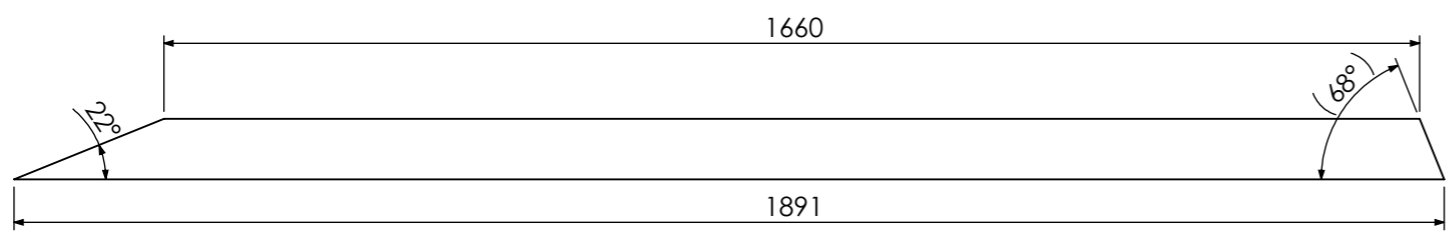
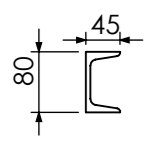

Bag filter dust hopper UPN80.04
BF-01-02-23

ANG.PROJ.:	گروه صنایع سیمان کرمان (سهامی عام)			
<small>ISO 2768-1 (Tolerance Class m)</small> <small>ISO 2768-2 (Tolerance Class k)</small> <small>ISO 13920 (Tolerance Class A)</small>				
UNIT: mm, kg				
Document Type: Part	NAME	SIGNATURE	DATE	TITLE:
	DRAWN M.H.Izadi			Bag filter dust hopper UPN80(01-02-03-04)
QTY.: ***	CHECKED M.S.Arabnejad			PART NO.: BF-01-02-(20-21-22-23)
	APPROVED A.Anjomshoa			Document ID: **
Revision:				REF. Document ID:
Revision Date:	Material: --			Record ID:
Classification:	WEIGHT: 16.7 Kg	Scale: 1:20		Sheet: 31 of 61
				Size: A3

A A

8 7 6 5 4 3 2 1

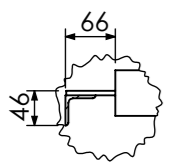
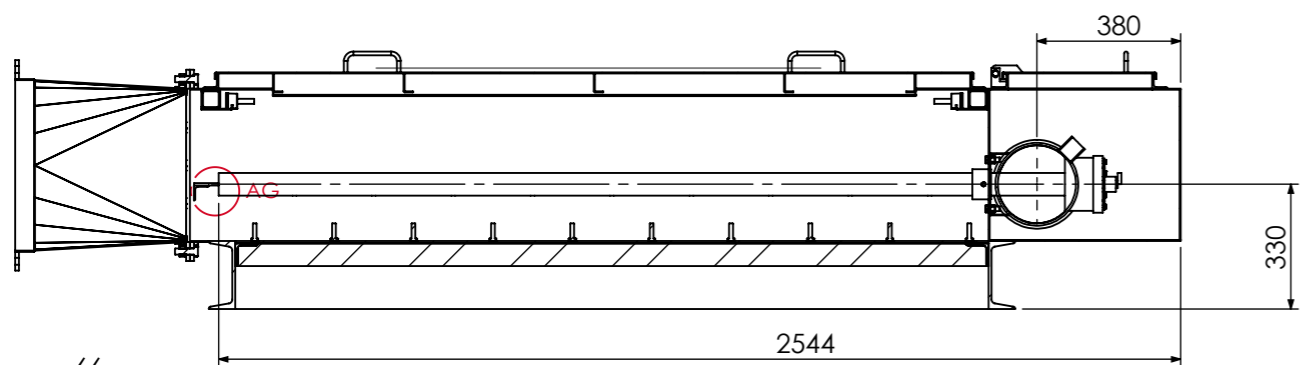
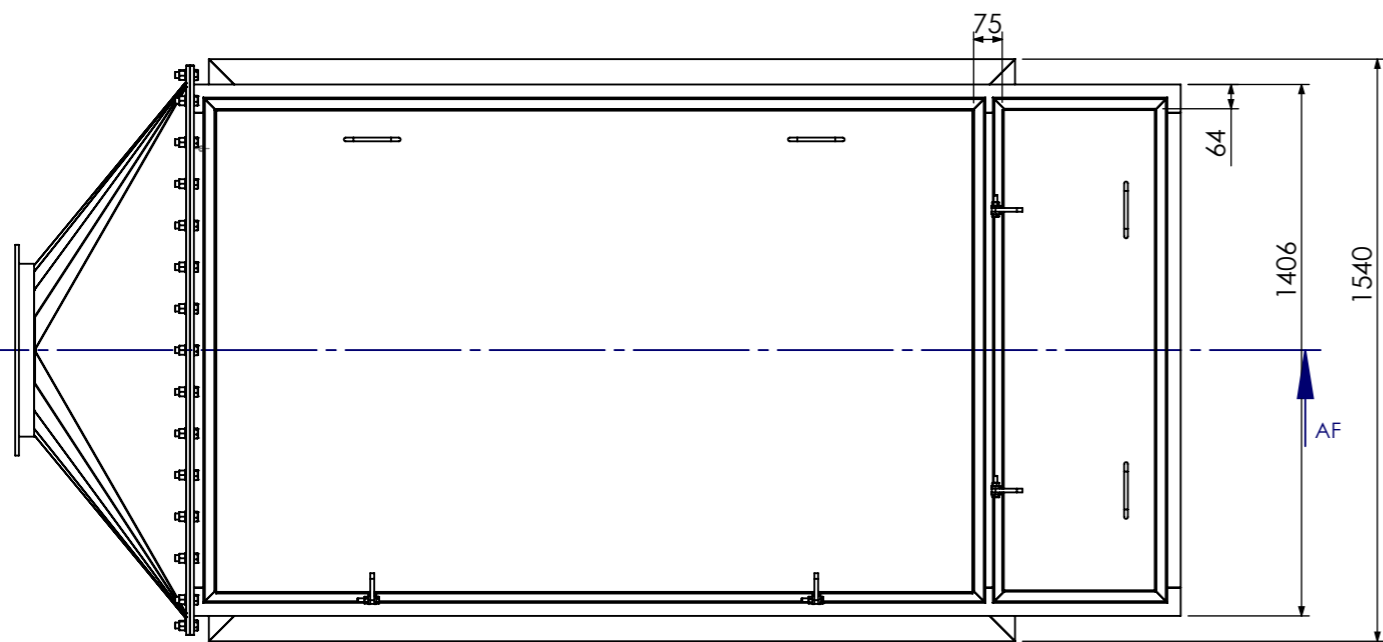
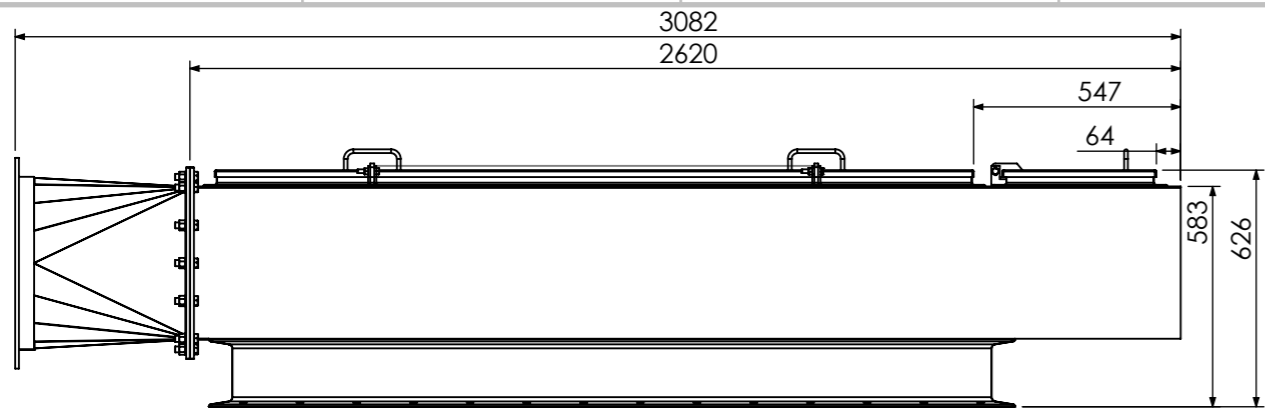

SECTION AF-AF
SCALE 1 : 20

DETAIL AG
SCALE 1 : 10

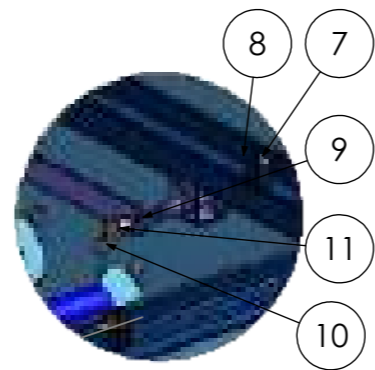
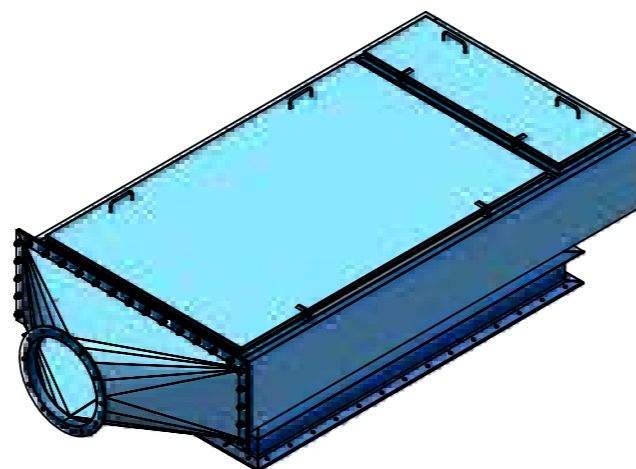
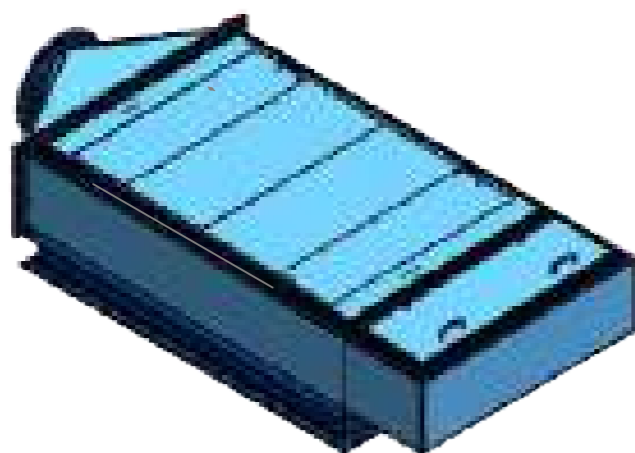

DETAIL AD
SCALE 1 : 10

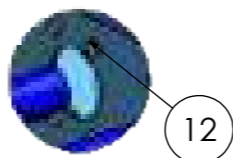

DETAIL AE
SCALE 1 : 10

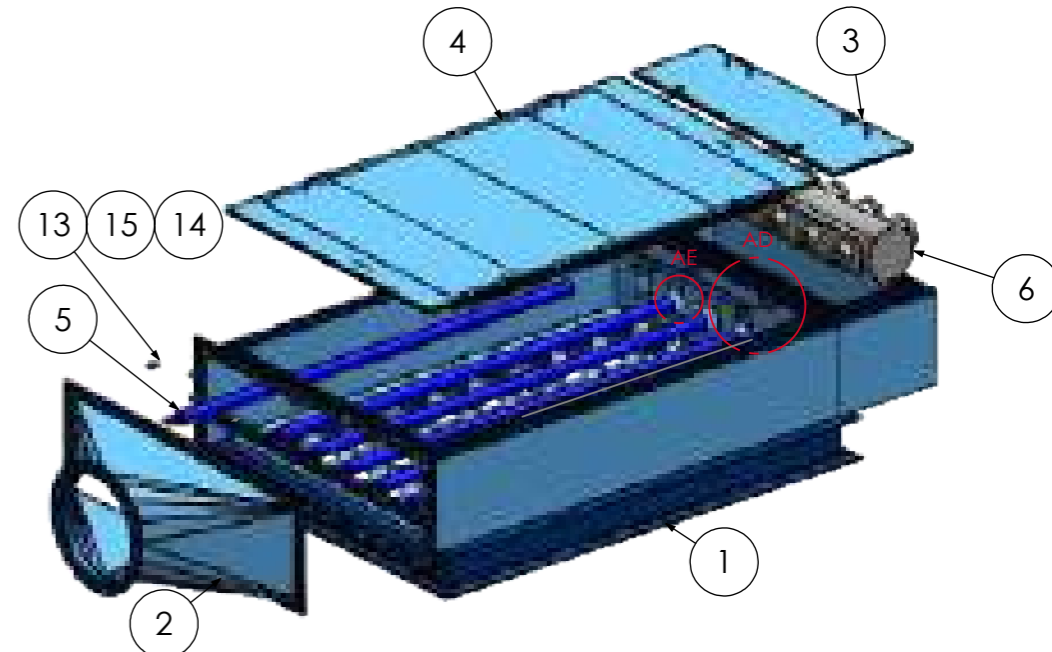

ITEM NO.	PART NUMBER	PART NAME	WEIGHT(KG)	MATERIAL	QTY.
1	BF-01-03-01	Bag filter clean gas chamber body	435.1	--	1
2	BF-01-03-02	Bag filter clean gas outlet	50.3	--	1
3	BF-01-03-03	Bag filter clean gas chamber window.01	13.8	--	1
4	BF-01-03-04	Bag filter clean gas chamber window.02	80.0	--	1
5	BF-01-03-05	Bag filter pressurized air distribution pipe.01	11.0	--	6
6	BF-01-03-06	Bag filter pressurized air tank.01	90.7	--	1
7	BF-01-03-07	Bolt-Din933-M10x50-8.8	5.43	--	4
8	BF-01-17-00	Nut-Din934-M10	0.0	--	4
9	BF-01-03-08	Bag filter clean gas chamber window holder.01	1.1	--	2
10	BF-01-03-09	Split pin ISO 1234 - 4x32 - ST	0.0	--	2
11	BF-01-03-10	Castle Nut-Din979-M16	0.1	--	2
12	BF-01-03-11	Bolt-Din933-M12x30-8.8	0.0	--	24
13	BF-01-11-00	Bolt-Din933-M16x50-8.8	0.0	--	36
14	BF-01-12-00	Nut-Din934-M16	5.42	--	36
15	BF-01-16-00	Spring washer-Din128-A16-FST	1.03	--	36

ANG.PROJ.:				
TELERANCE:	ISO 2768-1 (Tolerance Class m) ISO 2768-2 (Tolerance Class k) ISO 13920 (Tolerance Class A)			
UNIT: mm, kg	(سهامی عام)			
Document Type: Assem	NAME	SIGNATURE	DATE	TITLE: Bag filter clean gas chamber
QTY.: ***	DRAWN: M.H.Izadi	CHECKED: M.S.Arabnejad	APPROVED: A.Anjomshoa	PART NO.: BF-01-03-00
Revision:	Material: --			REF. Document ID:
Revision Date:	WEIGHT: 739.5 Kg			Record ID:
Classification:	Scale: 1:50			Sheet: 32 of 61
	Size: A3			

8 7 6 5 4 3 2 1

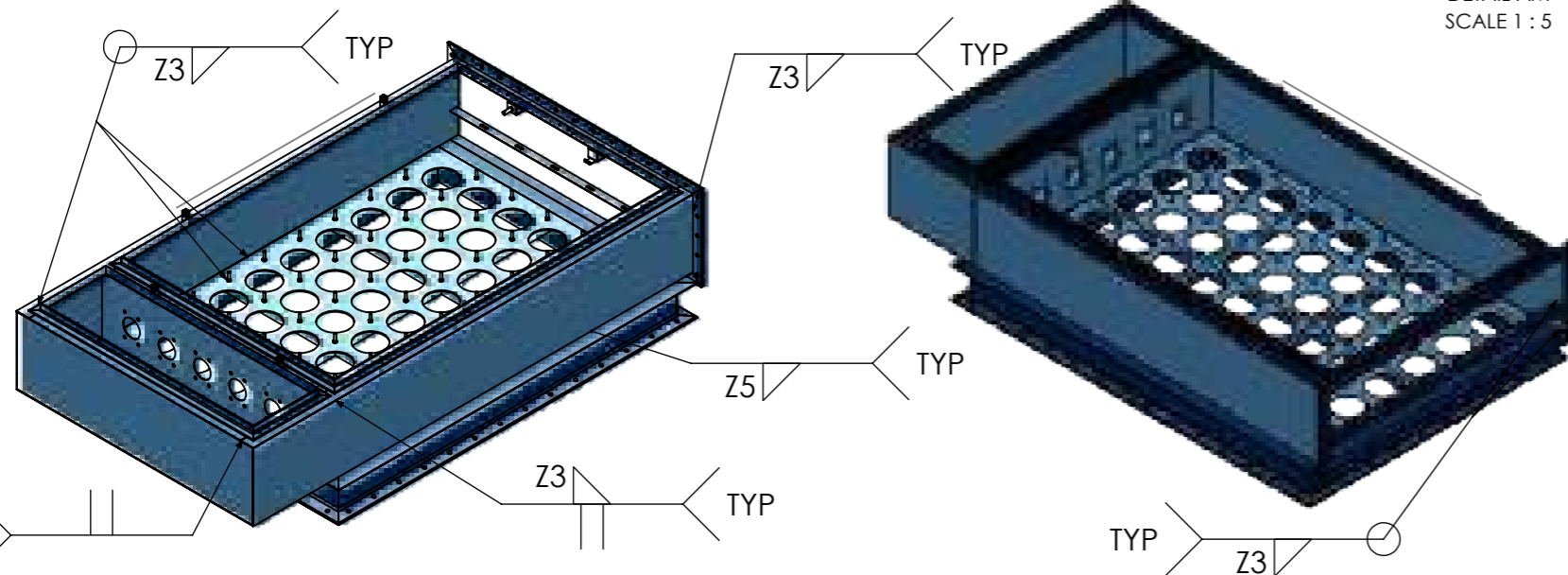
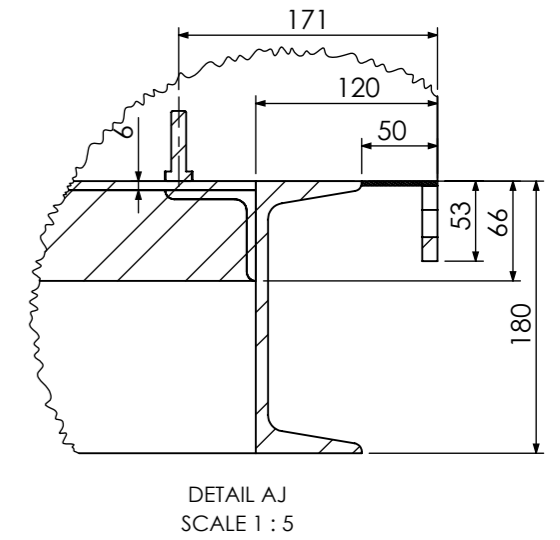
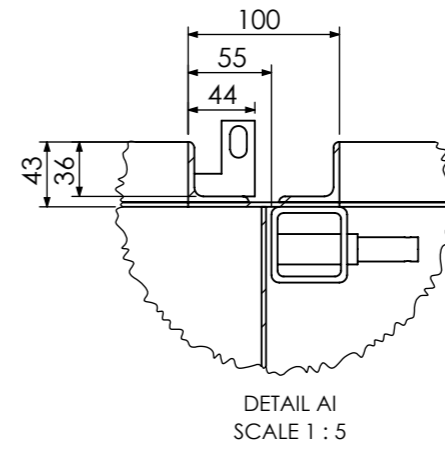
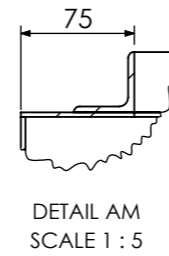
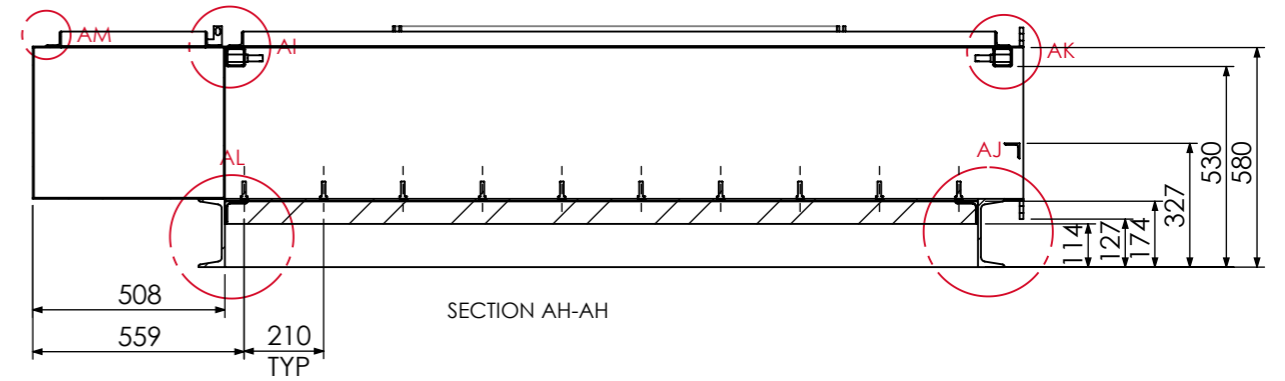
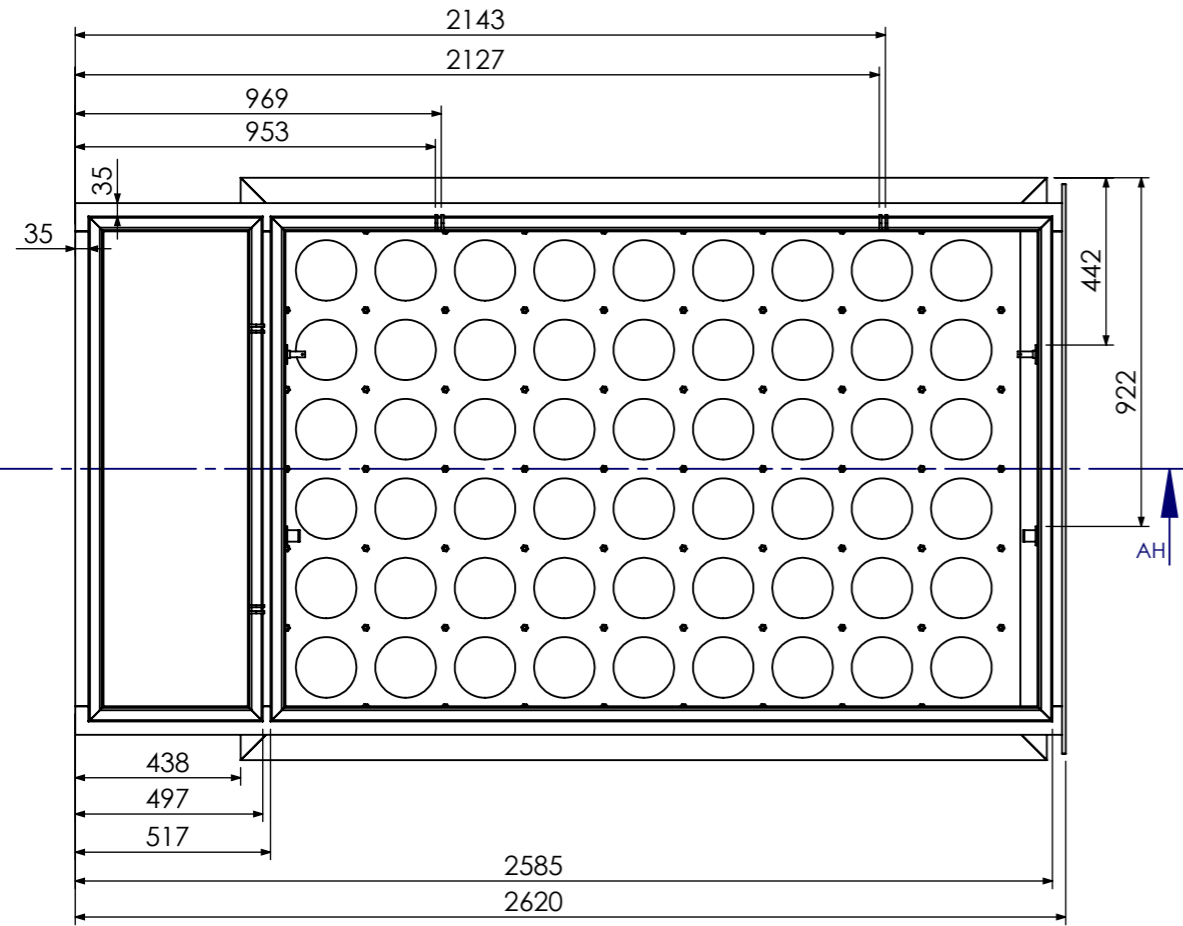
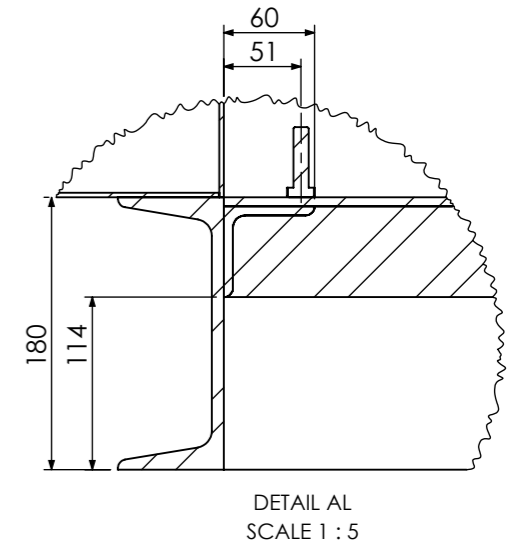
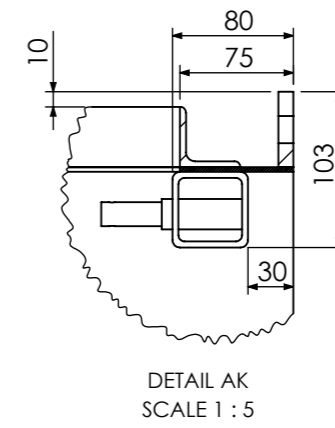
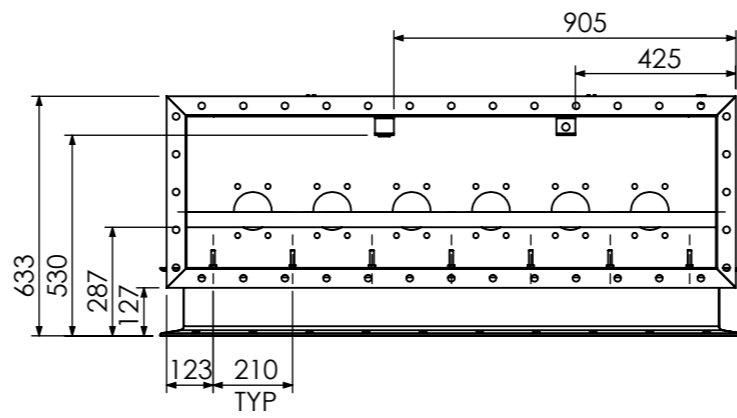
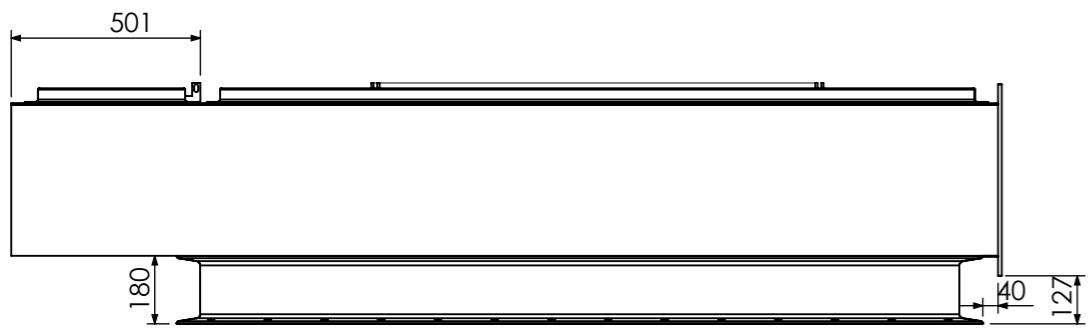

ANG.PROJ.:				گروه صنایع سیمان کرمان	
TELORANCE: ISO 2768-1 (Tolerance Class m) ISO 2768-2 (Tolerance Class k) ISO 13920 (Tolerance Class A)	(سهامی عام)				
UNIT: mm, kg	NAME	SIGNATURE	DATE	TITLE: Bag filter clean gas chamber body	
Document Type: Assem	DRAWN: M.H.Izadi			PART NO.: BF-01-03-01	
QTY.: ***	CHECKED: M.S.Arabnejad			Document ID: **	
Revision:	APPROVED: A.Anjomshoa			REF. Document ID:	
Revision Date:	Material: --			Record ID:	
Classification:	WEIGHT: 435.1 Kg			Scale: 1:20	Sheet: 33 of 61
					Size: A3

8 7 6 5 4 3 2 1

F
E
D
C
B
A

F
E
D
C
B
A

8 7 6 5 4 3 2 1

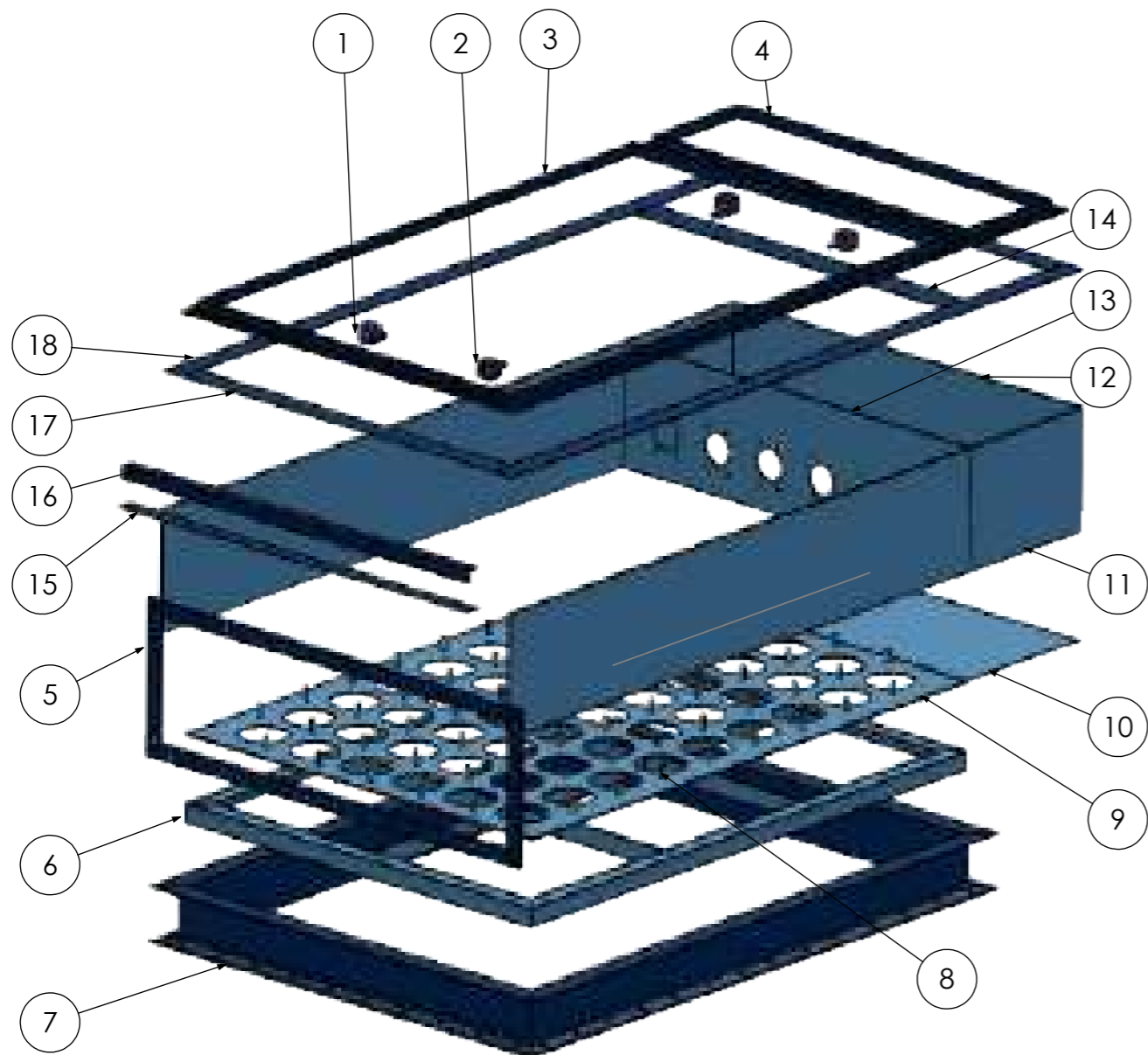
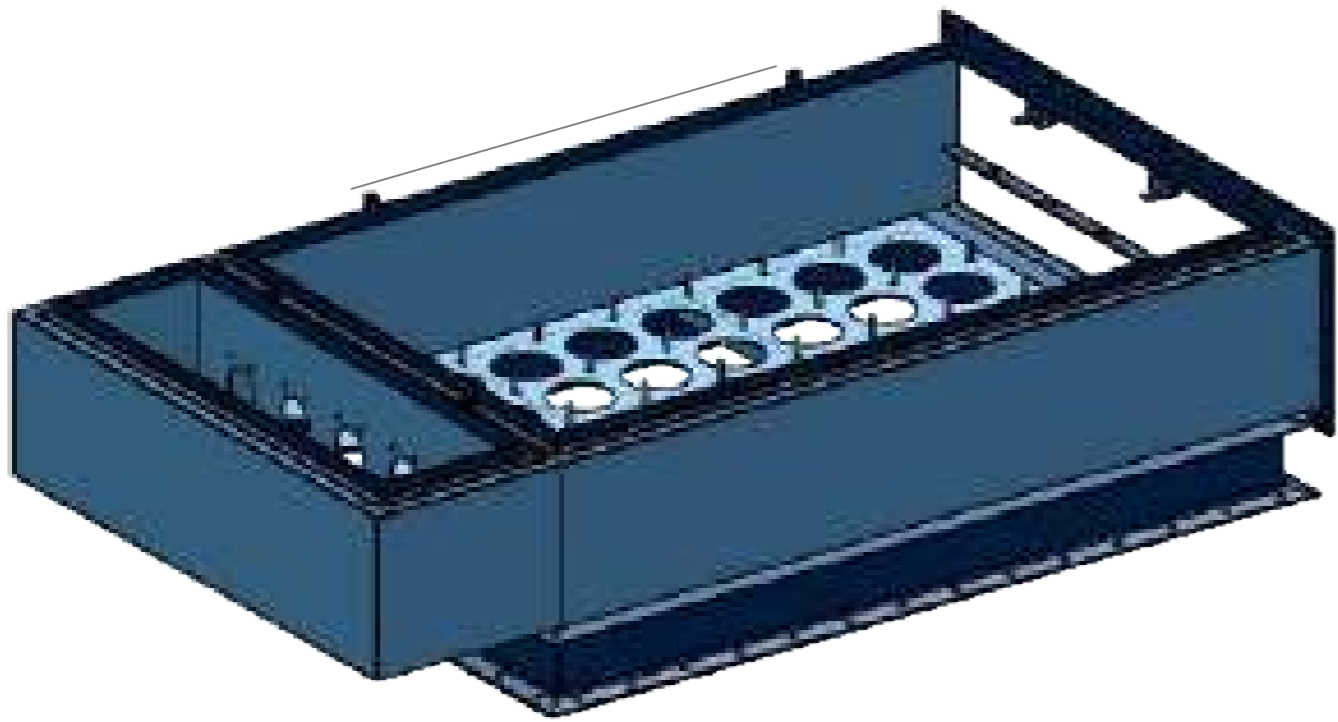

ITEM NO.	PART NUMBER	PART NAME	WEIGHT(KG)	MATERIAL	QTY.
1	BF-01-03-01-01	Bag filter clean gas chamber window holder.02	0.4	--	2
2	BF-01-03-01-02	Bag filter clean gas chamber window holder.03	0.5	--	2
3	BF-01-03-01-03	Bag filter clean gas chamber body part.01	16.0	--	1
4	BF-01-03-01-04	Bag filter clean gas chamber body part.02	8.3	--	1
5	BF-01-03-01-05	Bag filter clean gas chamber body part.03	14.3	--	1
6	BF-01-03-01-06	Bag filter clean gas chamber body part.04	48.9	--	1
7	BF-01-03-01-07	Bag filter clean gas chamber body part.05	152.9	--	1
8	BF-01-03-01-08	Bolt-Din933-M10x40-8.8	0.0	--	66
9	BF-01-03-01-09	Bag filter clean gas chamber body plate.01	80.2	ST37	1
10	BF-01-03-01-10	Bag filter clean gas chamber body plate.02(1400 mm x 505 mm x 3 mm)	16.6	ST37	1
11	BF-01-03-01-11	Bag filter clean gas chamber body plate.03(2650 mm x 400 mm x 3 mm)	24.7	ST37	2
12	BF-01-03-01-12	Bag filter clean gas chamber body plate.04(1400 mm x397 mm x 3 mm)	13.1	ST37	1
13	BF-01-03-01-13	Bag filter clean gas chamber body plate.05	12.0	ST37	1
14	BF-01-03-01-14	Bag filter clean gas chamber body plate.06(1256 mm x 100 mm x 3 mm)	3.0	ST37	1
15	BF-01-03-01-15	Bag filter clean gas chamber body plate.07(1406 mm x 50 mm x 3 mm)	1.7	ST37	1
16	BF-01-03-01-16	Bag filter clean gas chamber body L angel 40x40.01	3.3	ST37	1
17	BF-01-03-01-17	Bag filter clean gas chamber body plate.08(1256 mm x 75 mm x 3 mm)	2.2	ST37	2
18	BF-01-03-01-18	Bag filter clean gas chamber body plate.09(2620 mm x 75 mm x 3 mm)	4.6	ST37	2

ANG.PROJ.:	گروه صنایع سیمان کرمان			
TELORANCE: ISO 2768-1 (Tolerance Class m) ISO 2768-2 (Tolerance Class k) ISO 13920 (Tolerance Class A)	گروه صنایع سیمان کرمان			
UNIT: mm, kg	(سهامی عام)			
Document Type: Assem	NAME	SIGNATURE	DATE	TITLE: Bag filter clean gas chamber body
	DRAWN: M.H.Izadi			PART NO.: BF-01-03-01
QTY.: ***	CHECKED: M.S.Arabnejad			Document ID: **
	APPROVED: A.Anjomshoa			
Revision:				REF. Document ID:
Revision Date:	Material: --			Record ID:
Classification:	WEIGHT: 435.1 Kg	Scale: 1:50	Sheet: 34 of 61	Size: A3

8 7 6 5 4 3 2 1

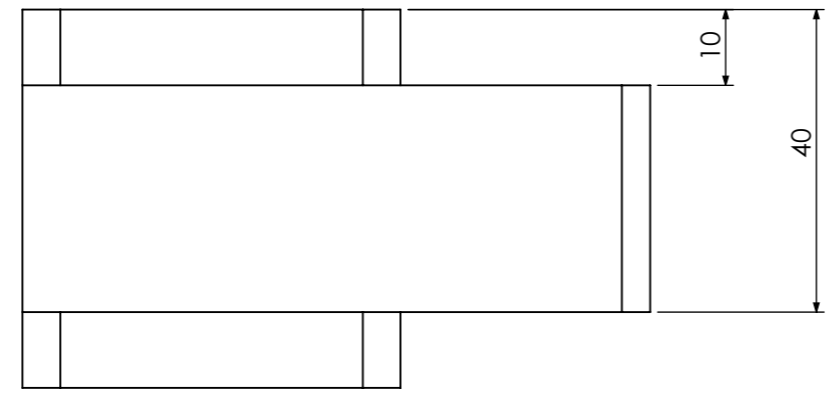
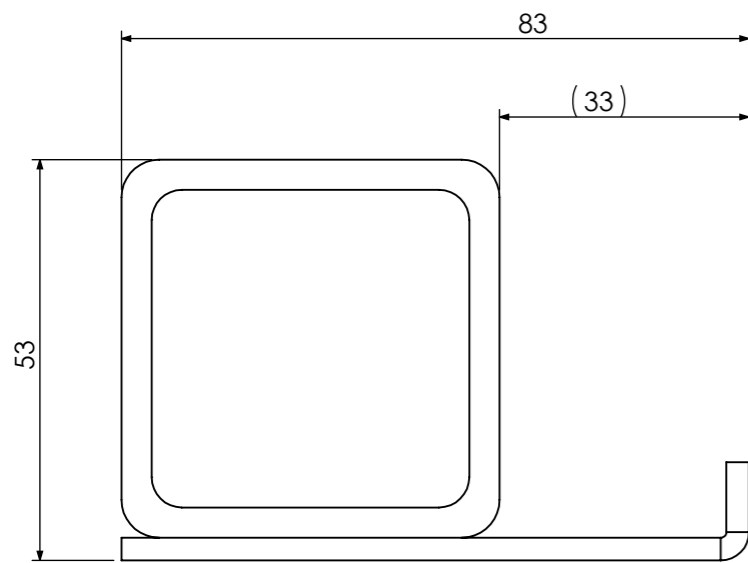

VIEW AO

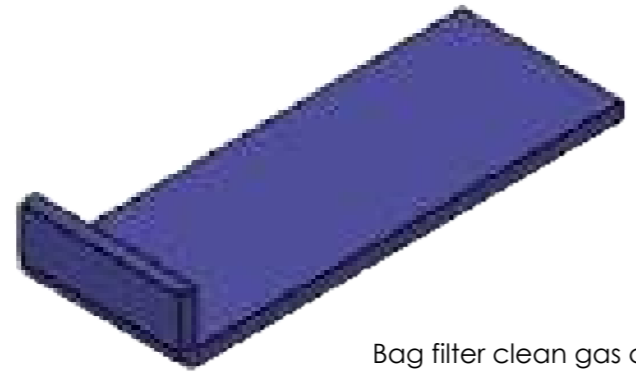
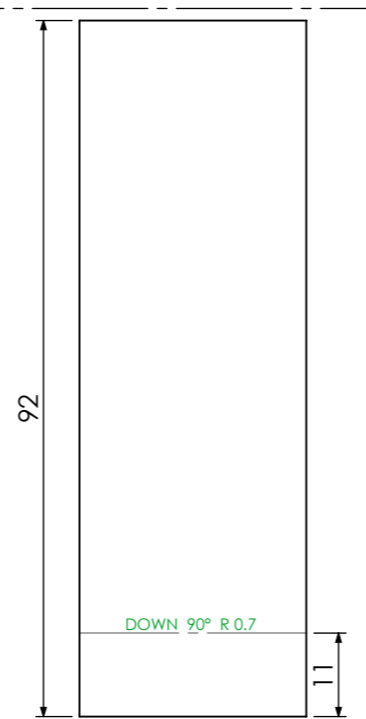
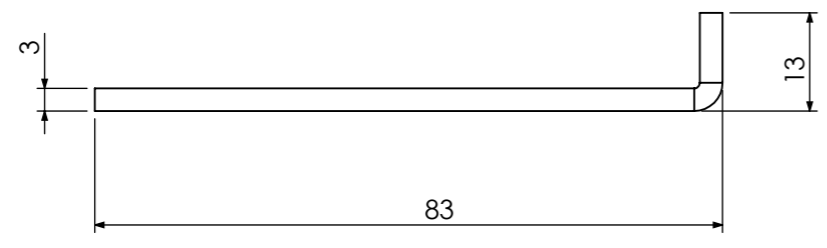
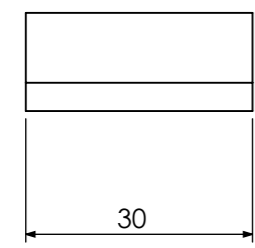
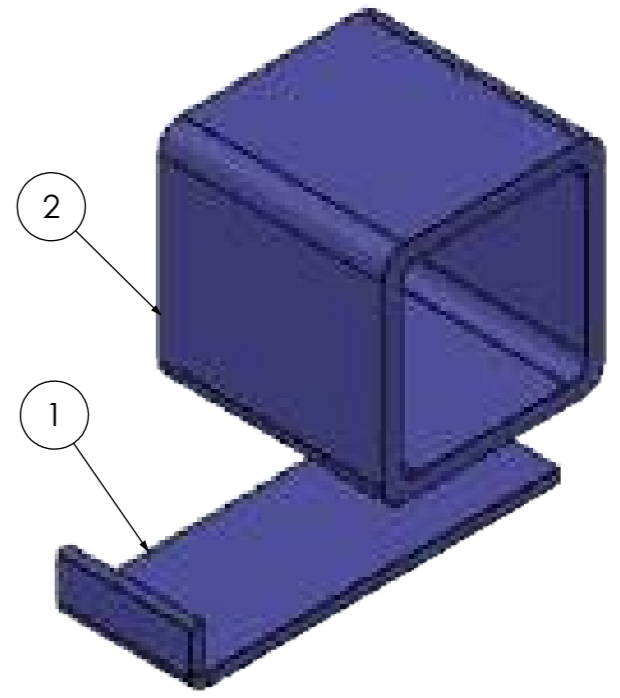
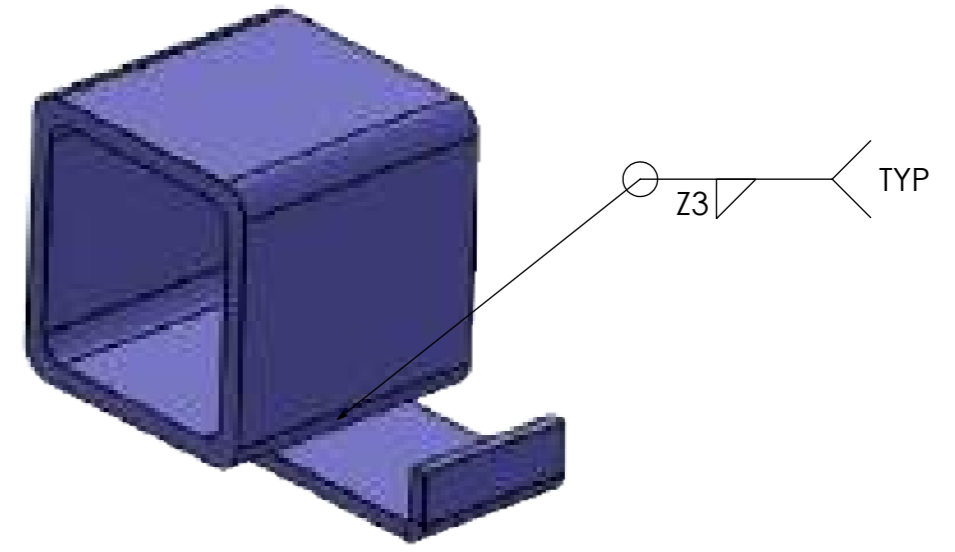

Bag filter clean gas chamber window holder plate.01
BF-01-03-01-01-01

ITEM NO.	PART NUMBER	PART NAME	WEIGHT(KG)	MATERIAL	QTY.
1	BF-01-03-01-01-01	Bag filter clean gas chamber window holder plate.01	0.1	ST37	1
2	BF-01-03-01-01-02	Bag filter clean gas chamber window holder sq tube50x50.01 (L=50 mm simple)	0.3	ST37	1

ANG.PROJ.:	گروه صنایع سیمان کرمان (سهامی عام)			
<small>ISO 2768-1 (Tolerance Class m)</small> <small>TELORANCE: ISO 2768-2 (Tolerance Class k)</small> <small>ISO 13920 (Tolerance Class A)</small>				
UNIT: mm, kg				
Document Type: Assem	NAME	SIGNATURE	DATE	TITLE:
	DRAWN: M.H.Izadi			Bag filter clean gas chamber window holder.02 Bag filter clean gas chamber window holder plate.01
QTY.: ***	CHECKED: M.S.Arabnejad			PART NO.: BF-01-03-01-01 BF-01-03-01-01-01
	APPROVED: A.Anjomshoa			Document ID: **
Revision:				REF. Document ID:
Revision Date:	Material: --			Record ID:
Classification:	WEIGHT: 0.4 Kg	Scale: 1:1	Sheet: 35 of 61	Size: A3

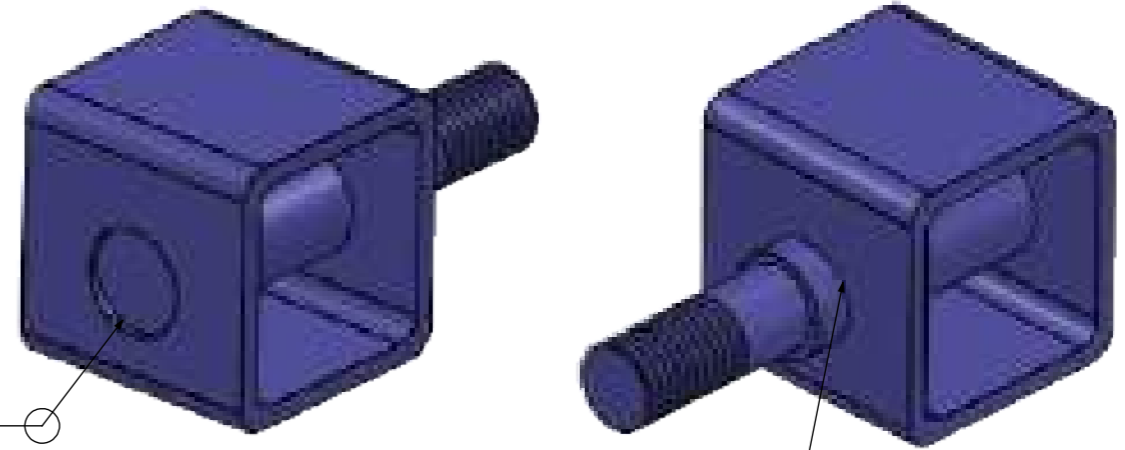
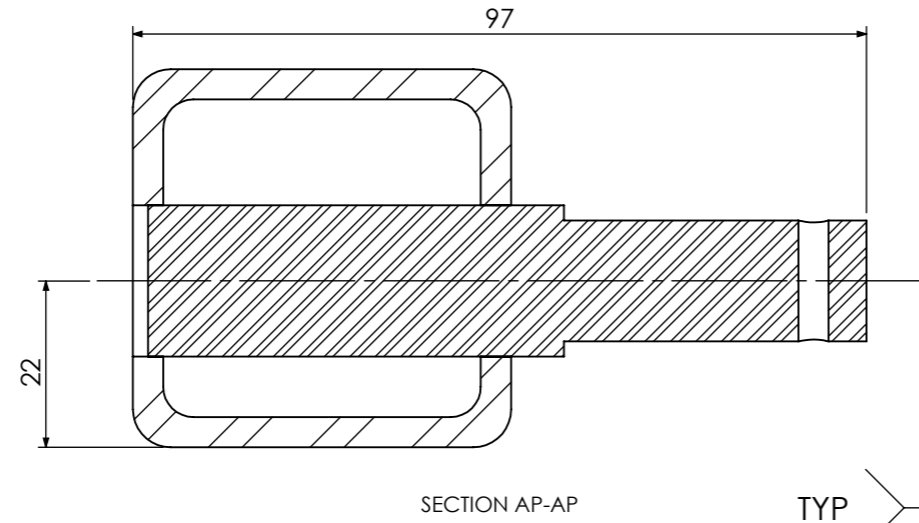
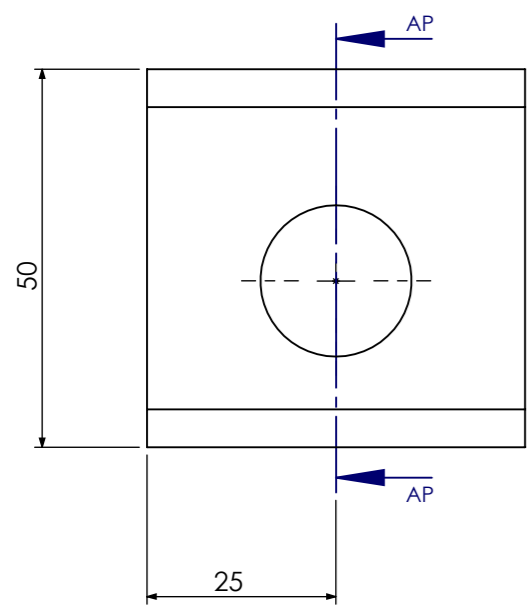

TYP $\frac{3}{}$

TYP $\frac{3}{}$

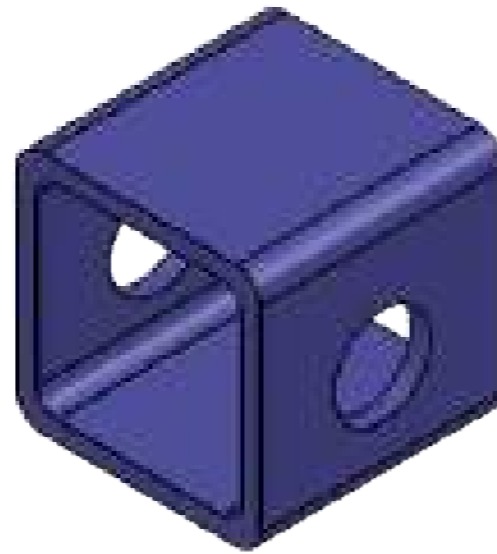
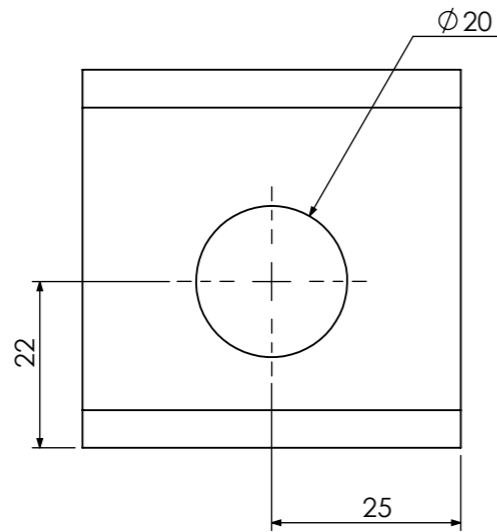
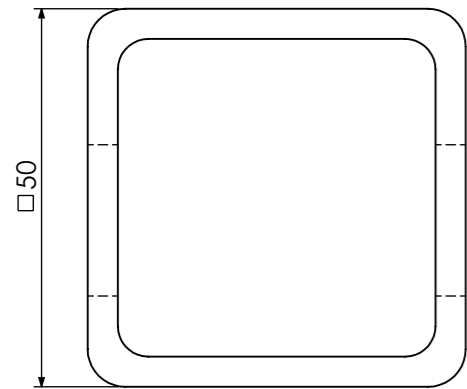

Bag filter clean gas chamber window holder sq tube50x50.02
BF-01-03-01-02-02

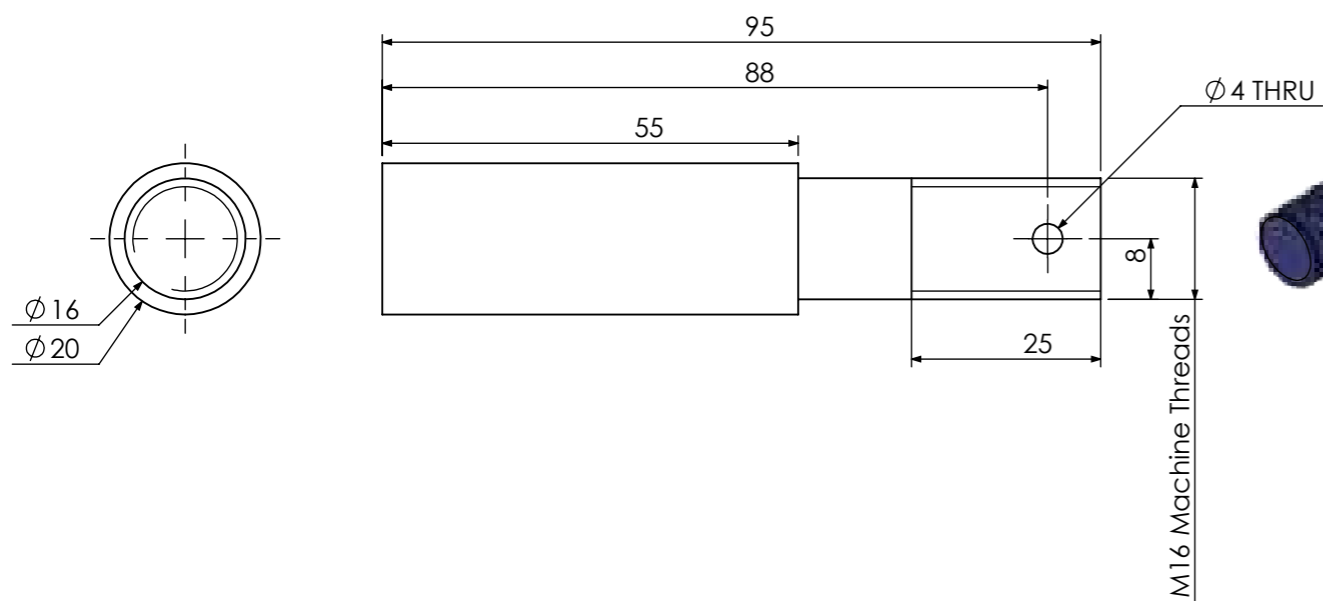
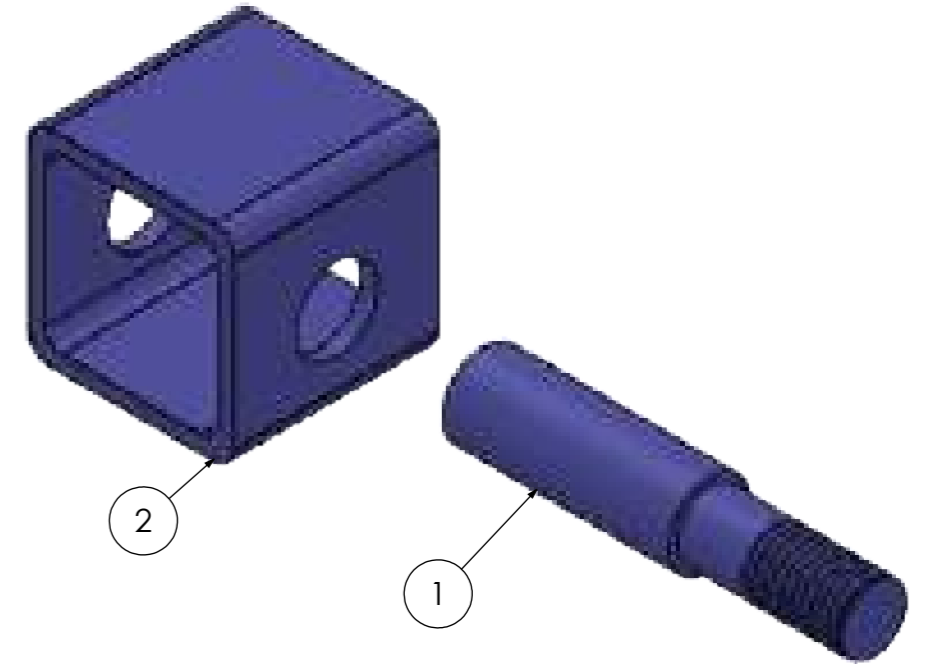

Bag filter clean gas chamber window holder pin.01
BF-01-03-01-02-01

ITEM NO.	PART NUMBER	PART NAME	WEIGHT(KG)	MATERIAL	QTY.
1	BF-01-03-01-02-01	Bag filter clean gas chamber window holder pin.01	0.2	ST37	1
2	BF-01-03-01-02-02	Bag filter clean gas chamber window holder sq tube50x50.02	0.3	ST37	1

ANG.PROJ.:

TELORANCE: ISO 2768-1 (Tolerance Class m)
ISO 2768-2 (Tolerance Class k)
ISO 13920 (Tolerance Class A)

UNIT: mm, kg

Document Type: **Assem**

QTY.: ***

Revision:

Revision Date:

Classification:

WEIGHT: 0.5 Kg

Scale: 1:1

Sheet: 36 of 61

Size: A3

گروه صنایع سیمان کرمان
(سهامی عام)

NAME: M.H.Izadi
SIGNATURE:
DATE:
TITLE: Bag filter clean gas chamber window holder.03
Bag filter clean gas chamber window holder sq tube50x50.02
Bag filter clean gas chamber window holder pin.01

CHECKED: M.S.Arabnejad
APPROVED: A.Anjomshoa

PART NO.: BF-01-03-01-02
BF-01-03-01-02-(01-02)

Document ID: **

REF. Document ID:

Record ID:

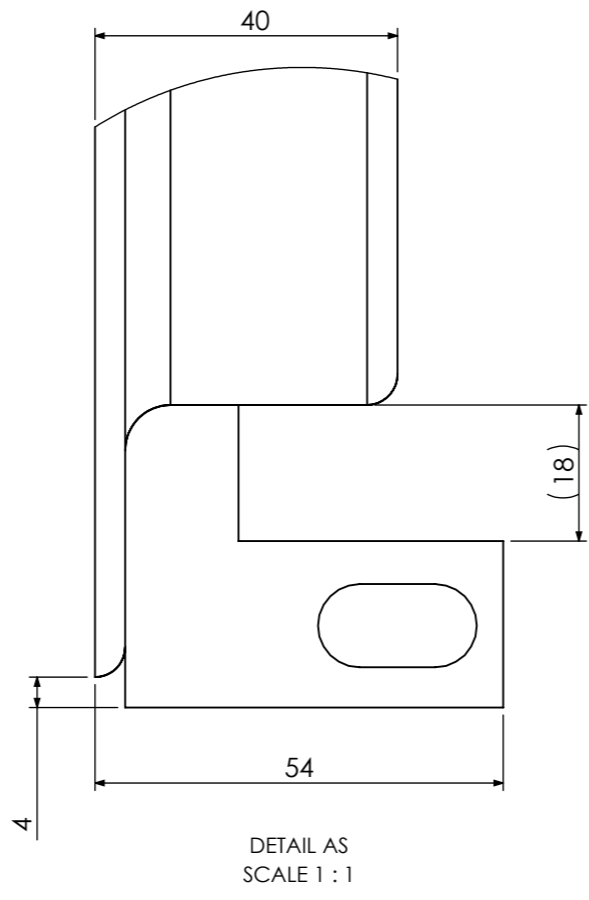
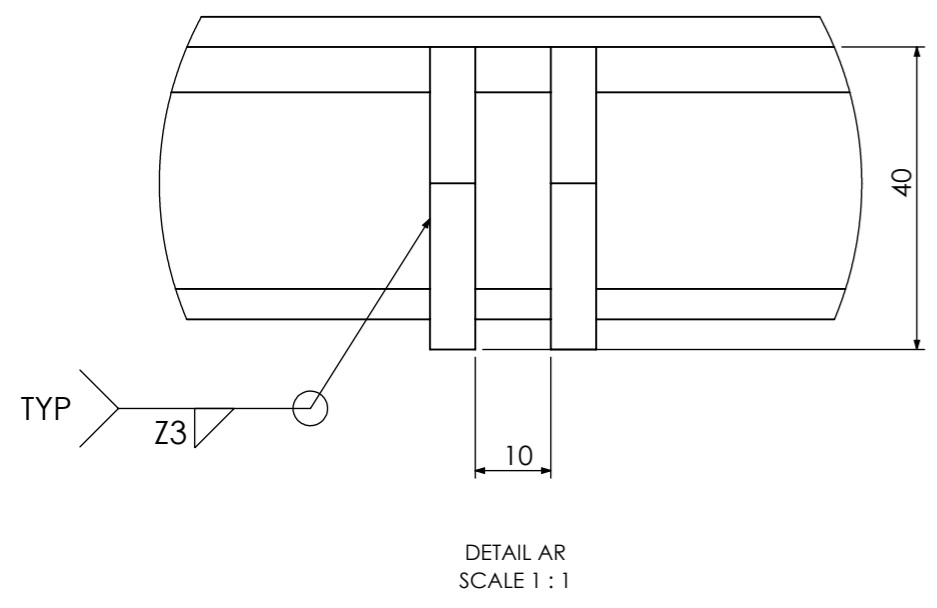
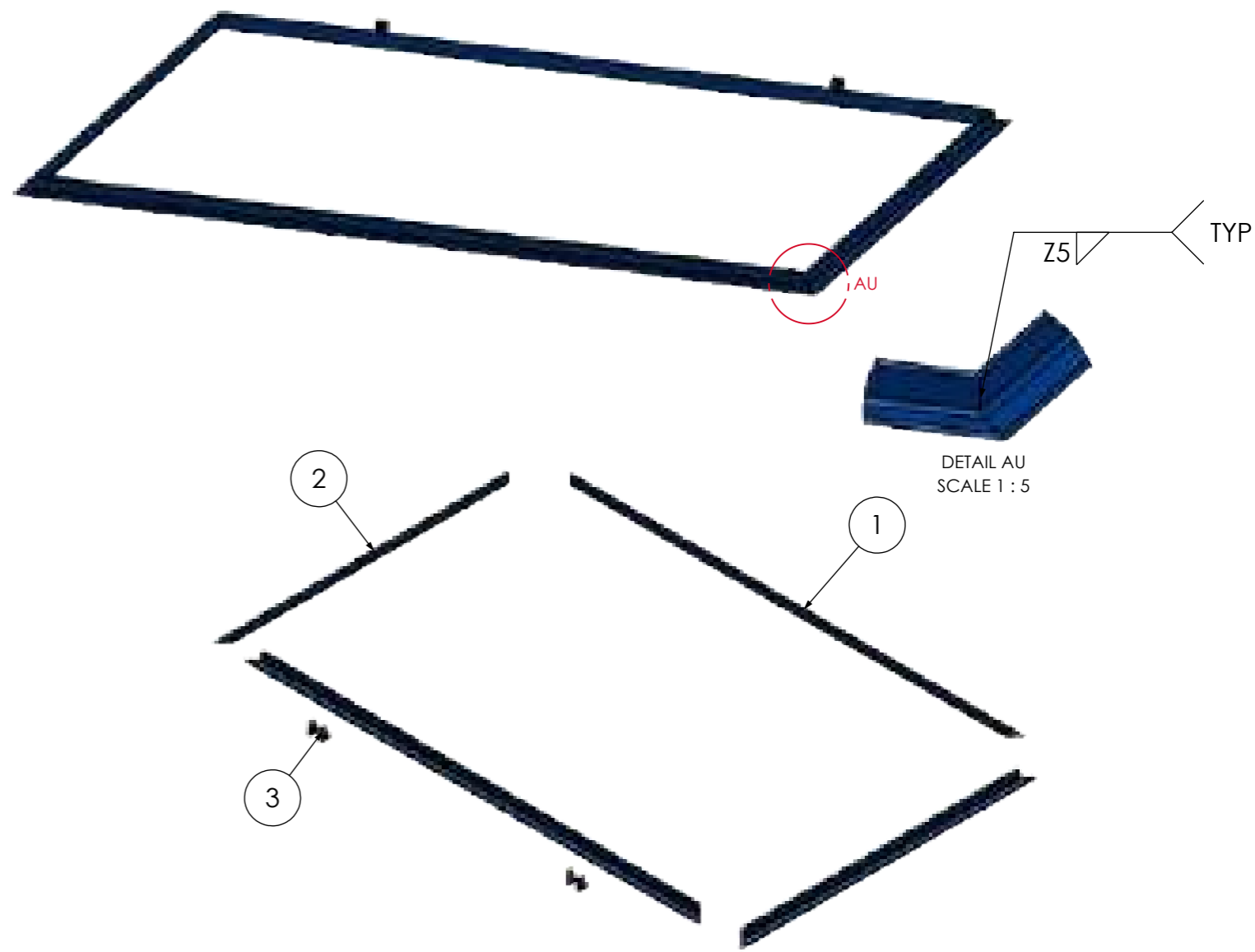
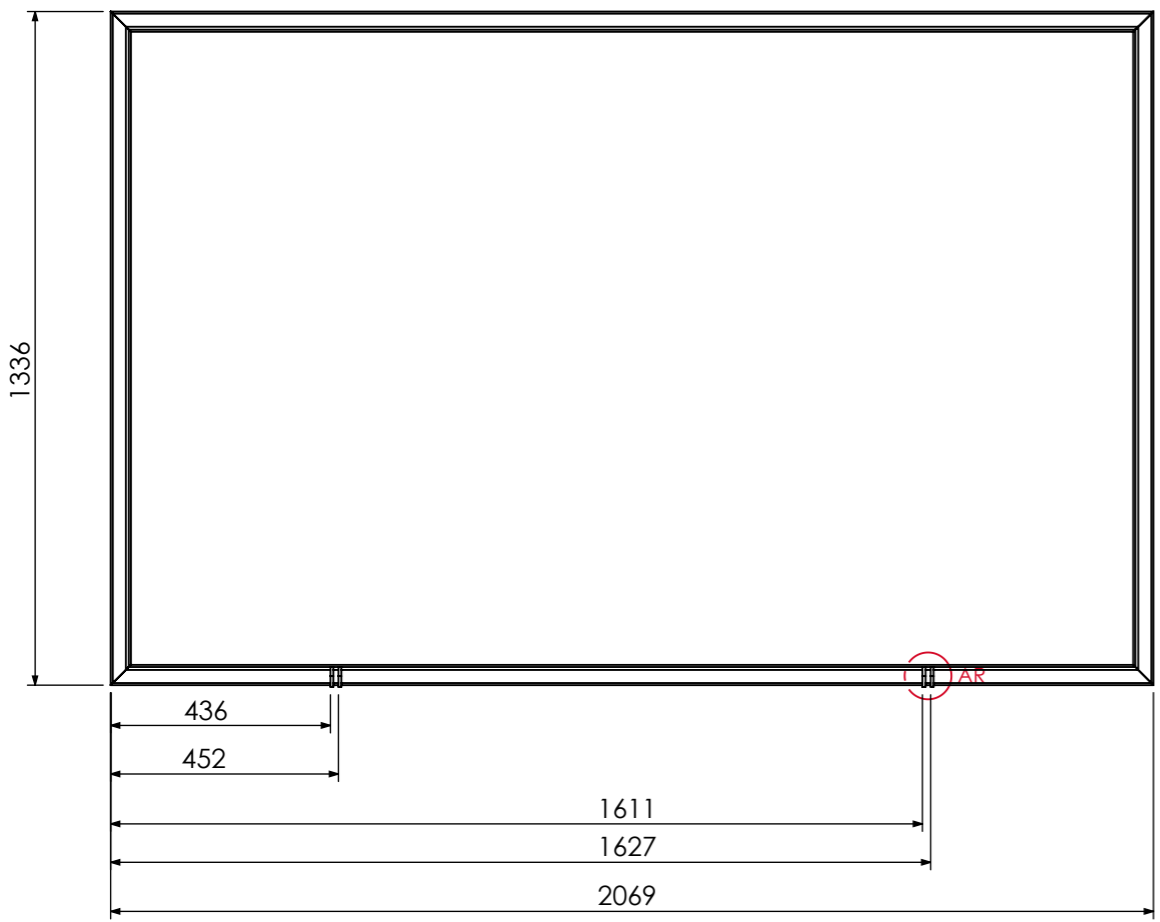

ITEM NO.	PART NUMBER	PART NAME	WEIGHT(KG)	MATERIAL	QTY.
1	BF-01-03-01-03-01	Bag filter clean gas chamber body L angel 40x40.02	4.8	ST37	2
2	BF-01-03-01-03-02	Bag filter clean gas chamber body L angel 40x40.03	3.1	ST37	2
3	BF-01-03-01-03-03	Bag filter clean gas chamber body plate.10	0.1	ST37	4

ANG.PROJ.:	 گروه صنایع سیمان کرمان 			
TELORANCE: ISO 2768-1 (Tolerance Class m) ISO 2768-2 (Tolerance Class k) ISO 13920 (Tolerance Class A)	کارخانه سیمان کرمان (سهامی عام)			
UNIT: mm, kg	NAME	SIGNATURE	DATE	TITLE:
Document Type: Assem	DRAWN: M.H.Izadi			Bag filter clean gas chamber body part.01
QTY.: ***	CHECKED: M.S.Arabnejad			PART NO.: BF-01-03-01-03
	APPROVED: A.Anjomshoa			Document ID: **
Revision:				REF. Document ID:
Revision Date:	Material: --			Record ID:
Classification:	WEIGHT: 16.0 Kg	Scale: 1:10	Sheet: 37 of 61	Size: A3

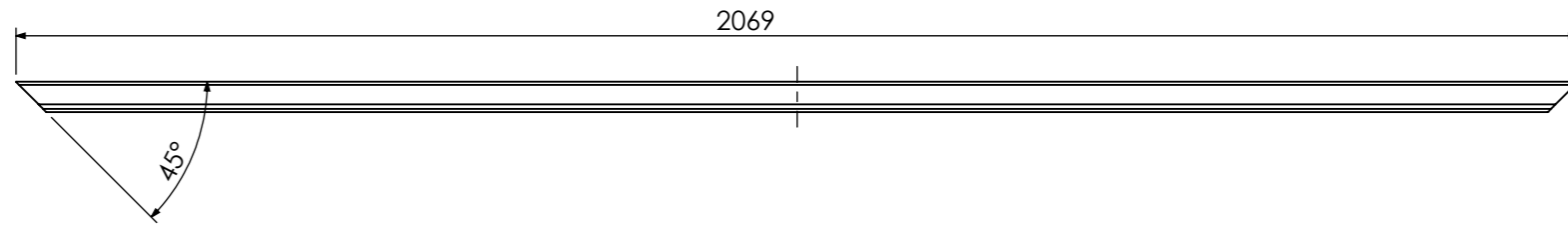
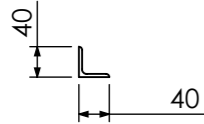

Bag filter clean gas chamber
body L angel 40x40.02
BF-01-03-01-03-01

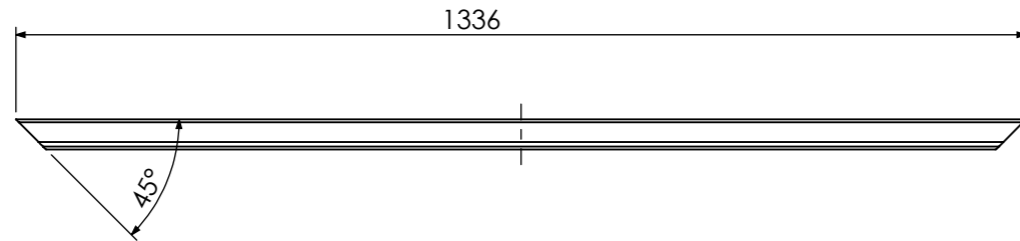
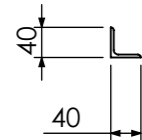

Bag filter clean gas chamber
body L angel 40x40.03
BF-01-03-01-03-02

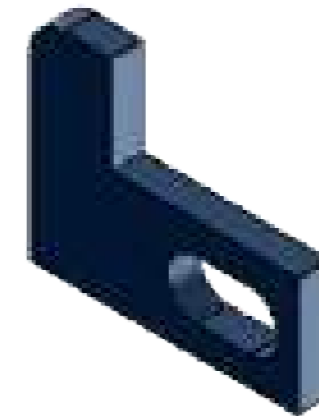
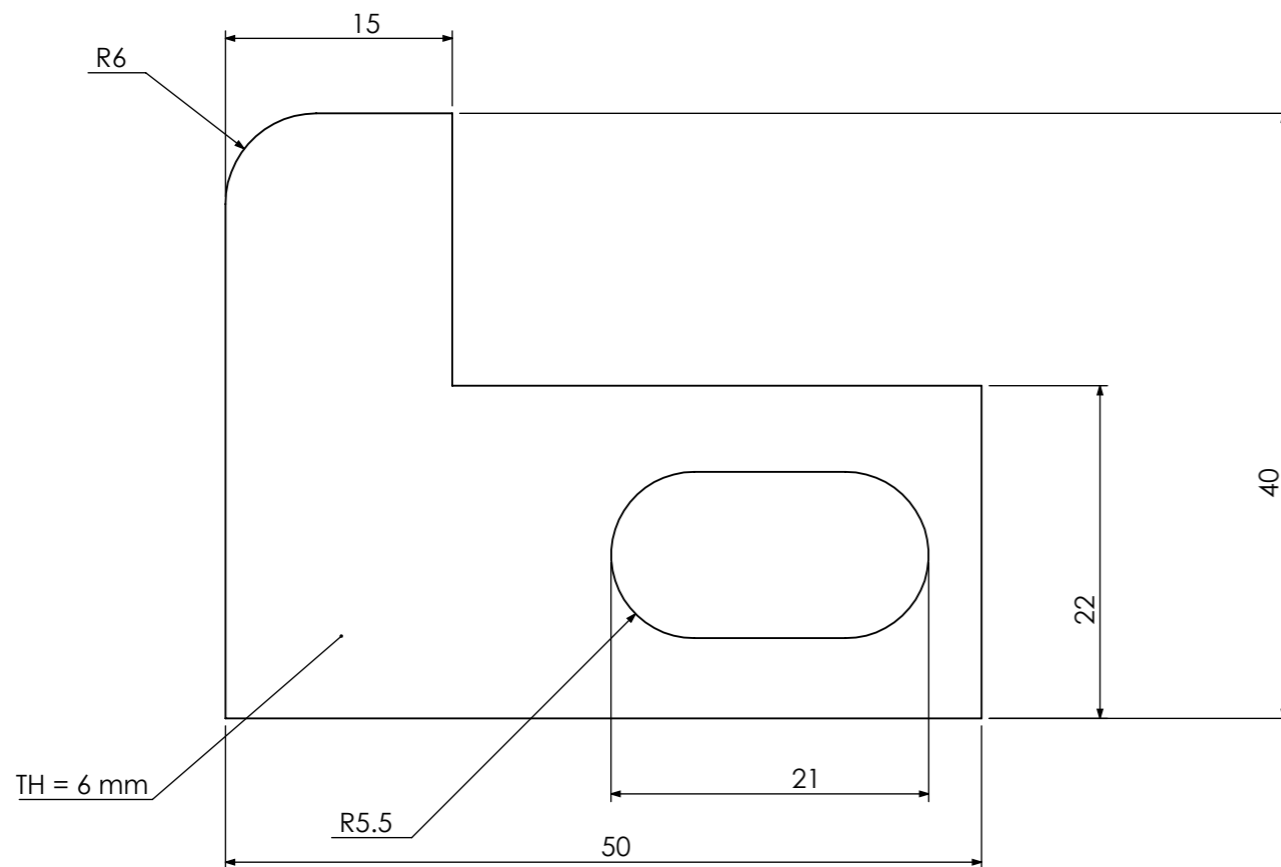

Bag filter clean gas
chamber body plate.10
BF-01-03-01-03-03

ANG.PROJ.:			گروه صنایع سیمان کرمان		
TELORANCE: ISO 2768-1 (Tolerance Class m) ISO 2768-2 (Tolerance Class k) ISO 13920 (Tolerance Class A)	(سهامی عام)				
UNIT: mm, kg					
Document Type: Part	NAME	SIGNATURE	DATE	TITLE:	
	DRAWN	M.H.Izadi		Bag filter clean gas chamber body L angel 40x40(01-02) Bag filter clean gas chamber body plate.10	
QTY: ***	CHECKED	M.S.Arabnejad		PART NO.: BF-01-03-01-03-(01-02-03)	
	APPROVED	A.Anjomshoa		Document ID: **	
Revision:				REF. Document ID:	
Revision Date:	Material: --			Record ID:	
Classification:	WEIGHT: 4.8 Kg	Scale: 1:20		Sheet: 38 of 61	Size: A3

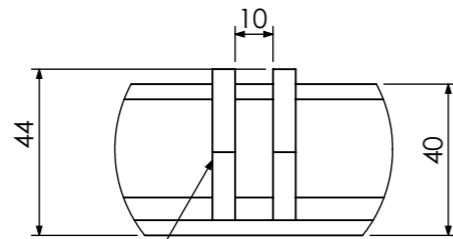
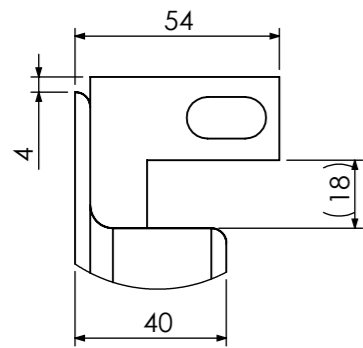
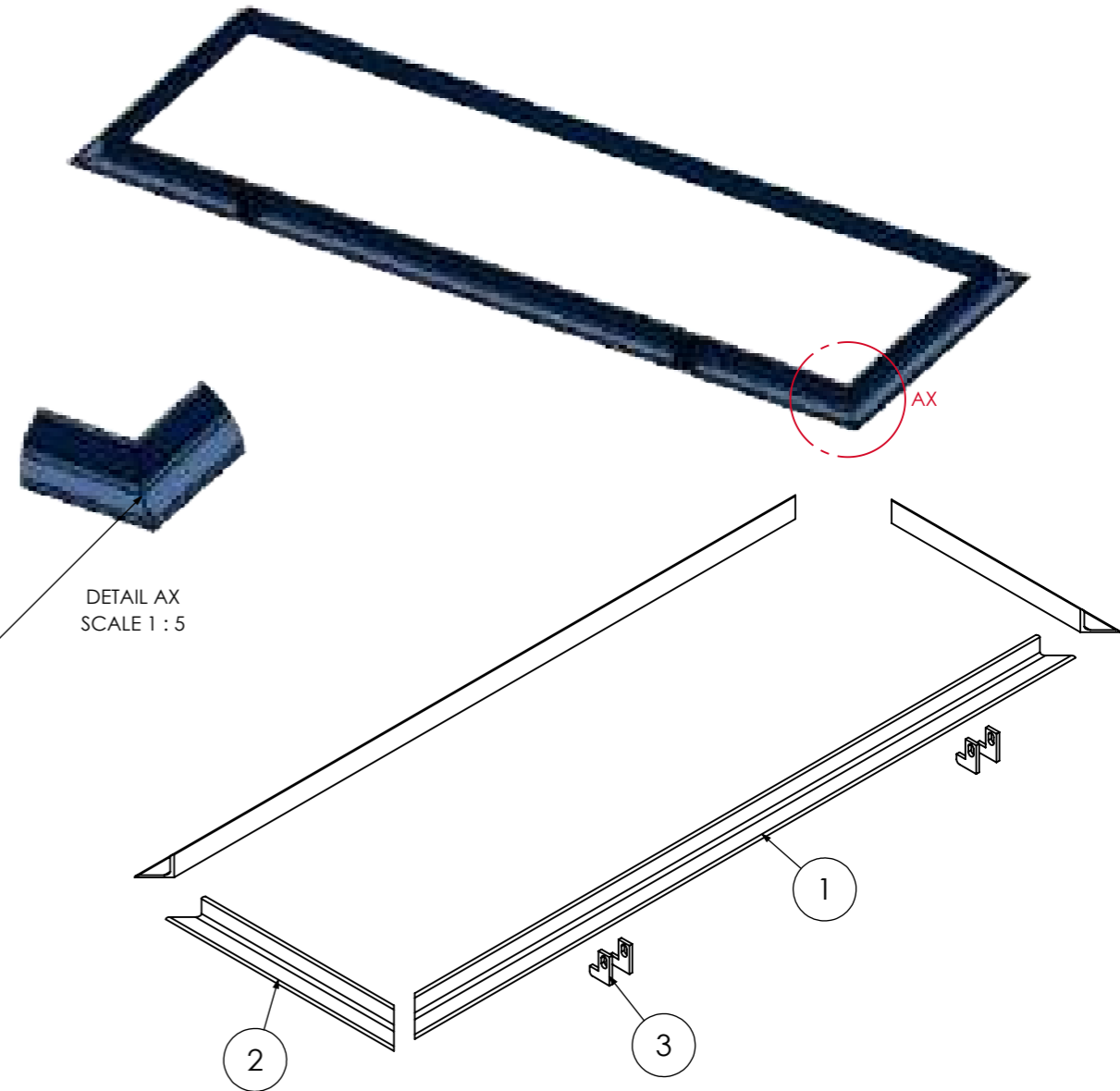
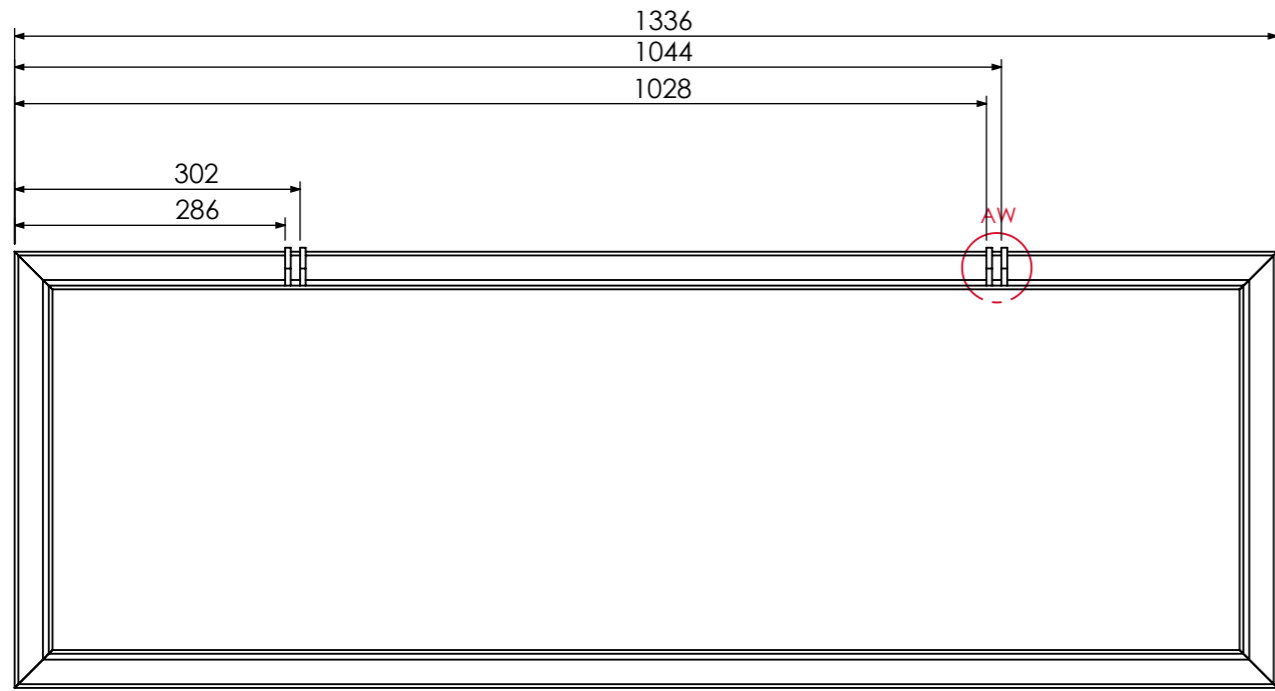

DETAIL AV
SCALE 1 : 2

DETAIL AW
SCALE 1 : 2

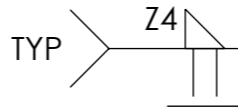
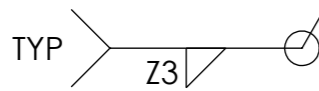

ITEM NO.	PART NUMBER	PART NAME	WEIGHT(KG)	MATERIAL	QTY.
1	BF-01-03-01-03-02	Bag filter clean gas chamber body L angel 40x40.03	3.1	ST37	2
2	BF-01-03-01-04-01	Bag filter clean gas chamber body L angel 40x40.04	1.0	ST37	2
3	BF-01-03-01-03-03	Bag filter clean gas chamber body plate.10	0.1	ST37	4

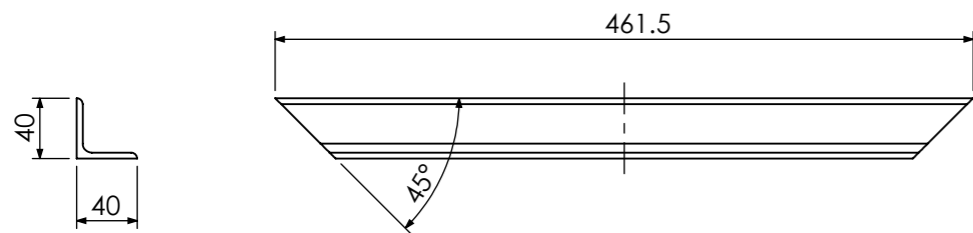

Bag filter clean gas chamber
body L angel 40x40.04
BF-01-03-01-04-01

ANG.PROJ.:				
TELORANCE:	ISO 2768-1 (Tolerance Class m) ISO 2768-2 (Tolerance Class k) ISO 13920 (Tolerance Class A)			
UNIT: mm, kg	گروه صنایع سیمان کرمان (سهامی عام)			
Document Type: Assem	NAME	SIGNATURE	DATE	TITLE:
	M.H.Izadi			Bag filter clean gas chamber body part.02 Bag filter clean gas chamber body L angel 40x40.04
QTY.: ***	CHECKED	M.S.Arabnejad		PART NO.: BF-01-03-01-04 BF-01-03-01-04-01
	APPROVED	A.Anjomshoa		Document ID: **
Revision:				REF. Document ID:
Revision Date:	Material: --			Record ID:
Classification:	WEIGHT: 8.3 Kg	Scale: 1:10	Sheet: 39 of 61	Size: A3

8 7 6 5 4 3 2 1

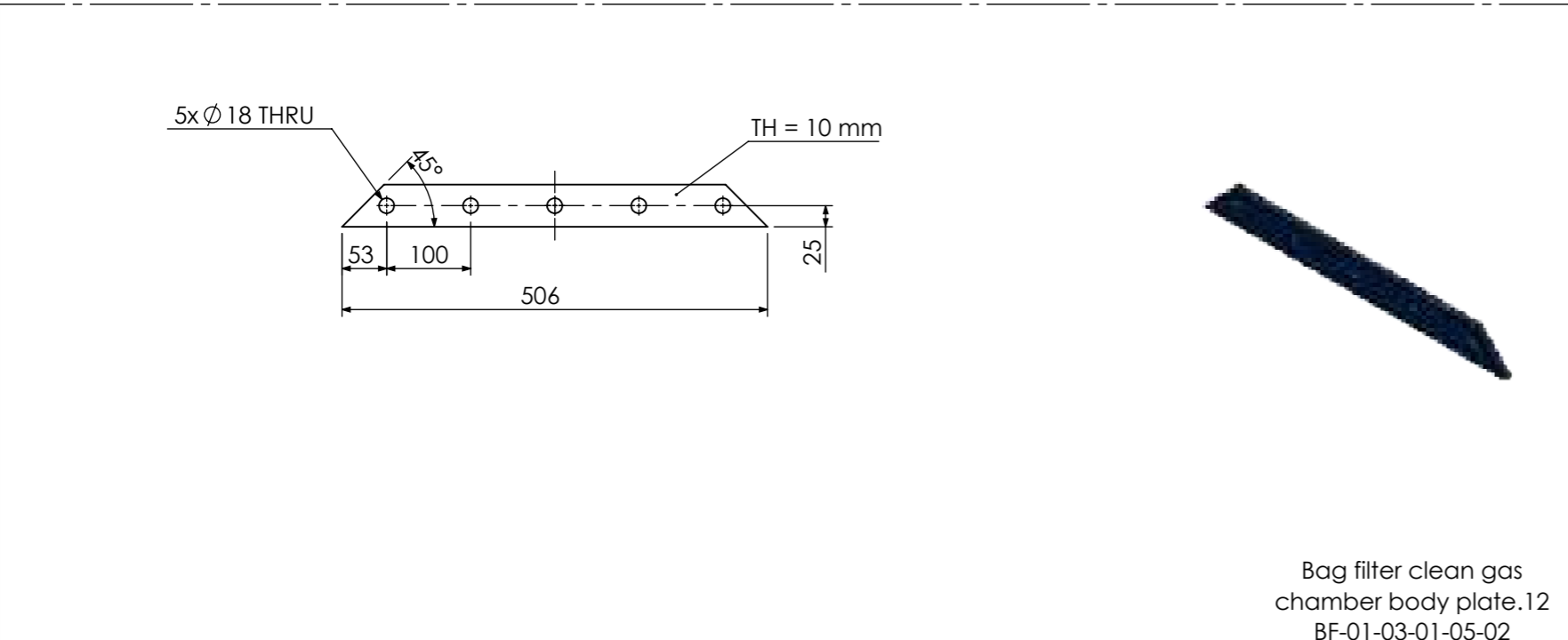
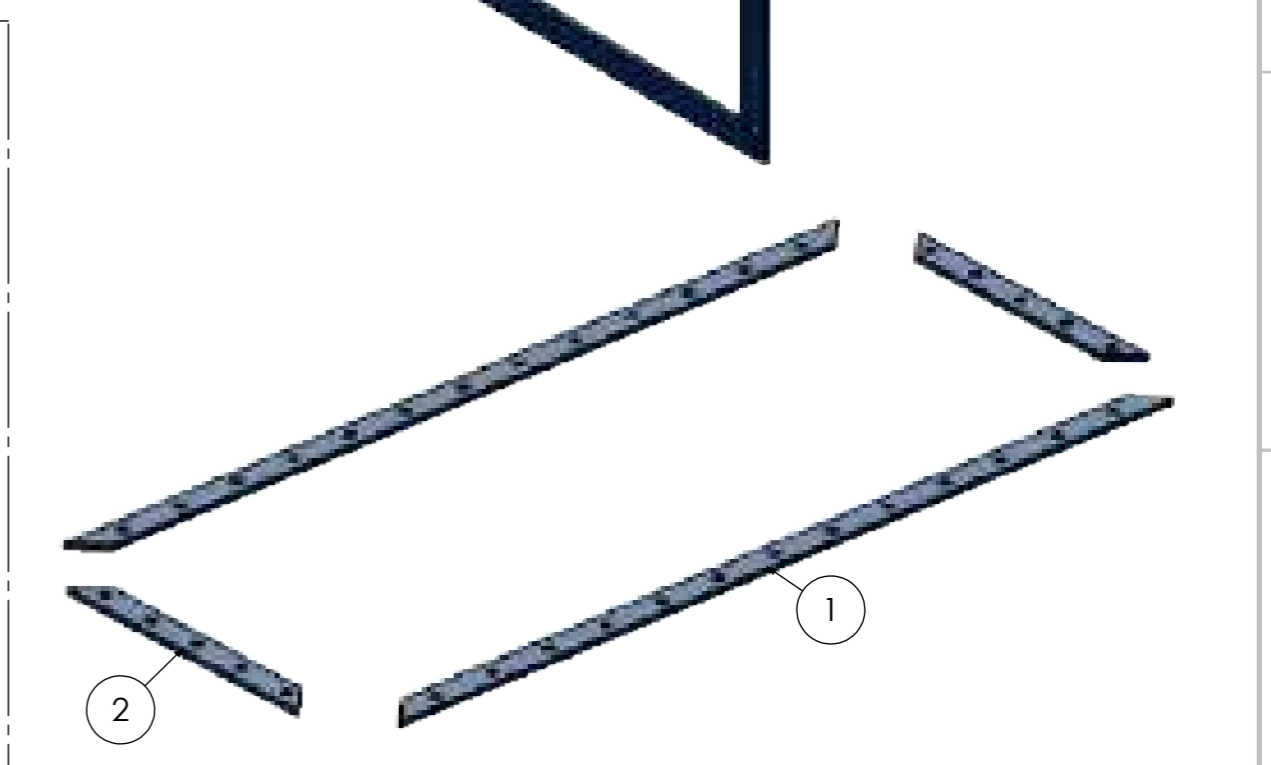
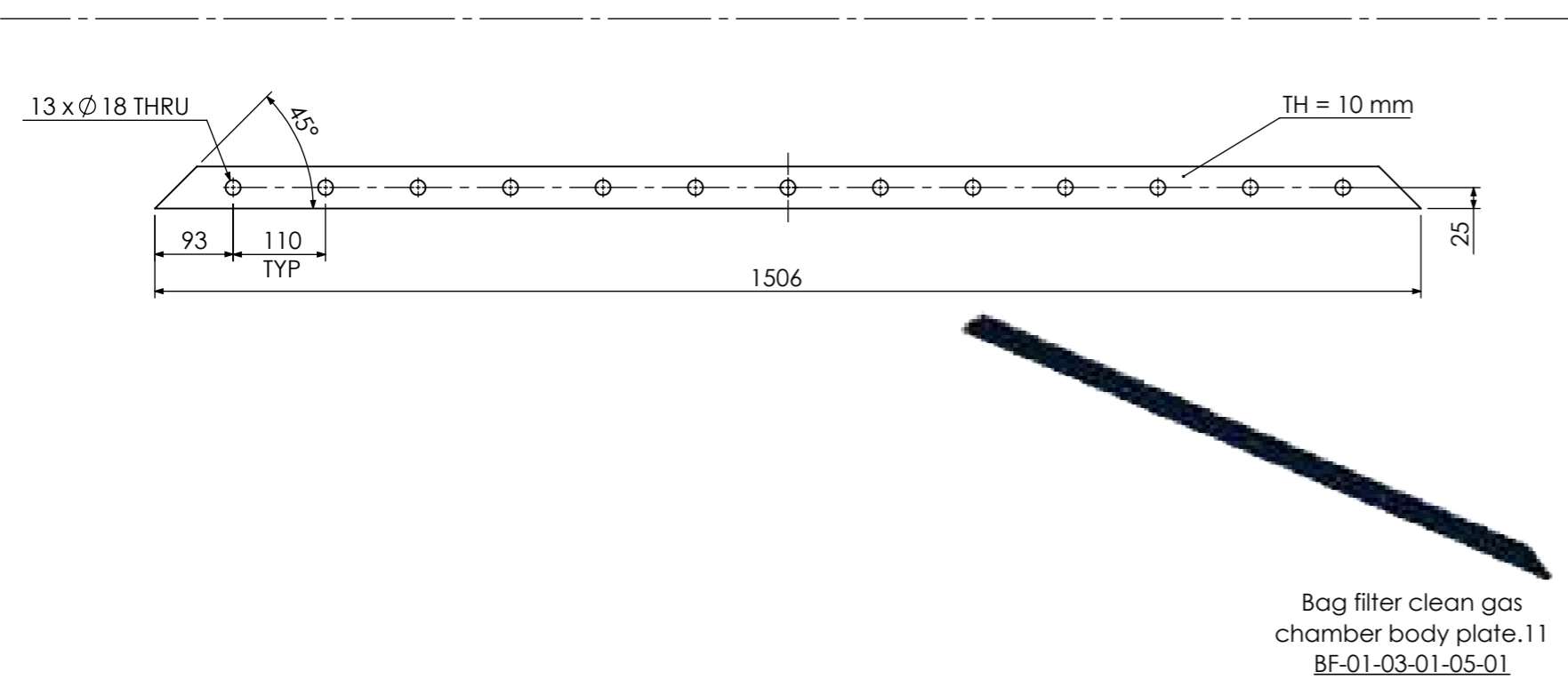
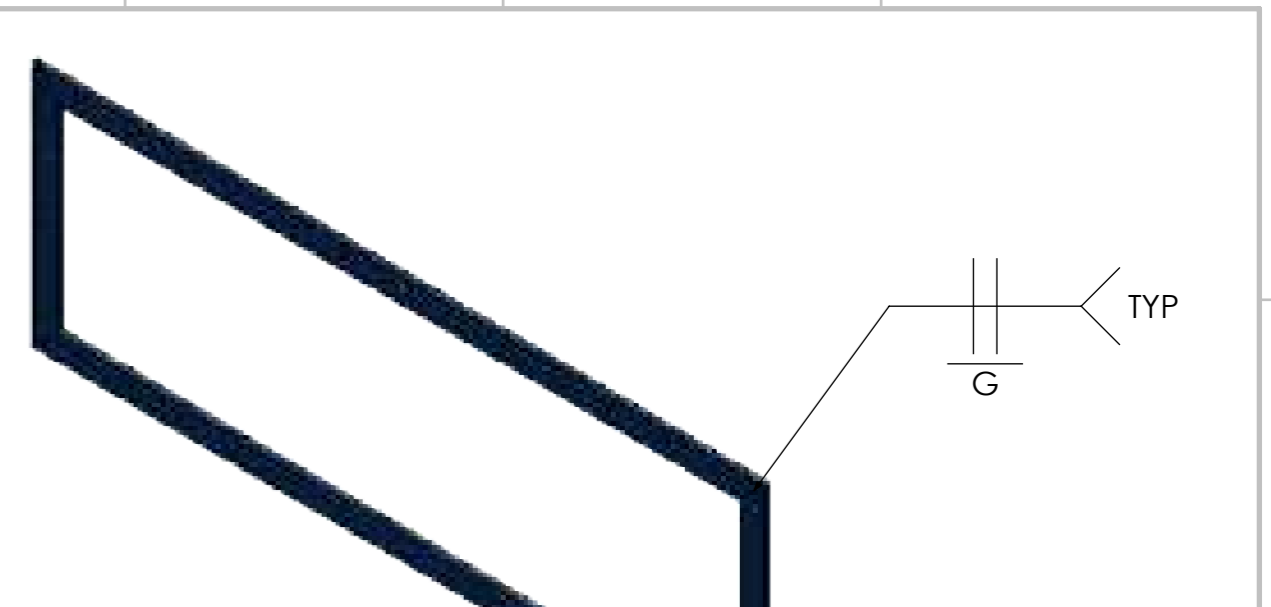
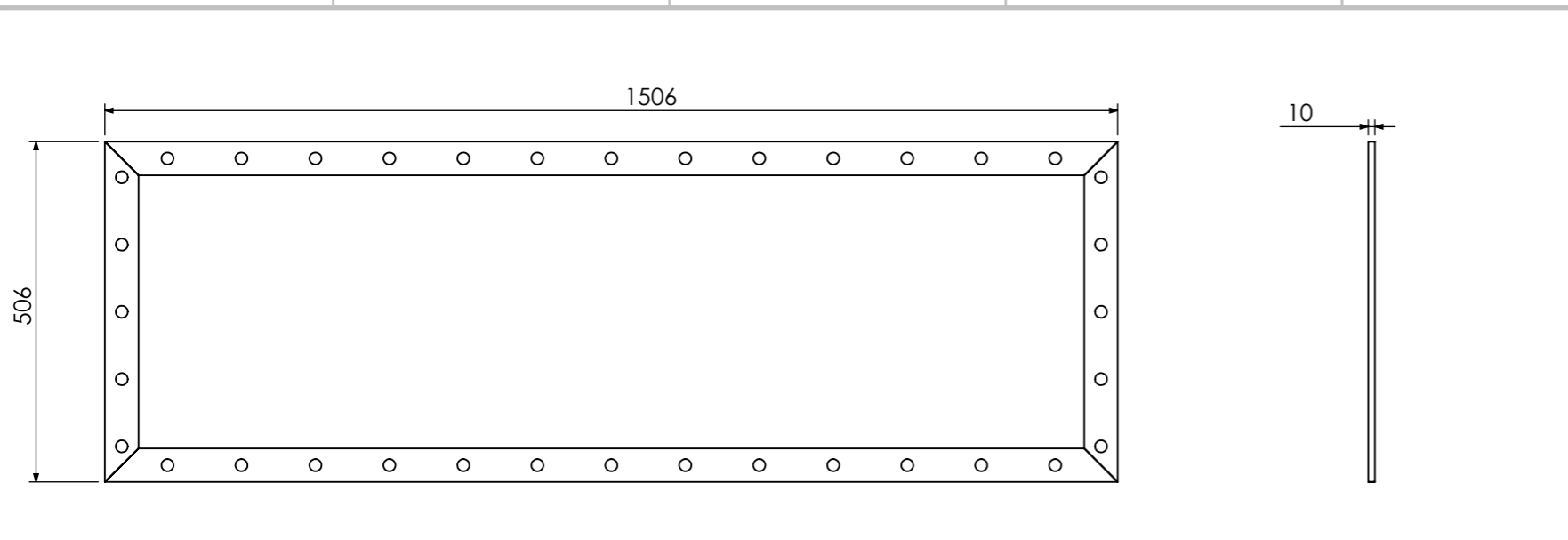

ITEM NO.	PART NUMBER	PART NAME	WEIGHT(KG)	MATERIAL	QTY.
1	BF-01-03-01-05-01	Bag filter clean gas chamber body plate.11	5.5	ST37	2
2	BF-01-03-01-05-02	Bag filter clean gas chamber body plate.12	1.7	ST37	2

ANG.PROJ.:			گروه صنایع سیمان کرمان (سهامی عام)		
Document Type: Assem	NAME	SIGNATURE	DATE	TITLE:	
	DRAWN: M.H.Izadi			Bag filter clean gas chamber body part.03 Bag filter clean gas chamber body plate(11-12)	
QTY.: ***	CHECKED: M.S.Arabnejad			PART NO.: BF-01-03-01-05 BF-01-03-01-05-(01-02)	
	APPROVED: A.Anjomshoa			Document ID: **	
Revision:				REF. Document ID:	
Revision Date:	Material: --			Record ID:	
Classification:	WEIGHT: 14.3 Kg	Scale: 1:20		Sheet: 40 of 61	Size: A3

8 7 6 5 4 3 2 1

8 7 6 5 4 3 2 1

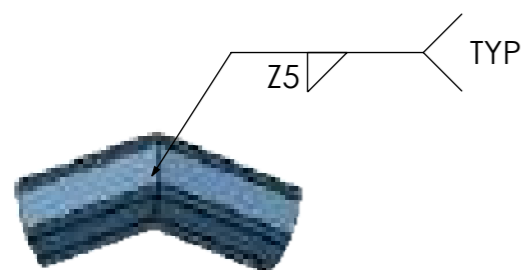
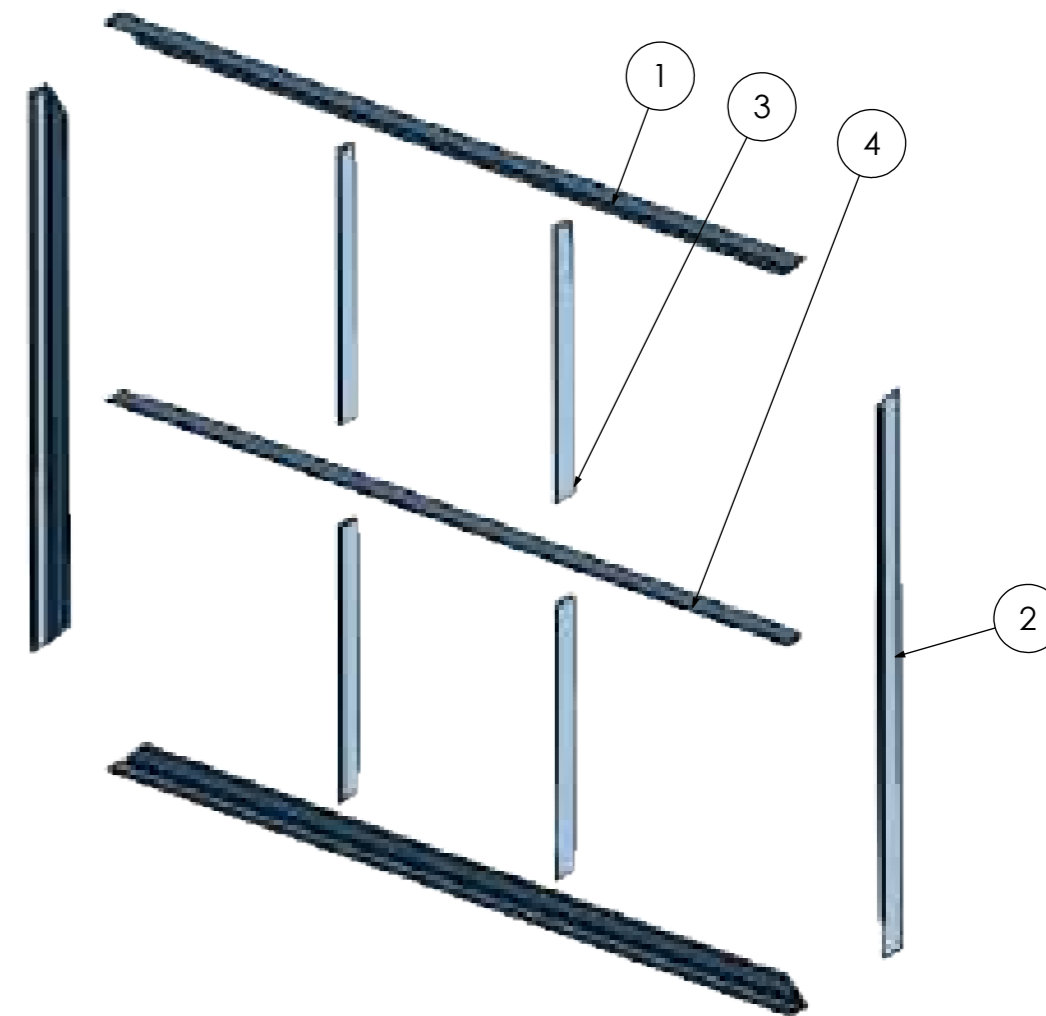
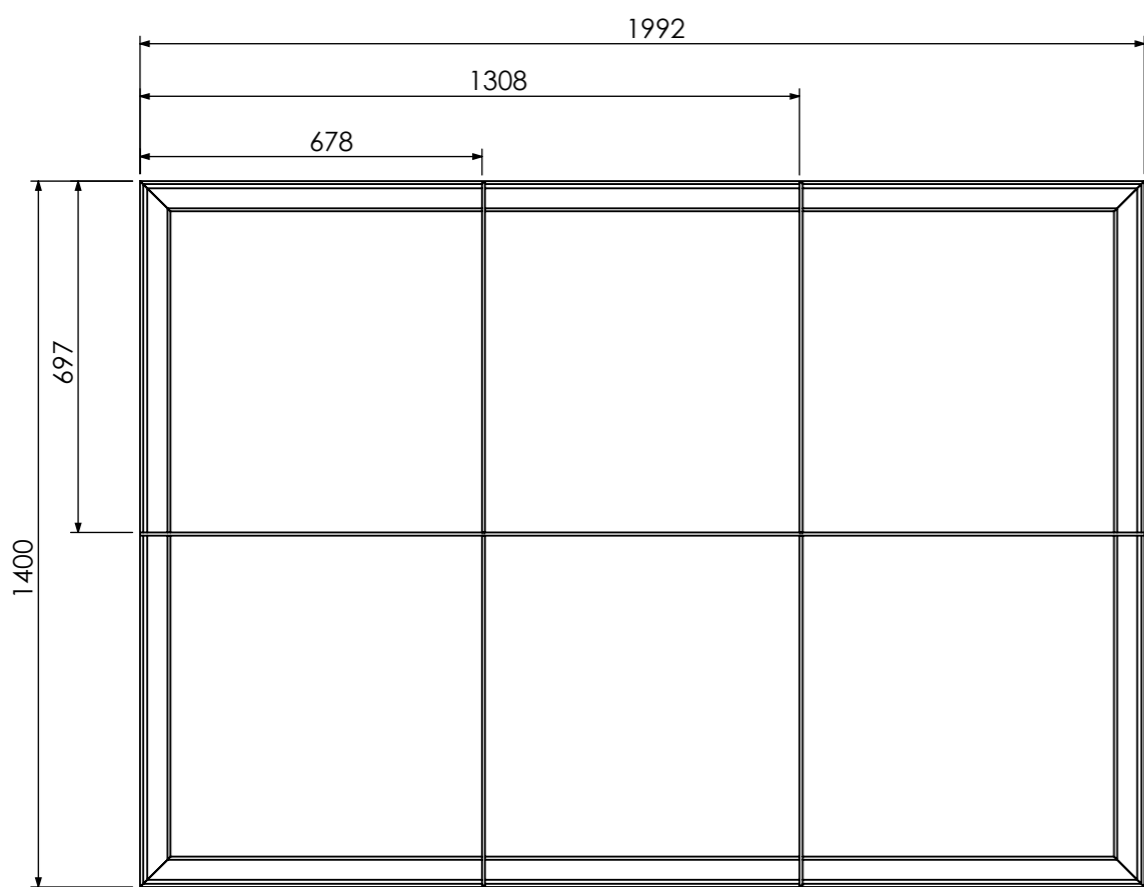

DETAIL AY
SCALE 1 : 7

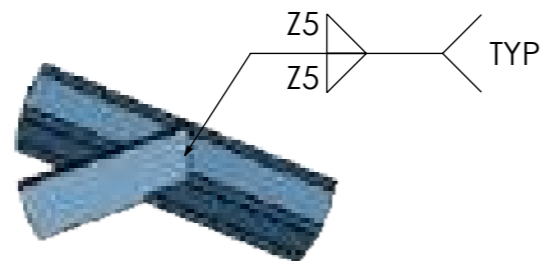

DETAIL AZ
SCALE 1 : 7

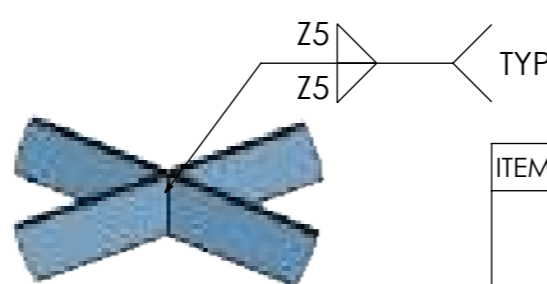

DETAIL BA
SCALE 1 : 7

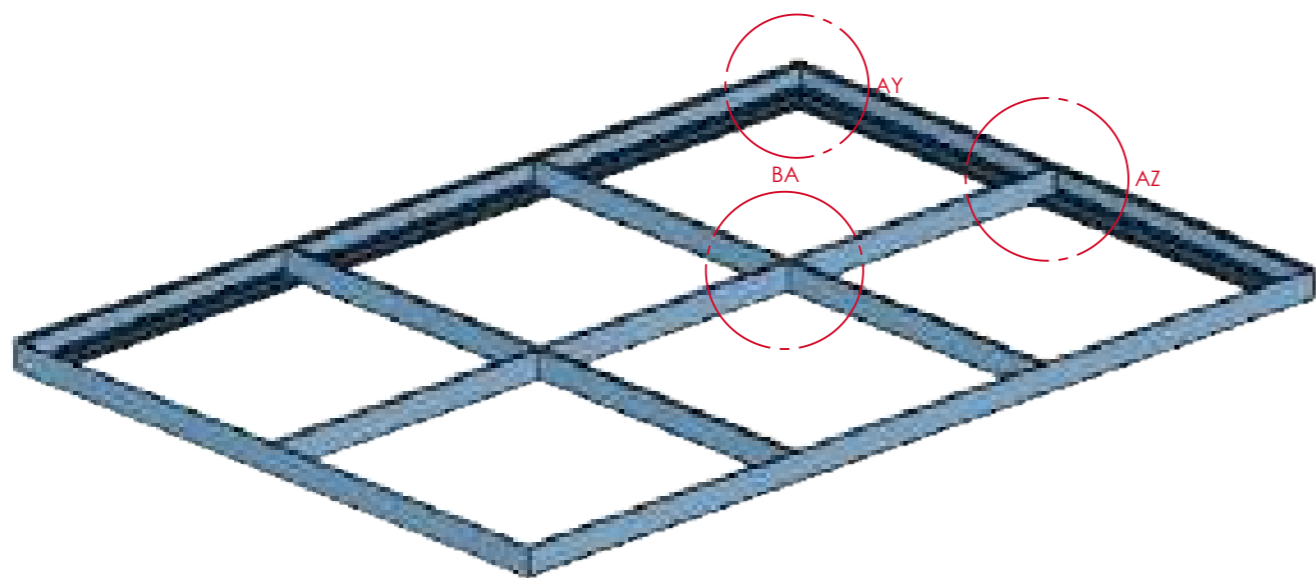

ITEM NO.	PART NUMBER	PART NAME	WEIGHT(KG)	MATERIAL	QTY.
1	BF-01-03-01-06-01	Bag filter clean gas chamber body L angel 60x60.01	10.5	ST37	2
2	BF-01-03-01-06-02	Bag filter clean gas chamber body L angel 60x60.02	7.3	ST37	2
3	BF-01-03-01-06-03	Bag filter clean gas chamber body plate.13	1.9	ST37	4
4	BF-01-03-01-06-04	Bag filter clean gas chamber body plate.14	5.6	ST37	1

ANG.PROJ.:	گروه صنایع سیمان کرمان (سهامی عام)			
<small>ISO 2768-1 (Tolerance Class m)</small> <small>TELORANCE: ISO 2768-2 (Tolerance Class k)</small> <small>ISO 13920 (Tolerance Class A)</small>				
UNIT: mm, kg				
Document Type: Assem	NAME	SIGNATURE	DATE	TITLE:
	DRAWN: M.H.Izadi			Bag filter clean gas chamber body part.04
QTY.: ***	CHECKED: M.S.Arabnejad			PART NO.: BF-01-03-01-06
	APPROVED: A.Anjomshoa			Document ID: **
Revision:				REF. Document ID:
Revision Date:	Material: --			Record ID:
Classification:	WEIGHT: 48.9 Kg	Scale: 1:20	Sheet: 41 of 61	Size: A3

8 7 6 5 4 3 2 1

F

F

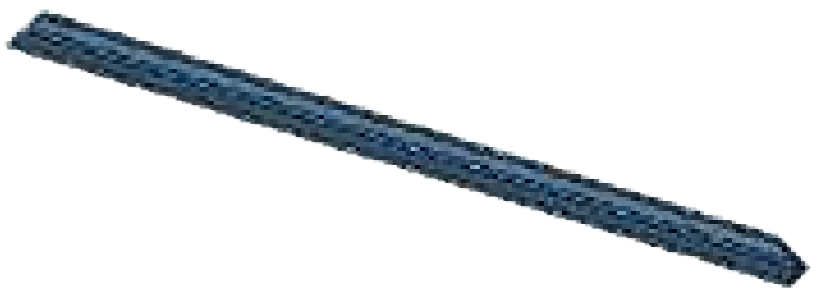
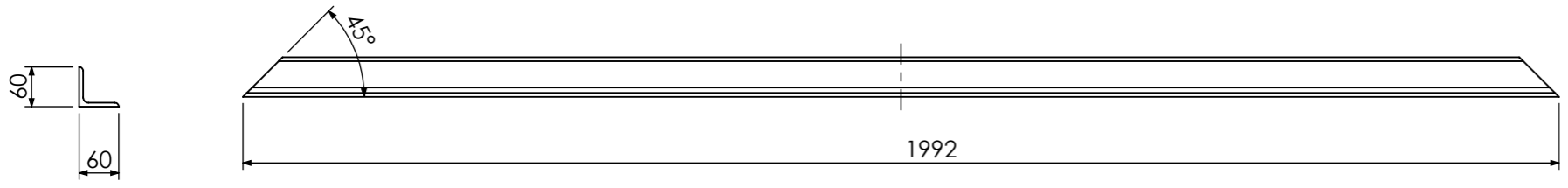

Bag filter clean gas chamber
body L angel 60x60.01
BF-01-03-01-06-01

E

E

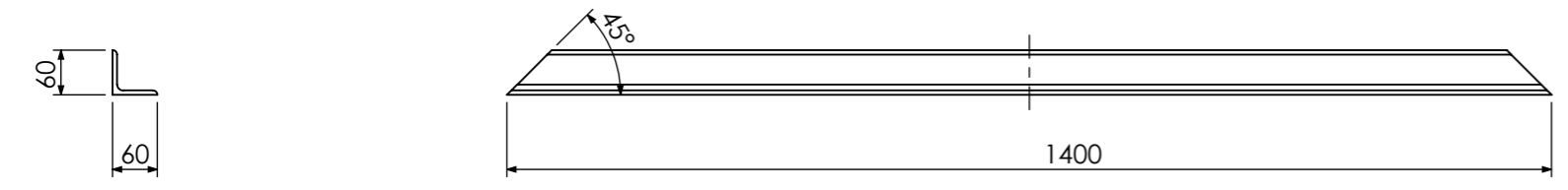

Bag filter clean gas chamber
body L angel 60x60.02
BF-01-03-01-06-02

D

D

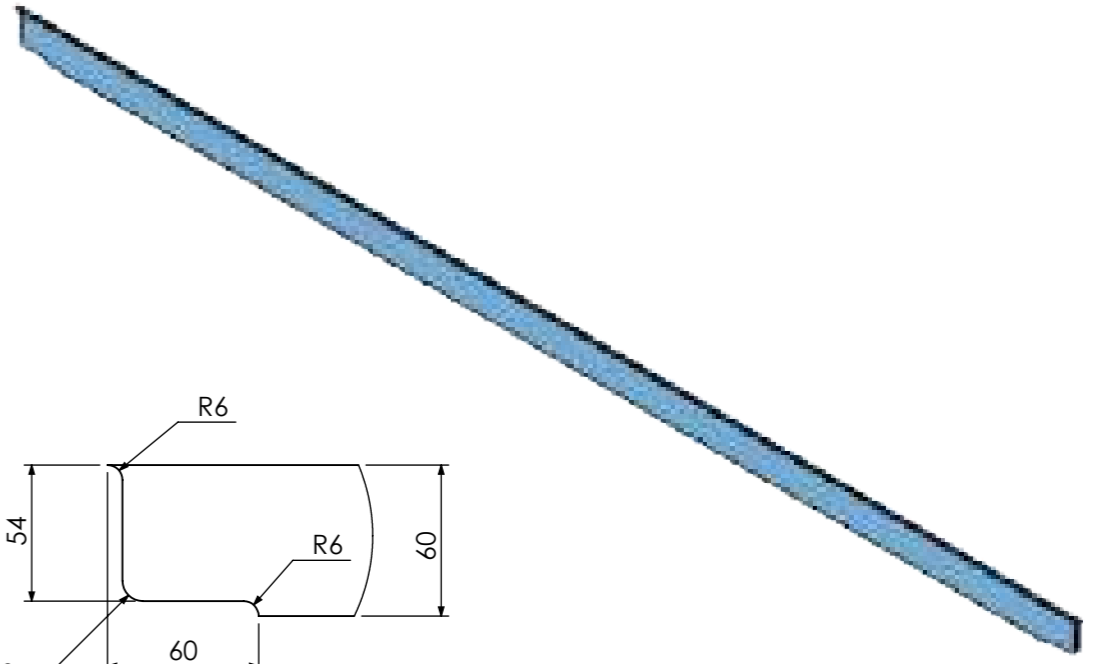
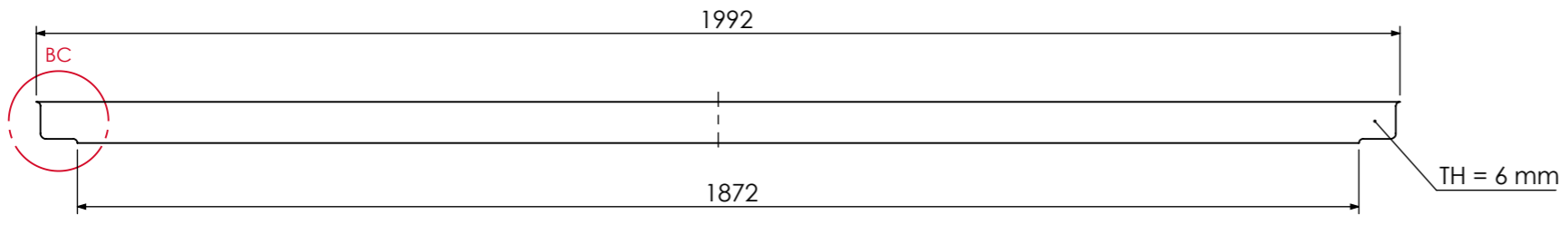

Bag filter clean gas
chamber body plate.14
BF-01-03-01-06-04

C

C

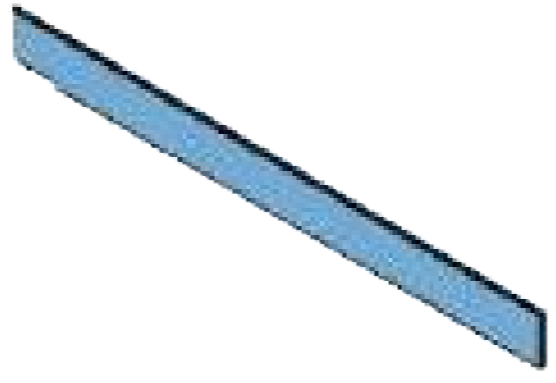
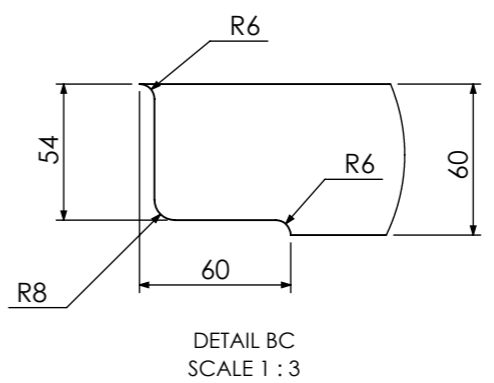
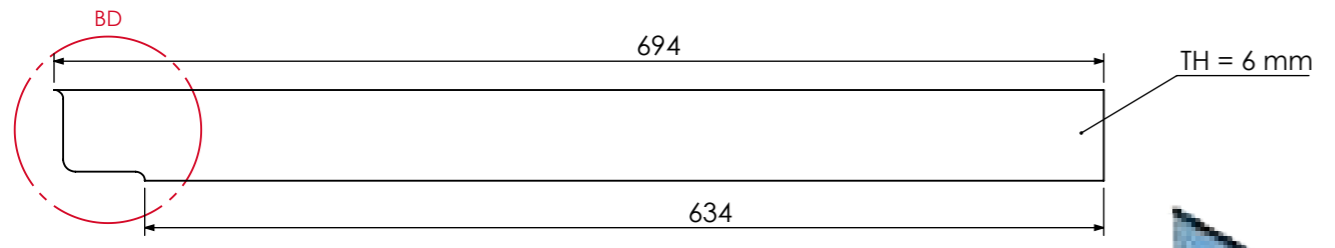



Bag filter clean gas
chamber body plate.13
BF-01-03-01-06-03

B

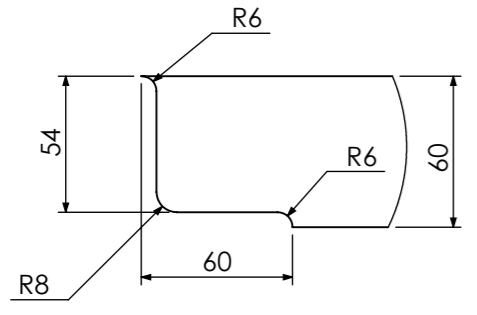
B



ANG.PROJ.:	 گروه صنایع سیمان کرمان 			
TELORANCE:	<small>ISO 2768-1 (Tolerance Class m) ISO 2768-2 (Tolerance Class k) ISO 13920 (Tolerance Class A)</small>			
UNIT: mm, kg	(سهامی عام)			
Document Type: Part	NAME	SIGNATURE	DATE	TITLE: Bag filter clean gas chamber body L angel 60x60(01-02) Bag filter clean gas chamber body plate(13-14)
QTY: ***	DRAWN M.H.Izadi			PART NO.: BF-01-03-01-06-(01-02-03-04)
Revision:	CHECKED M.S.Arabnejad			Document ID: **
Revision Date:	APPROVED A.Anjomshoa			REF. Document ID:
Classification:	Material: --			Record ID:
	WEIGHT: 10.5 Kg		Scale: 1:20	Sheet: 42 of 61
				Size: A3



8 7 6 5 4 3 2 1

A

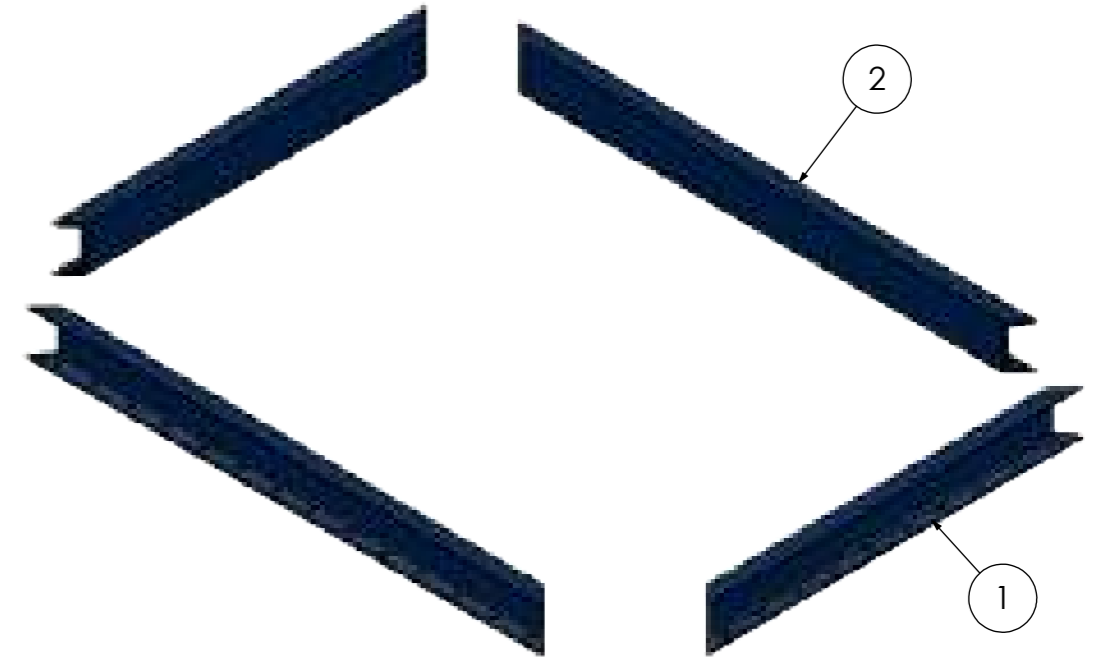
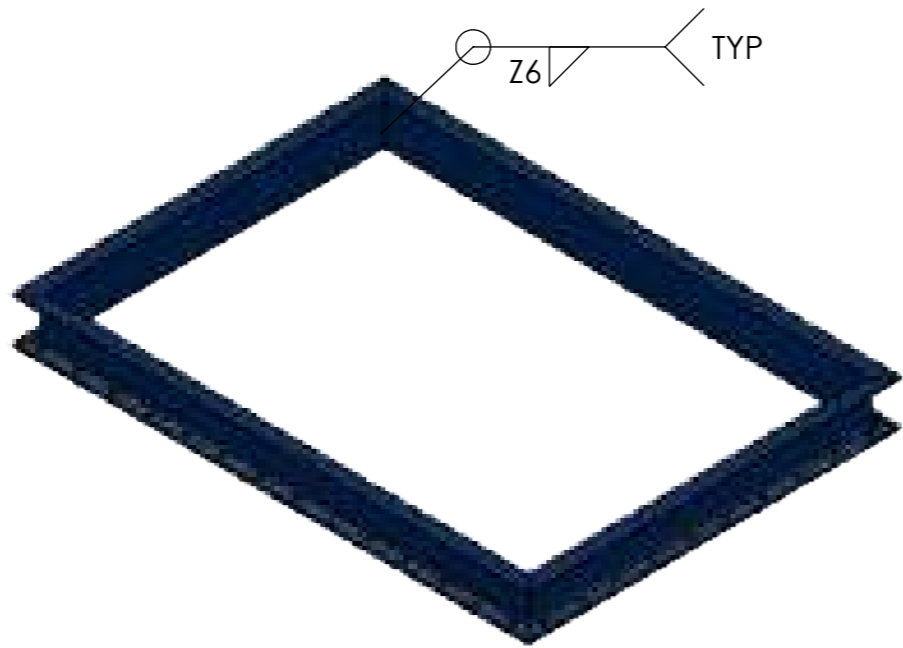
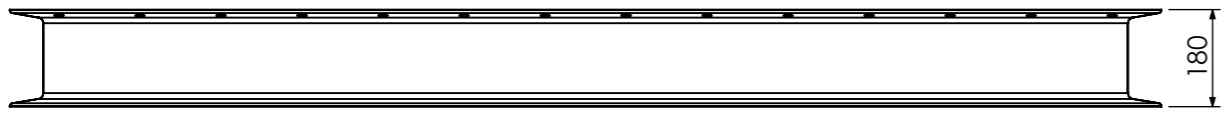
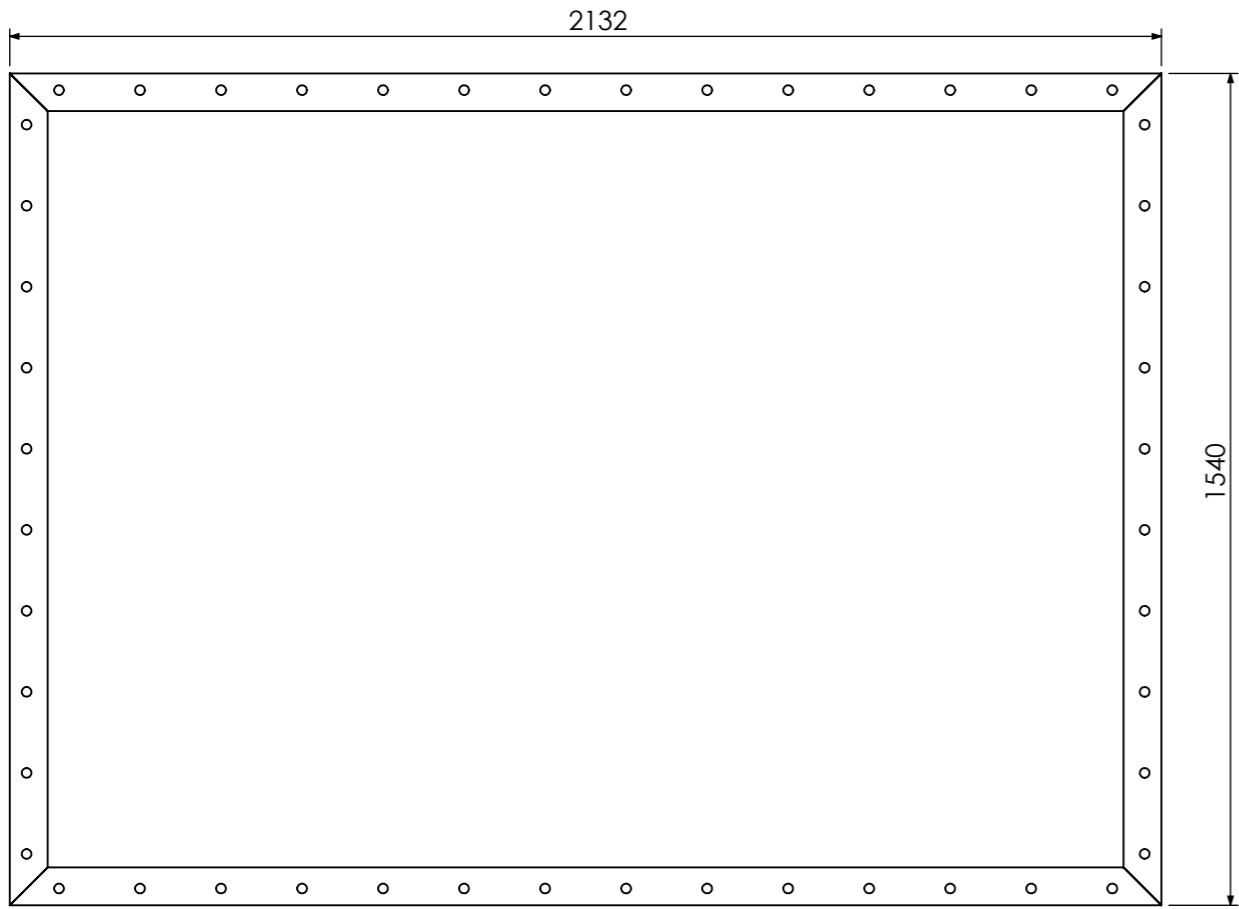
A



ITEM NO.	PART NUMBER	PART NAME	WEIGHT(KG)	MATERIAL	QTY.
1	BF-01-03-01-07-01	Bag filter clean gas chamber body UNP180.01	31.7	ST37	2
2	BF-01-03-01-07-02	Bag filter clean gas chamber body UNP180.02	44.8	ST37	2

ANG.PROJ.:	 گروه صنایع سیمان کرمان (سهامی عام)			
TELORANCE: ISO 2768-1 (Tolerance Class m) ISO 2768-2 (Tolerance Class k) ISO 13920 (Tolerance Class A)	UNIT: mm, kg			
Document Type: Assem	NAME	SIGNATURE	DATE	TITLE:
QTY.: ***	DRAWN: M.H.Izadi			Bag filter clean gas chamber body part.05
Revision:	CHECKED: M.S.Arabnejad			PART NO.: BF-01-03-01-07
Revision Date:	APPROVED: A.Anjomshoa			Document ID: **
Classification:	Material: --			REF. Document ID:
	WEIGHT: 152.9 Kg			Record ID:
				Scale: 1:20
				Sheet: 43 of 61
				Size: A3

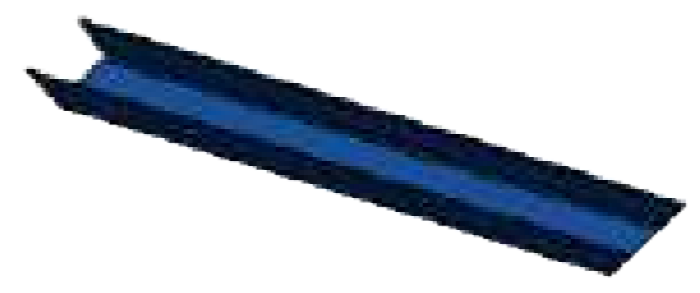
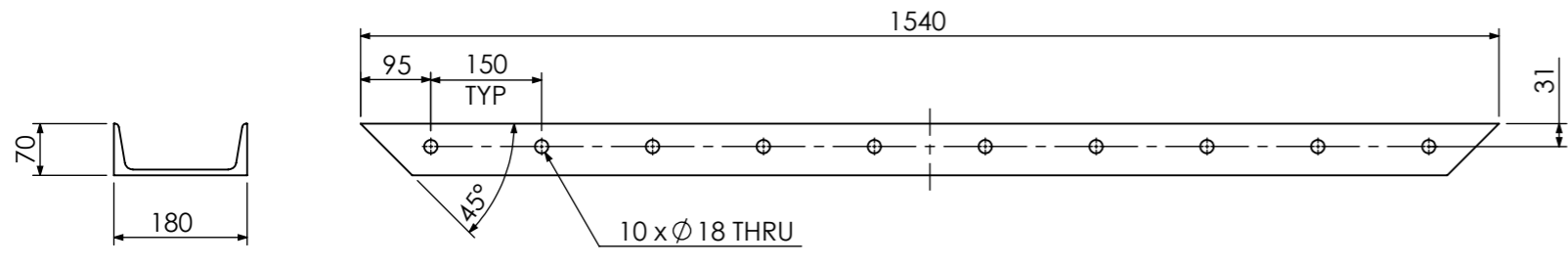

Bag filter clean gas chamber body UNP180.01
BF-01-03-01-07-01

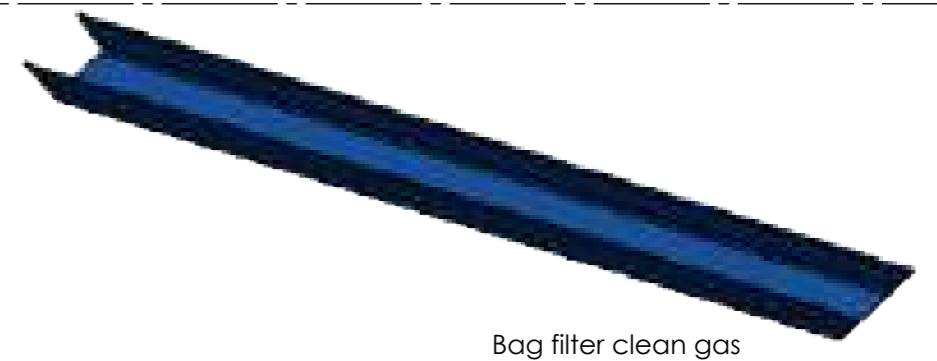
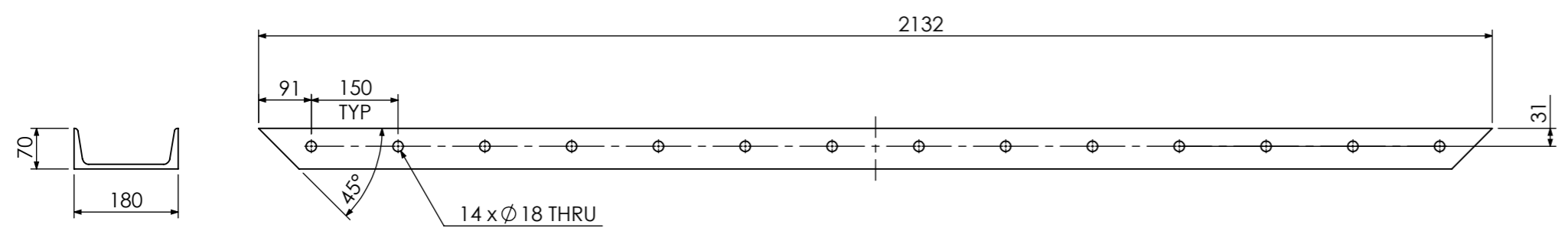

Bag filter clean gas chamber body UNP180.02
BF-01-03-01-07-02

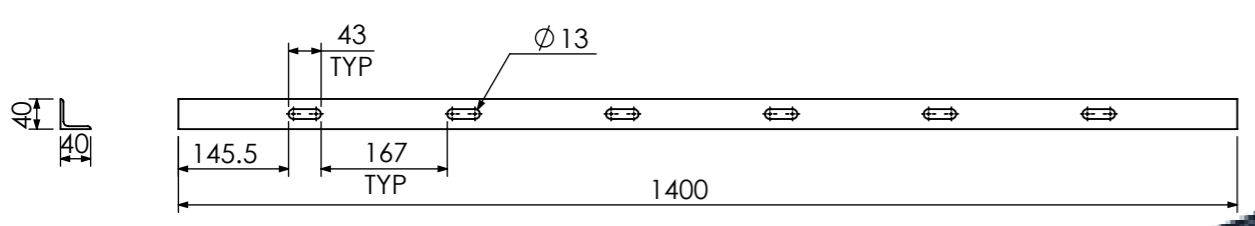

Bag filter clean gas chamber body L angel 40x40.01
BF-01-03-01-16

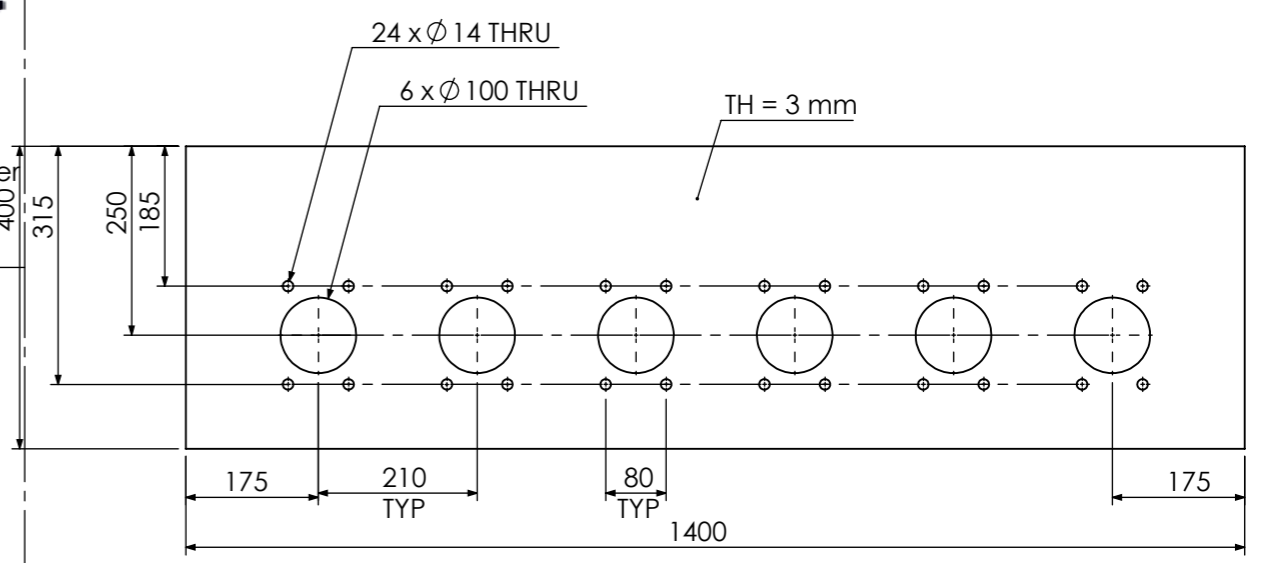

Bag filter clean gas chamber body plate.05
BF-01-03-01-13

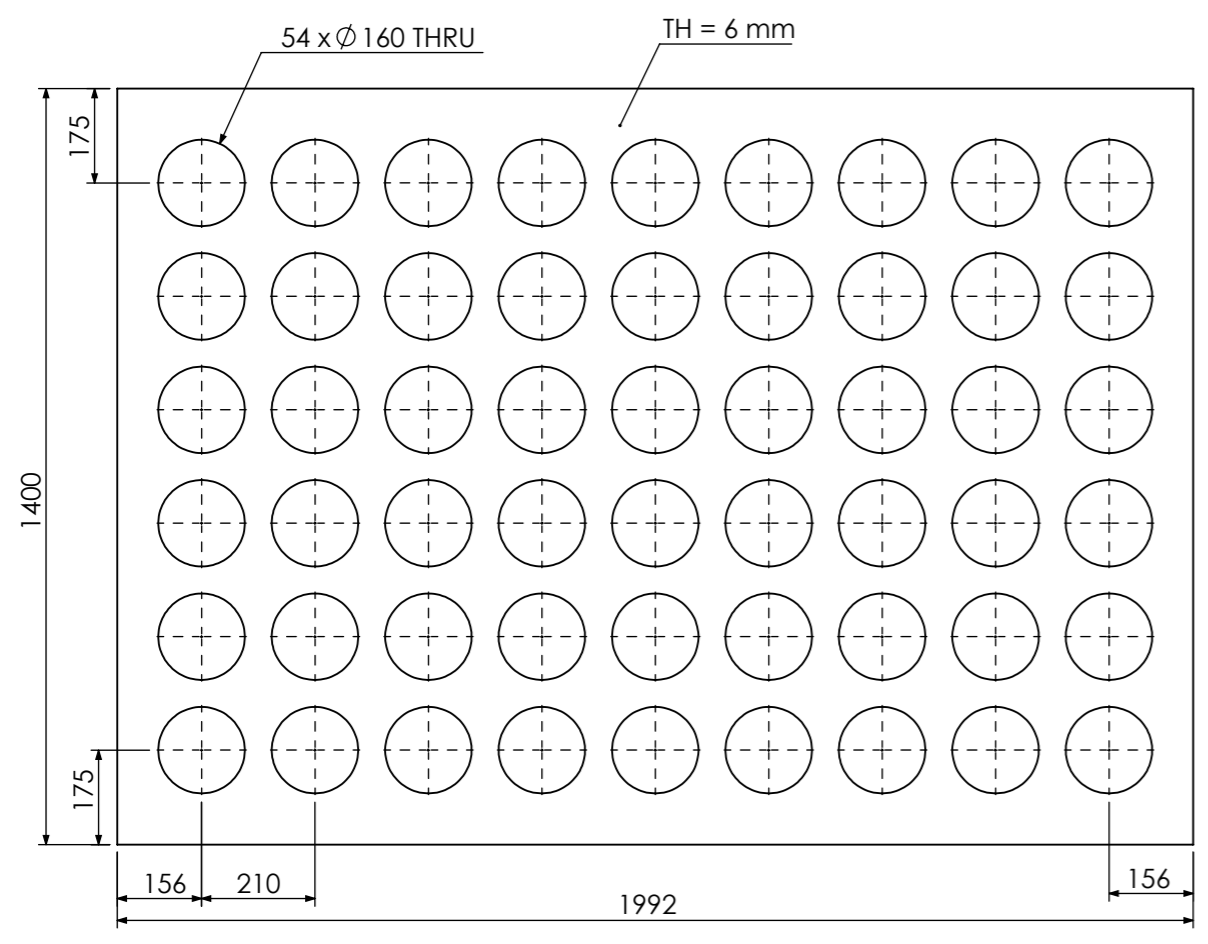

Bag filter clean gas chamber body plate.01
BF-01-03-01-09

ANG.PROJ.:				
TOLERANCE:	ISO 2768-1 (Tolerance Class m) ISO 2768-2 (Tolerance Class k) ISO 13920 (Tolerance Class A)			
UNIT:	mm, kg			
Document Type:	Part	گروه صنایع سیمان کرمان (سهامی عام)		
QTY.:	***	NAME	SIGNATURE	DATE
Revision:		DRAWN: M.H.Izadi CHECKED: M.S.Arabnejad APPROVED: A.Anjomshoa		TITLE: Bag filter clean gas chamber body UNP180(01-02) Bag filter clean gas chamber body plate(01-05) Bag filter clean gas chamber body L angel 40x40.01
Revision Date:		MATERIAL: -- WEIGHT: 31.7 Kg		PART NO.: BF-01-03-01-07(01-02) BF-01-03-01-07(09-13-16) Document ID: **
Classification:		REF. Document ID: Record ID:		Scale: 1:20 Sheet: 44 of 61 Size: A3

8 7 6 5 4 3 2 1

F
E
D
C
B
A

F
E
D
C
B
A

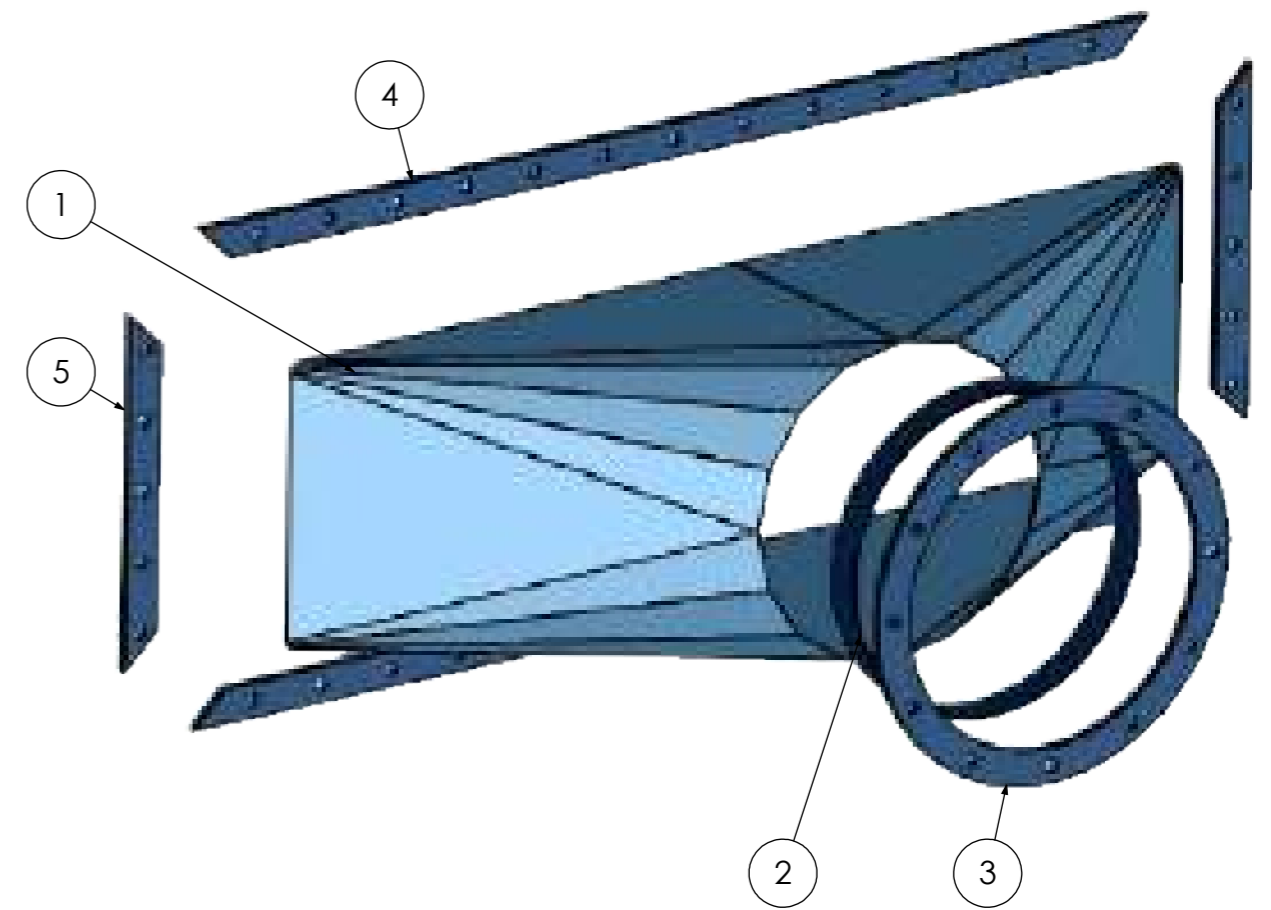
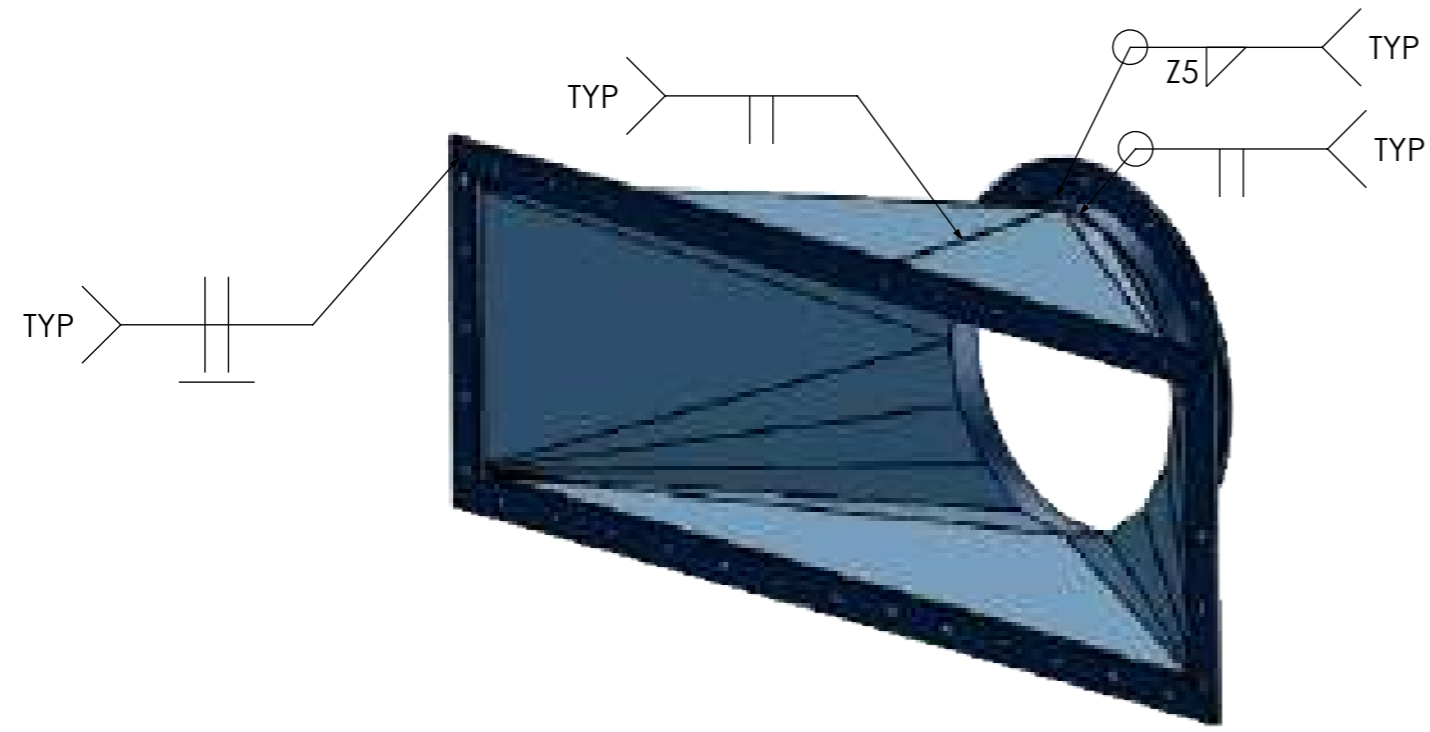
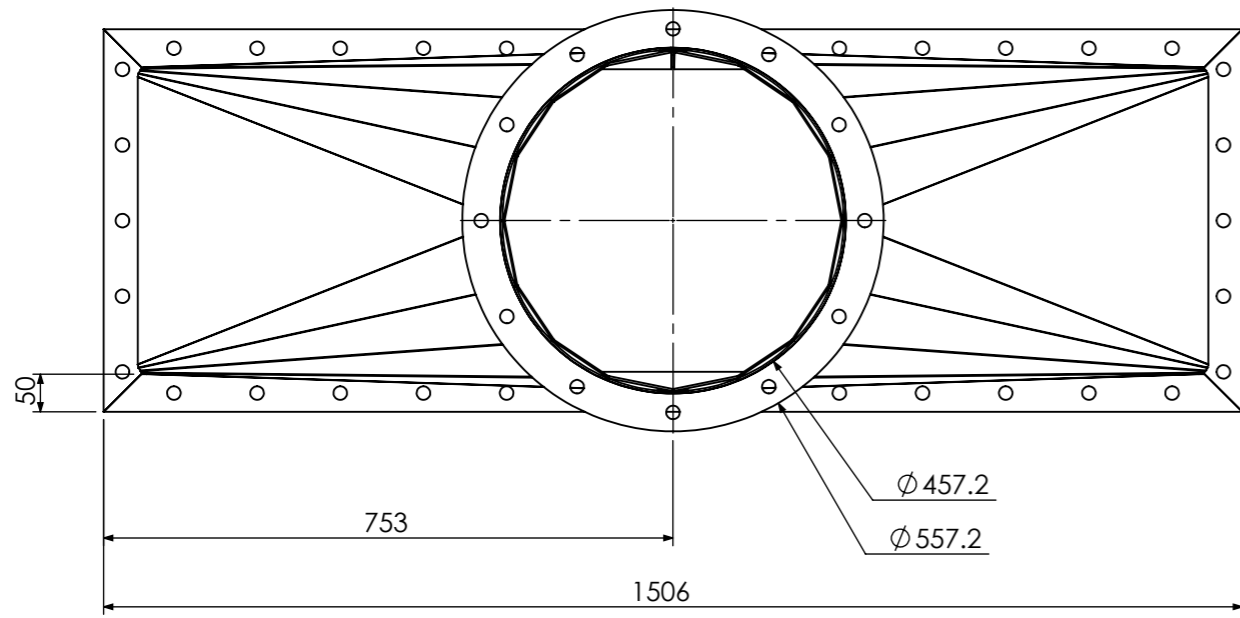
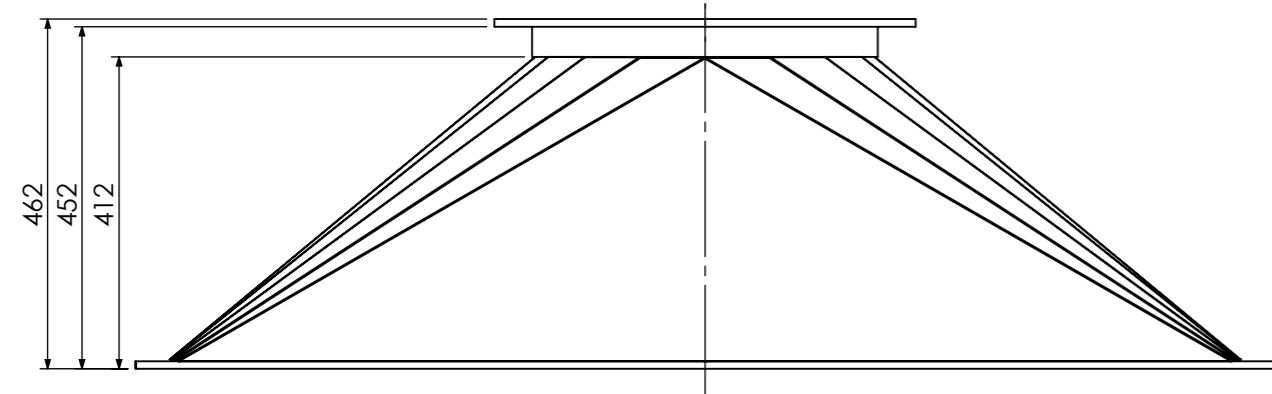

ITEM NO.	PART NUMBER	PART NAME	WEIGHT(KG)	MATERIAL	QTY.
1	BF-01-03-02-01	Bag filter clean gas chamber body plate.15	28.3	ST37	1
2	BF-01-03-02-02	Bag filter dust hopper pipe 18 in.02 (L=50 mm)	1.7	ST37	1
3	BF-01-03-02-03	Bag filter clean gas chamber body plate.16	6.0	ST37	1
4	BF-01-03-01-05-01	Bag filter clean gas chamber body plate.11	5.5	ST37	2
5	BF-01-03-01-05-02	Bag filter clean gas chamber body plate.12	1.7	ST37	2

ANG.PROJ.:

TELORANCE: ISO 2768-1 (Tolerance Class m)
ISO 2768-2 (Tolerance Class k)
ISO 13920 (Tolerance Class A)

UNIT: mm, kg

Document Type: **Assem**

QTY.: ***

Revision:

Revision Date:

Classification:

NAME: M.H.Izadi
SIGNATURE:
DATE:
TITLE: **Bag filter clean gas outlet**

PART NO.: BF-01-03-02

Document ID: **

REF. Document ID:

Record ID:

WEIGHT: 50.3 Kg

Scale: 1:10

Sheet: 45 of 61

Size: A3

گروه صنایع سیمان کرمان (سهامی عام)

گارانتی

سازمان صنایع سیمان کرمان

8 7 6 5 4 3 2 1

8 7 6 5 4 3 2 1

F

F

E

E

D

D

C

C

B

B

A

A

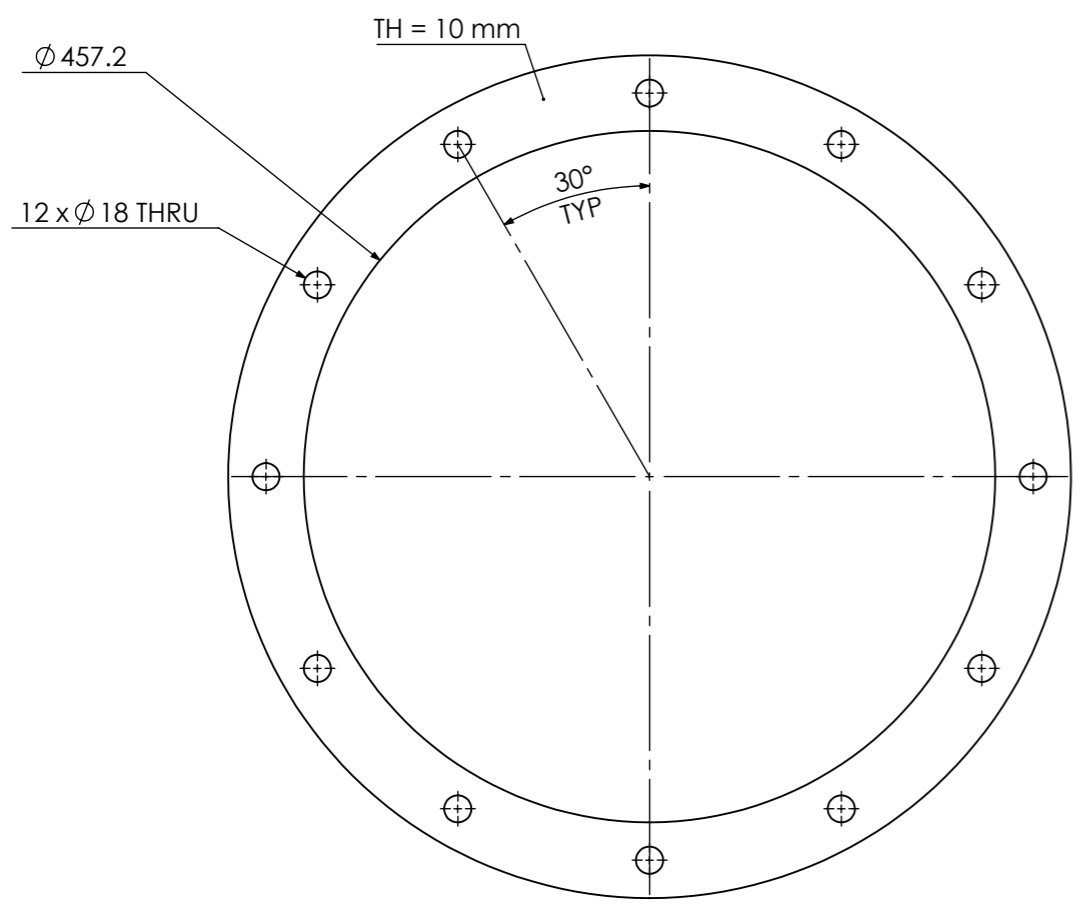
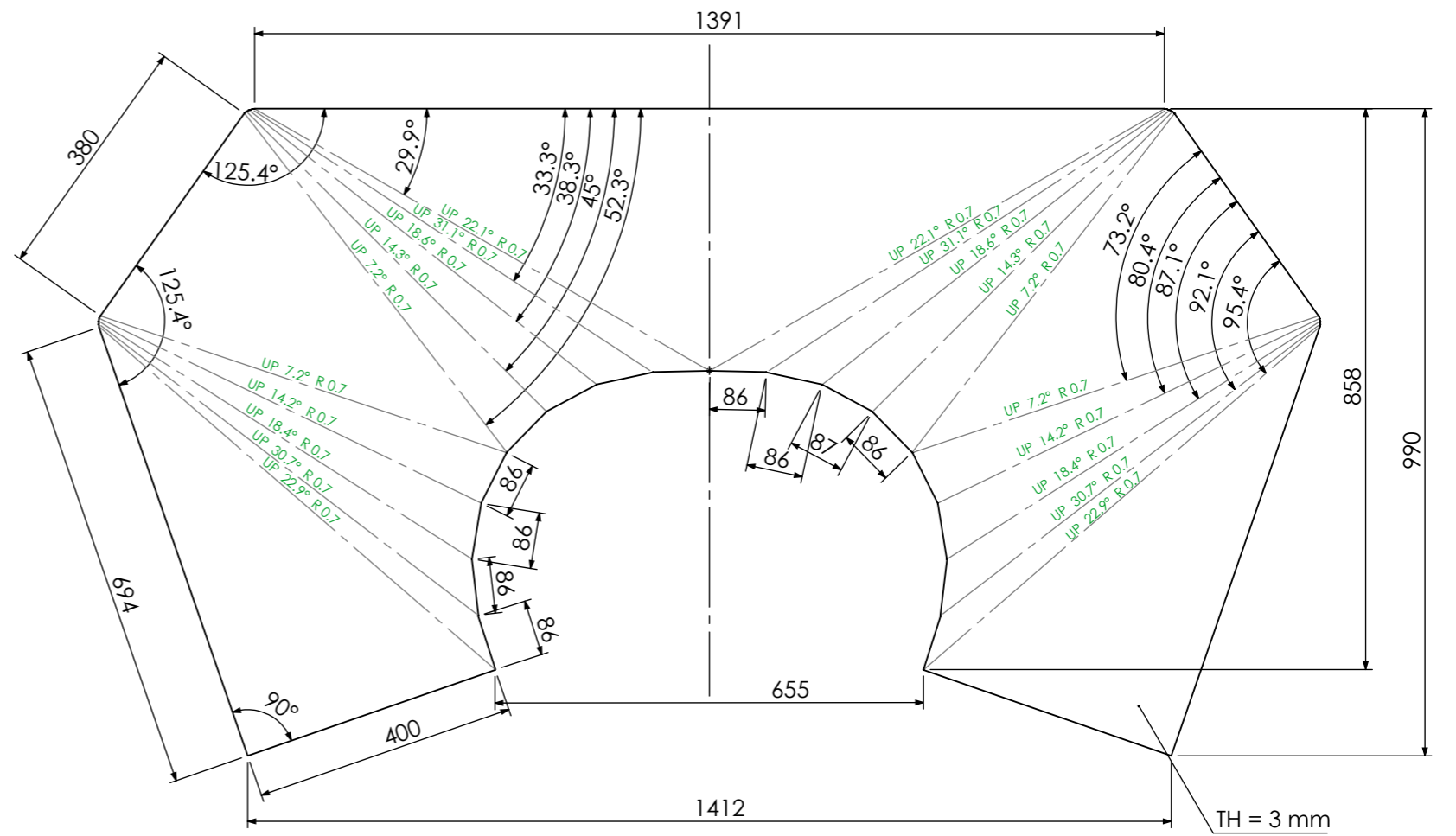
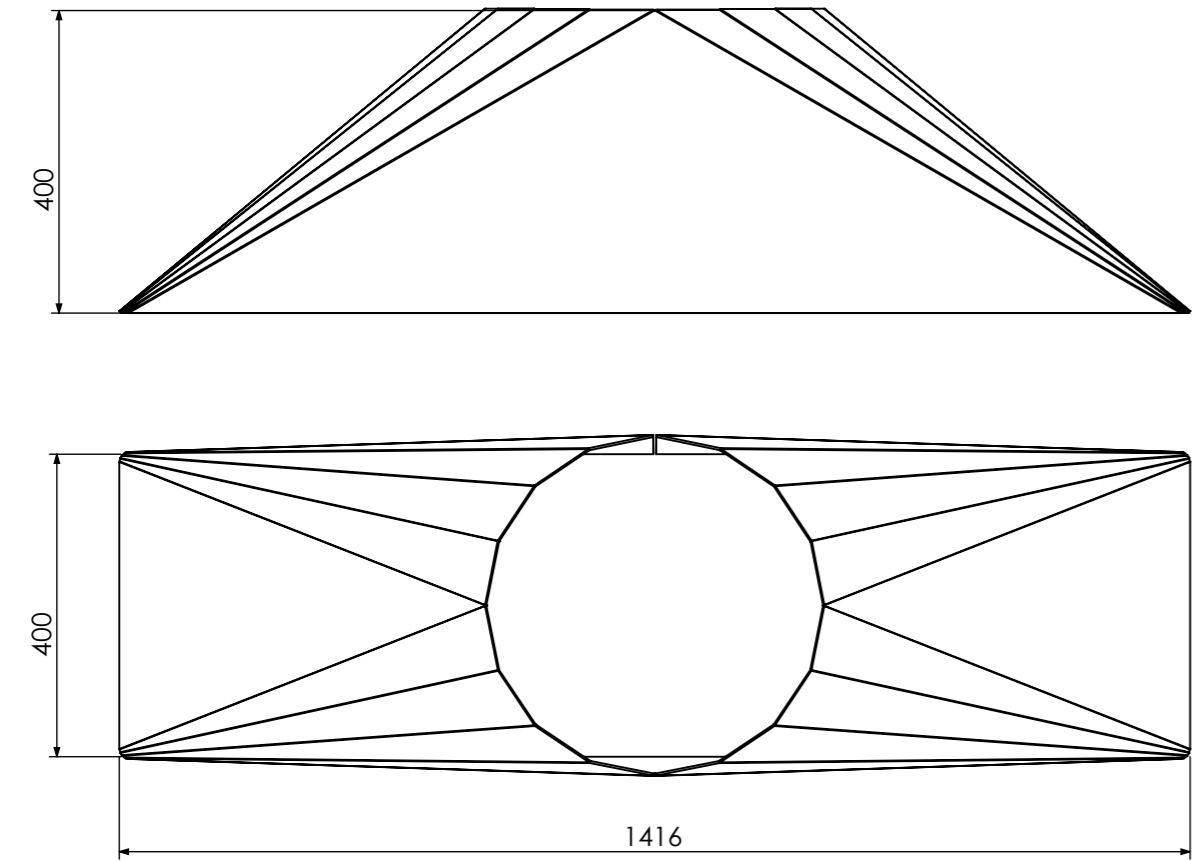

Bag filter clean gas chamber body plate.16
BF-01-03-02-03

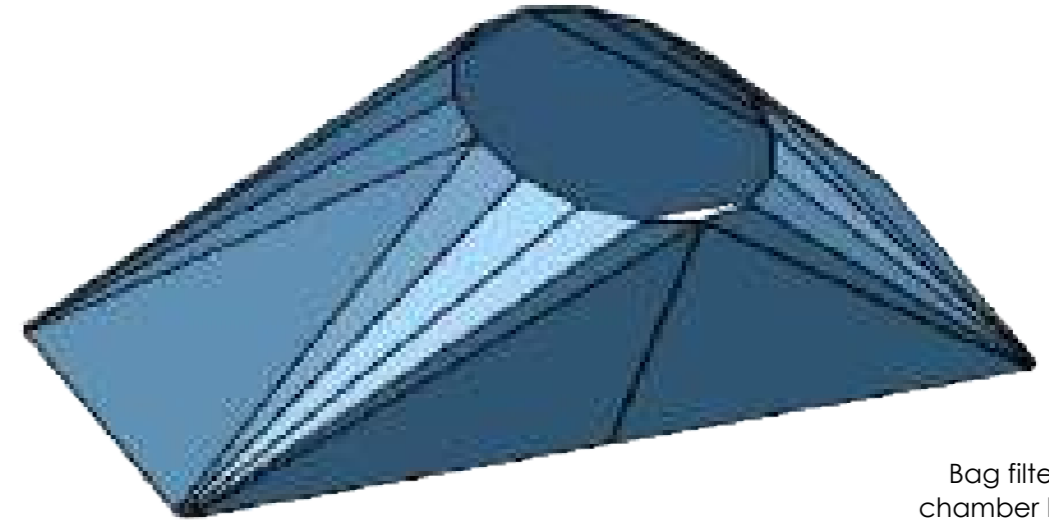

Bag filter clean gas chamber body plate.15
BF-01-03-02-01

ANG.PROJ.:	گروه صنایع سیمان کرمان (سهامی عام)			
TOLERANCE: ISO 2768-1 (Tolerance Class m) ISO 2768-2 (Tolerance Class k) ISO 13920 (Tolerance Class A)				
UNIT: mm, kg				
Document Type: Part	NAME	SIGNATURE	DATE	TITLE:
	DRAWN	M.H.Izadi		Bag filter clean gas chamber body plate(15-16)
	CHECKED	M.S.Arabnejad		PART NO.: BF-01-03-02-(01-03)
QTY.: ***	APPROVED	A.Anjomshoa		Document ID: **
Revision:				REF. Document ID:
Revision Date:	Material: --			Record ID:
Classification:	WEIGHT: 28.3 Kg	Scale: 1:10		Sheet: 46 of 61
				Size: A3

8 7 6 5 4 3 2 1

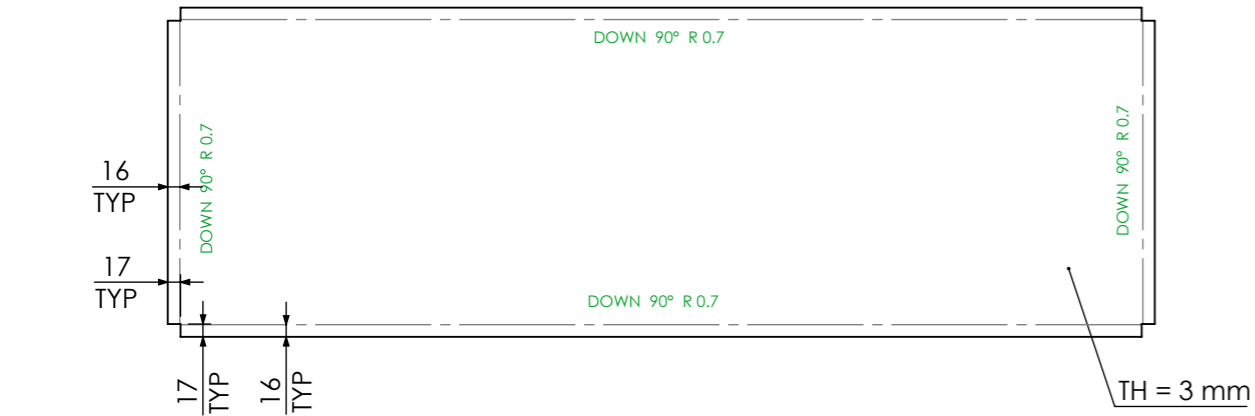
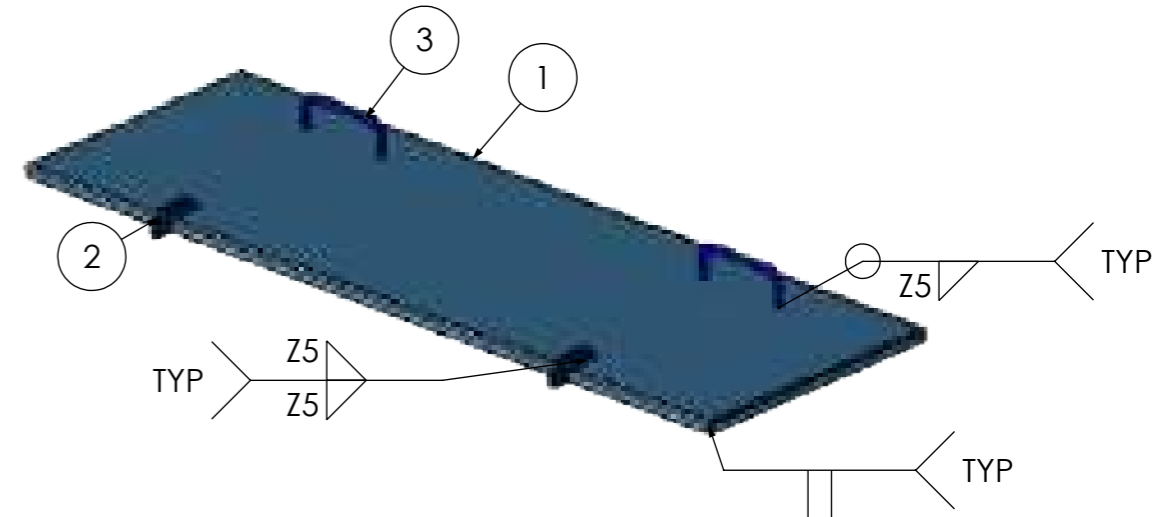
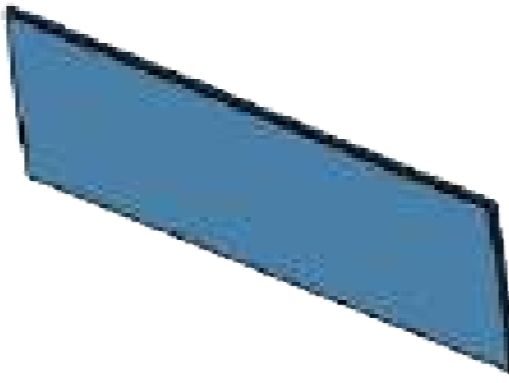
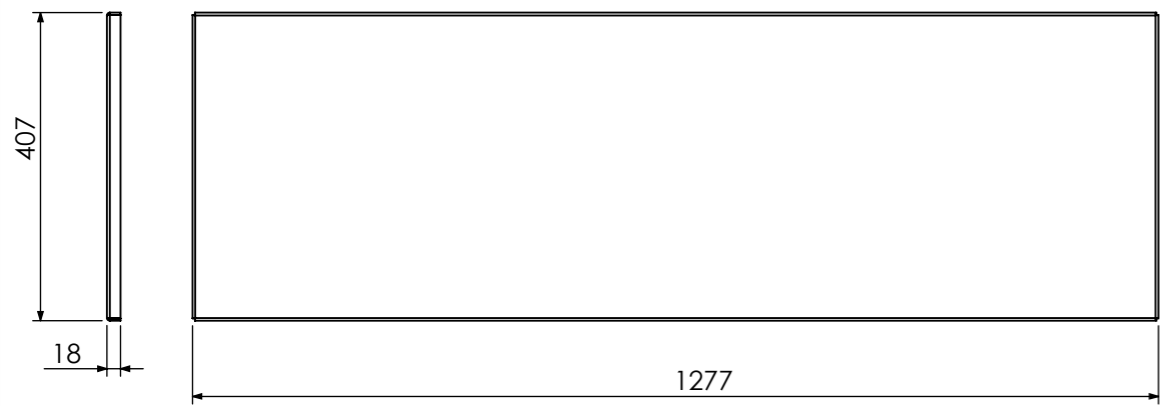
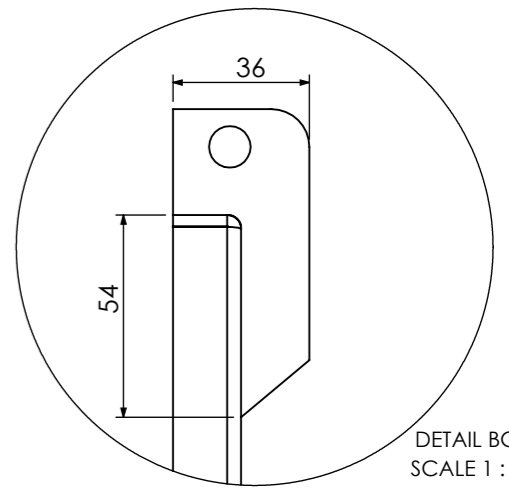
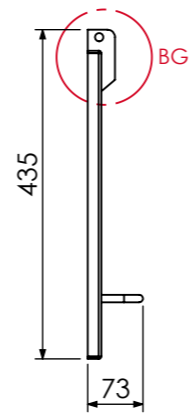
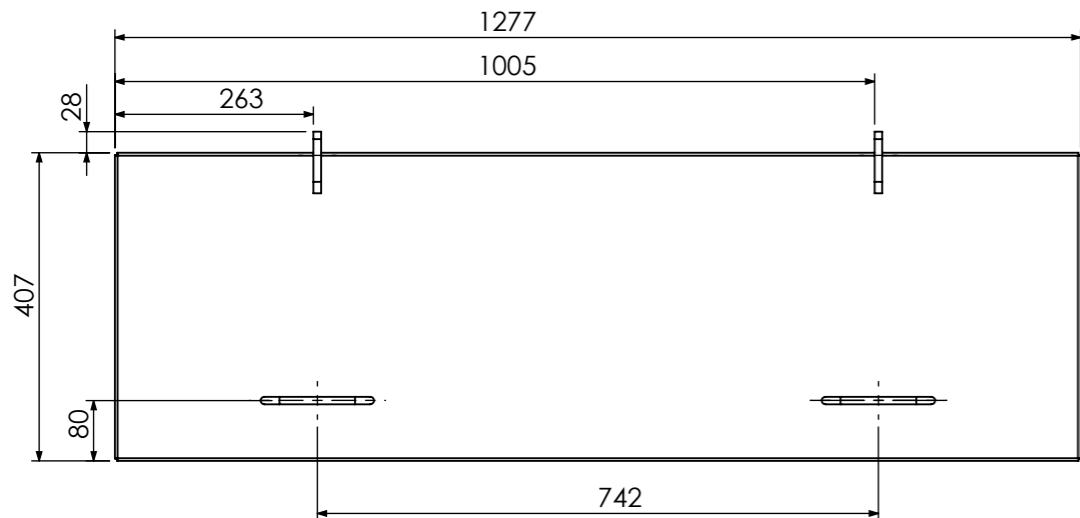

Bag filter clean gas chamber body plate.17
BF-01-03-03-01

ITEM NO.	PART NUMBER	PART NAME	WEIGHT(KG)	MATERIAL	QTY.
1	BF-01-03-03-01	Bag filter clean gas chamber body plate.17	13.4	ST37	1
2	BF-01-03-03-02	Bag filter clean gas chamber body plate.18	0.1	ST37	2
3	BF-01-02-03-03	Bag filter dust hopper window handle.01	0.1	ST37	2

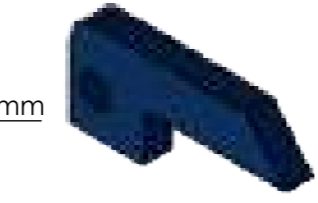
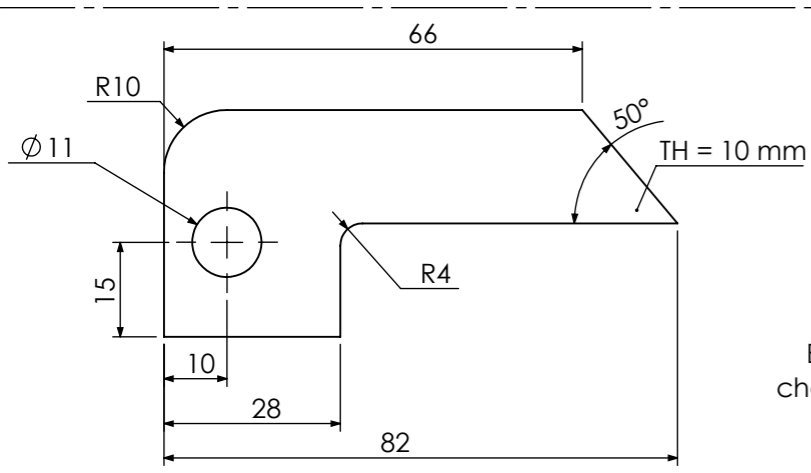

Bag filter clean gas chamber body plate.18
BF-01-03-03-02

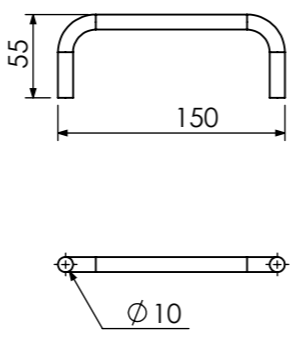

Bag filter dust hopper window handle.01
BF-01-02-03-03

ANG.PROJ.:

ISO 2768-1 (Tolerance Class m)
ISO 2768-2 (Tolerance Class k)
ISO 13920 (Tolerance Class A)

UNIT: mm, kg

Document Type: **Assem**

QTY.: ***

Revision:

Revision Date:

Classification:

گروه صنایع سیمان کرمان
(سهامی عام)

NAME: M.H.Izadi

SIGNATURE: _____

DATE: _____

TITLE: Bag filter clean gas chamber window.01
Bag filter clean gas chamber body plate(17-18)

CHECKED: M.S.Arabnejad

APPROVED: A.Anjomshoa

Material: --

WEIGHT: 13.8 Kg

PART NO.: BF-01-03-03
BF-01-03-03-(01-02)

Document ID: **

REF. Document ID:

Record ID:

Scale: 1:20

Sheet: 47 of 61

Size: A3

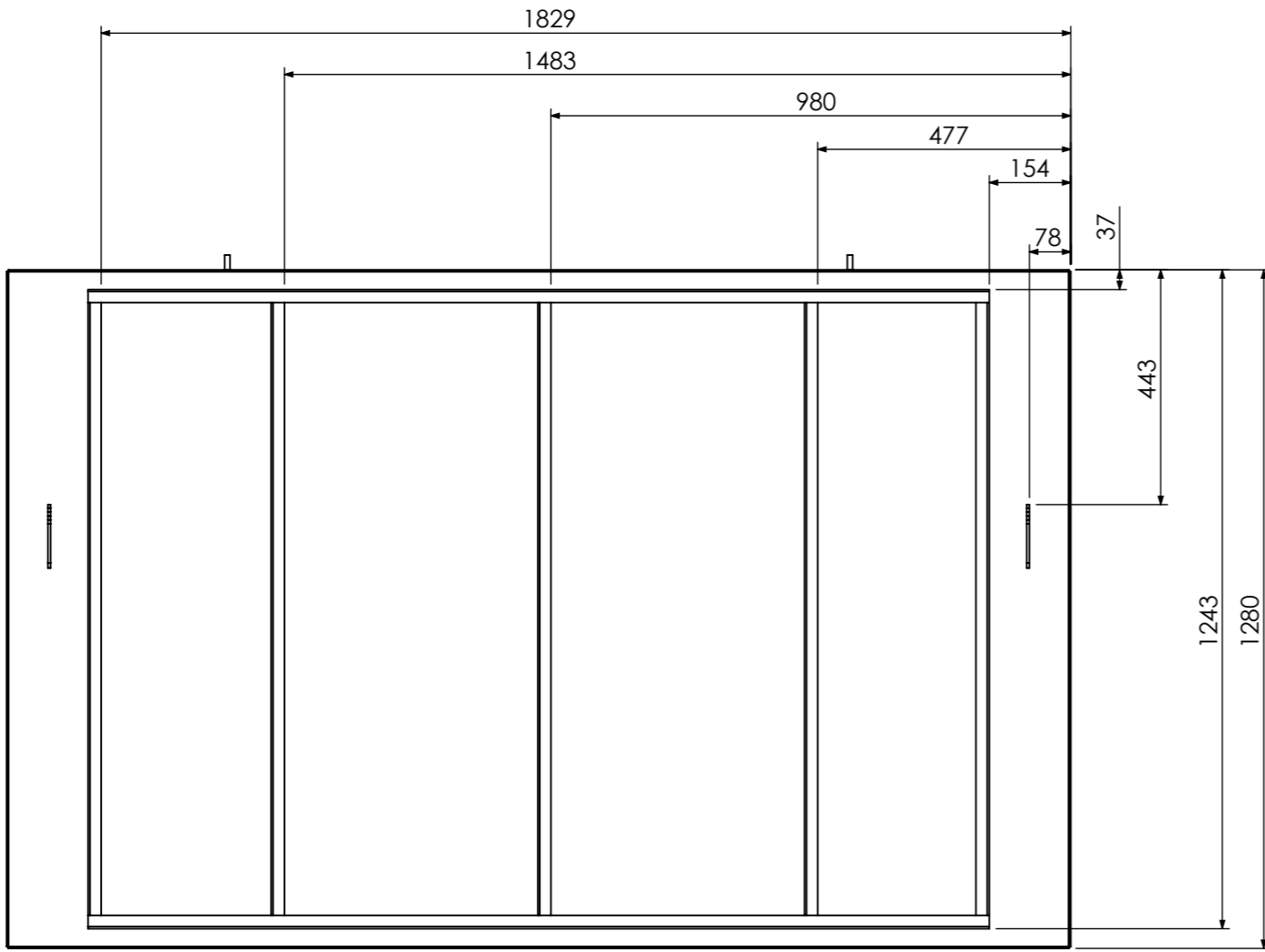
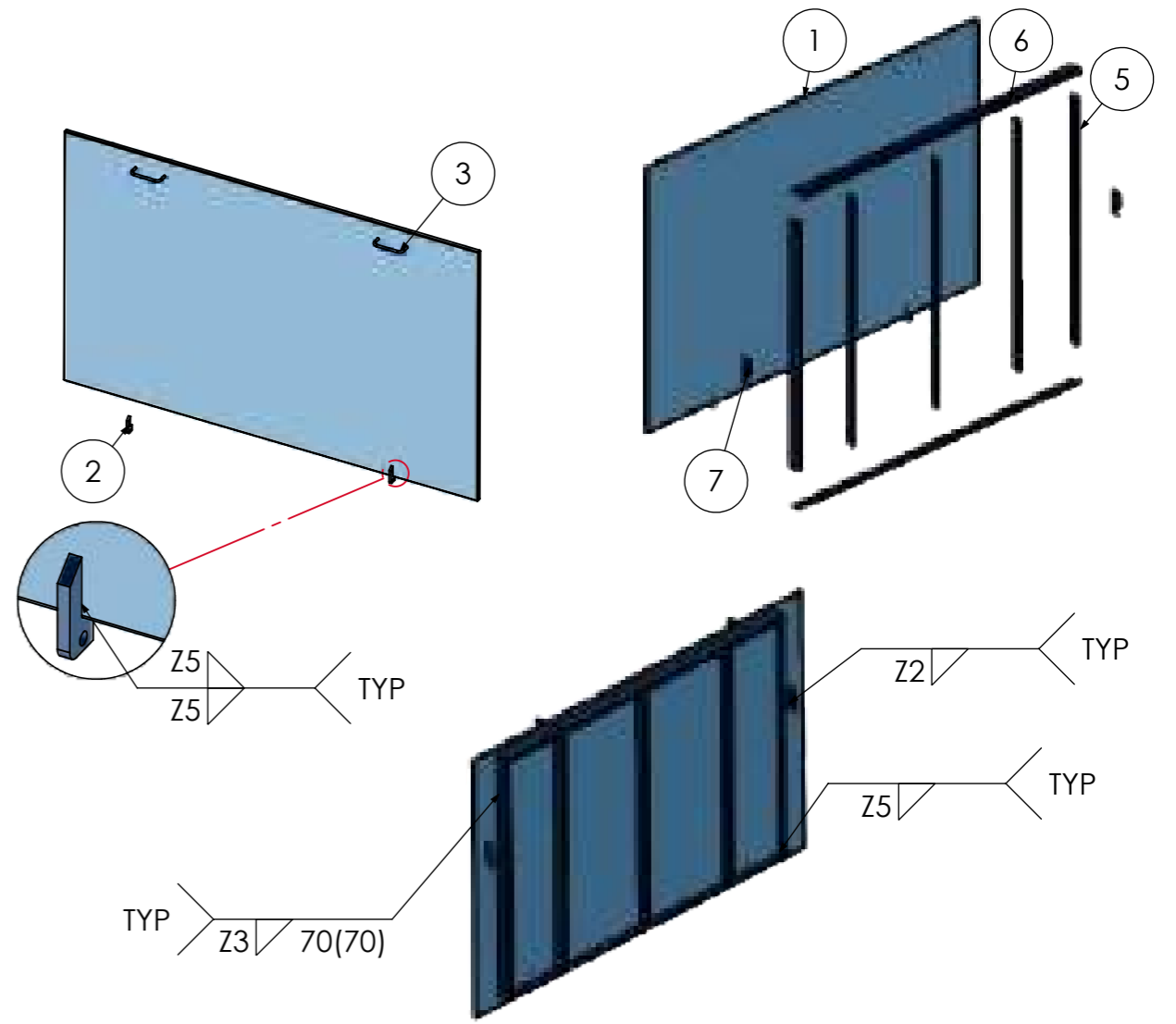
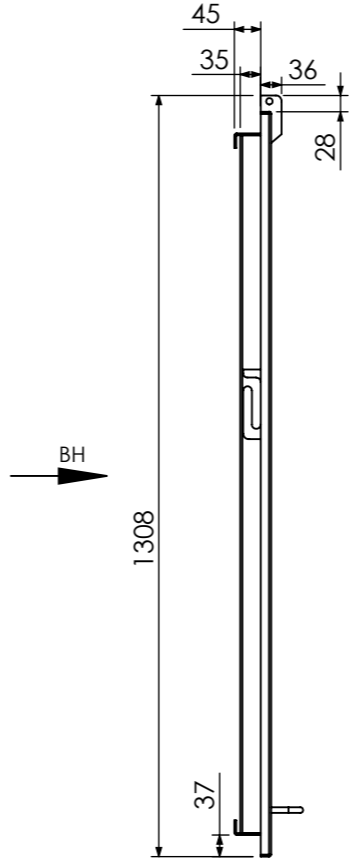
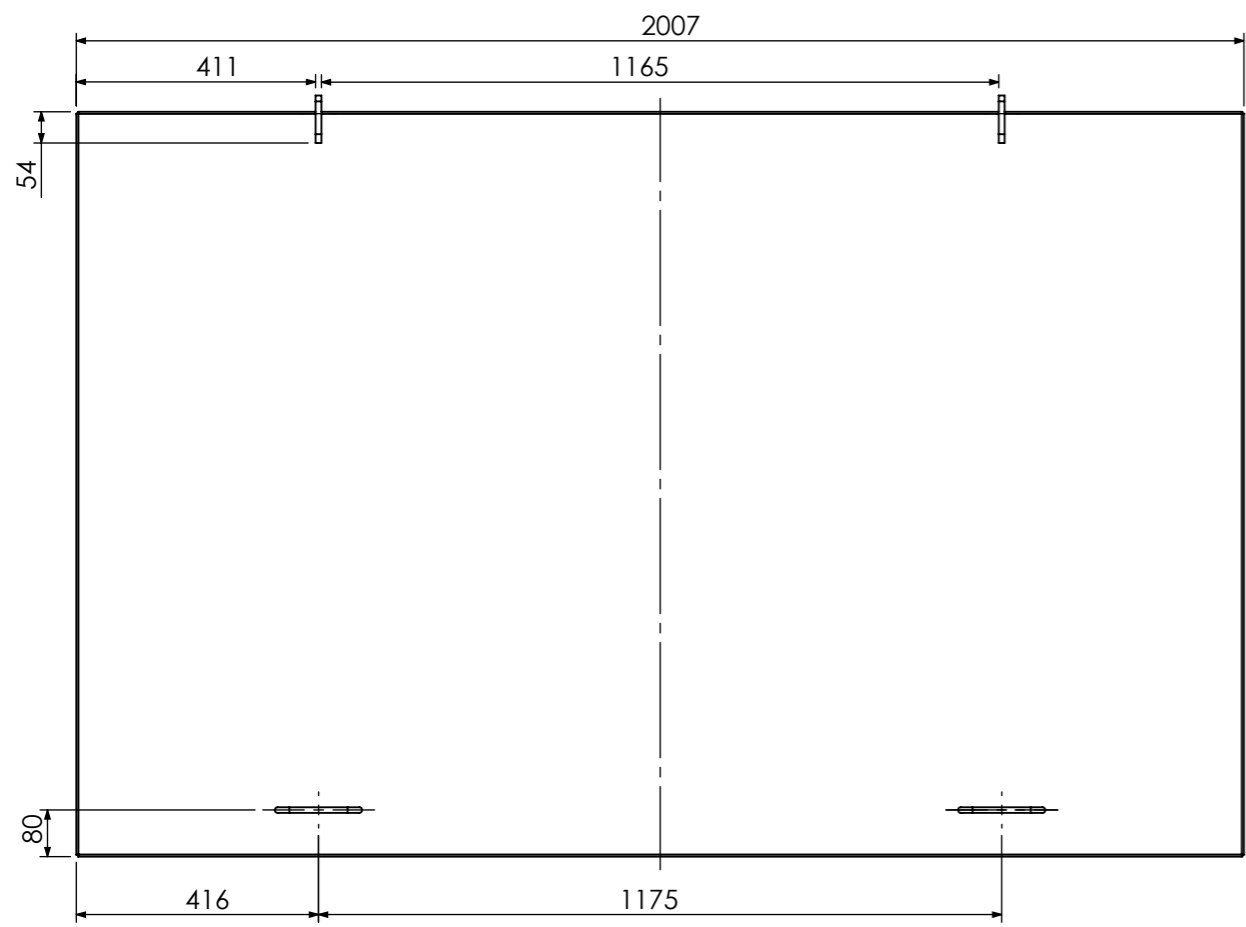

VIEW BH

ITEM NO.	PART NUMBER	PART NAME	WEIGHT(KG)	MATERIAL	QTY.
1	BF-01-03-04-01	Bag filter clean gas chamber body plate.19	62.7	ST37	1
2	BF-01-03-03-02	Bag filter clean gas chamber body plate.18	0.1	ST37	2
3	BF-01-02-03-03	Bag filter dust hopper window handle.01	0.1	ST37	2
5	BF-01-03-04-02	Bag filter clean gas chamber body plate.20	2.0	ST37	5
6	BF-01-03-04-03	Bag filter clean gas chamber body plate.21	3.2	ST37	2
7	BF-01-03-04-04	Bag filter clean gas chamber body plate.22	0.1	ST37	2

ANG.PROJ.:

TELERANCE: ISO 2768-1 (Tolerance Class m) ISO 2768-2 (Tolerance Class k) ISO 13920 (Tolerance Class A)

UNIT: mm, kg

Document Type: **Assem**

QTY.: ***

Revision:

Revision Date:

Classification:

WEIGHT: 80.0 Kg

گروه صنایع سیمان کرمان
(سهامی عام)

NAME	SIGNATURE	DATE	TITLE:
DRAWN: M.H.Izadi			Bag filter clean gas chamber window.02
CHECKED: M.S.Arabnejad			PART NO.: BF-01-03-04
APPROVED: A.Anjomshoa			Document ID: **
			REF. Document ID:
			Record ID:
			Scale: 1:50
			Sheet: 48 of 61
			Size: A3

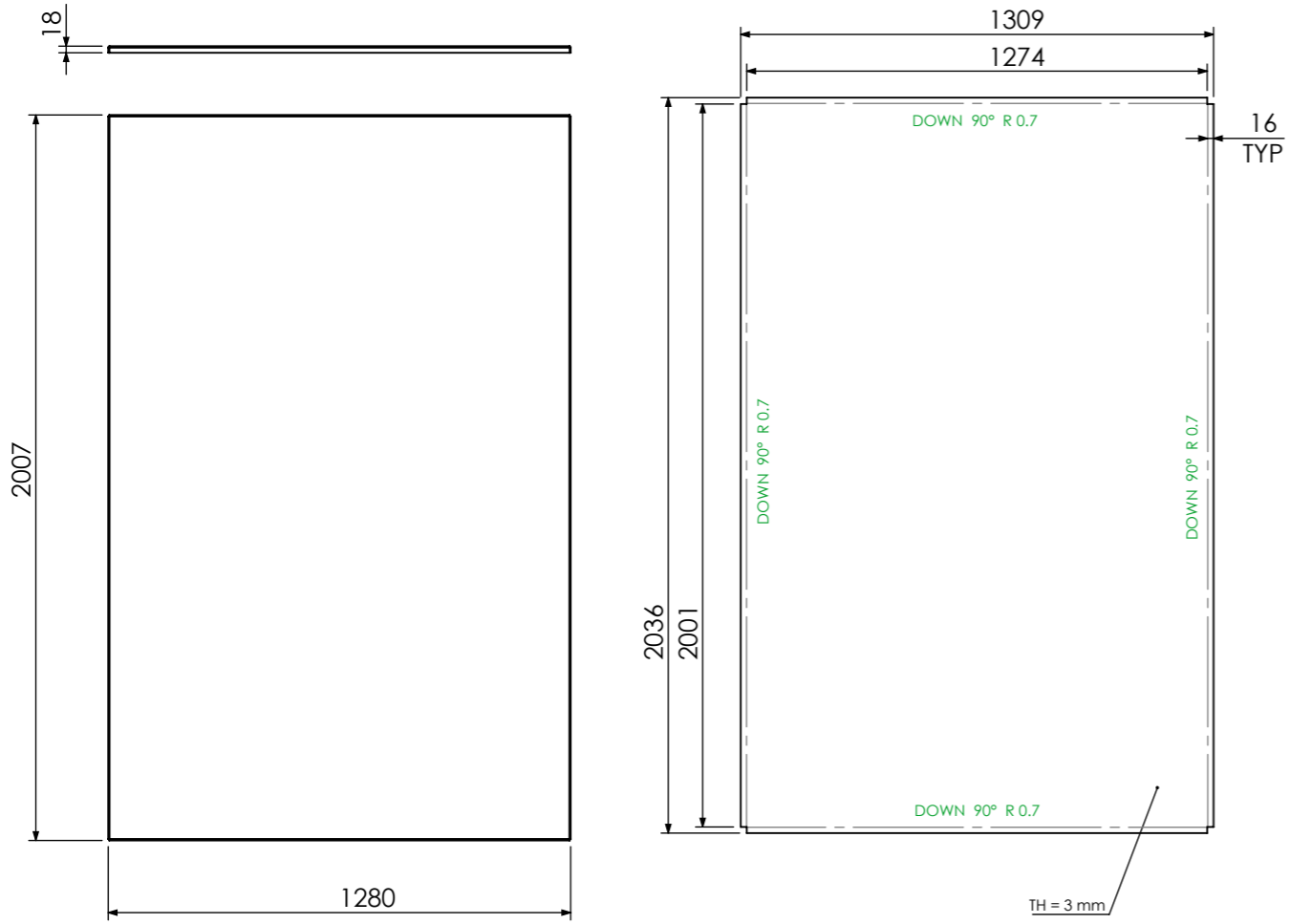

Bag filter clean gas chamber body plate.19
BF-01-03-04-01

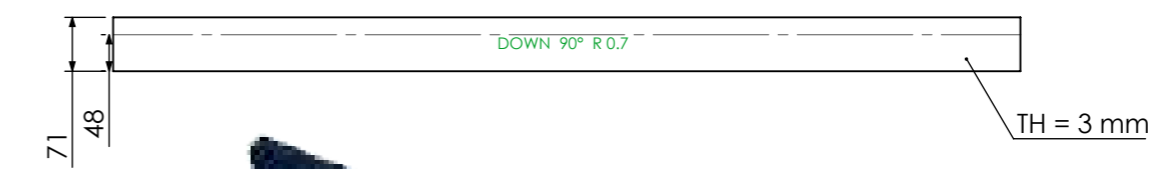
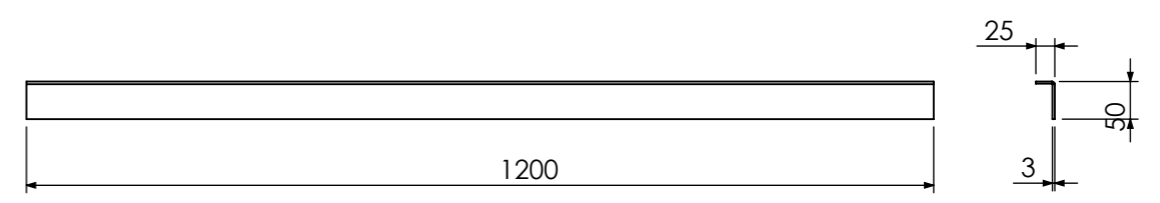

Bag filter clean gas chamber body plate.20
BF-01-03-04-02

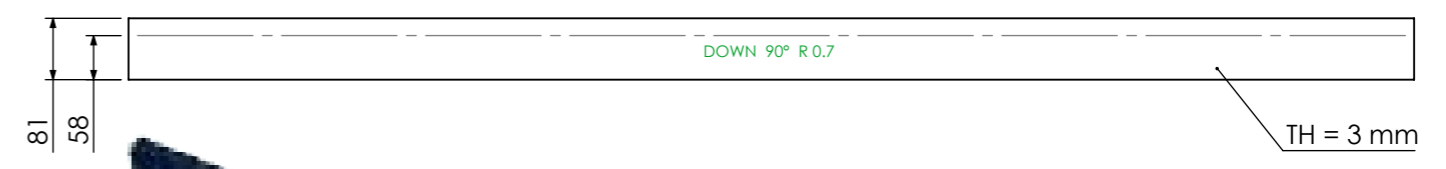
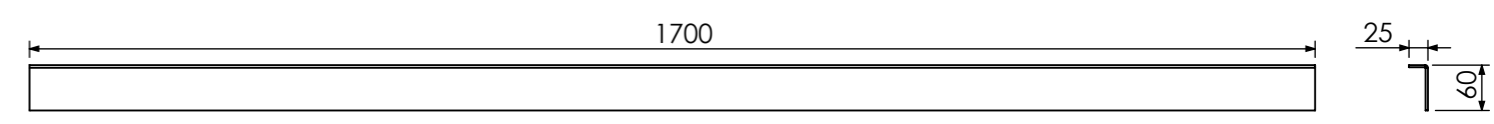

Bag filter clean gas chamber body plate.21
BF-01-03-04-03

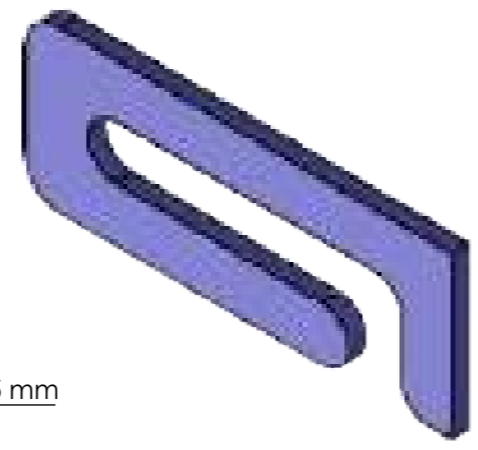
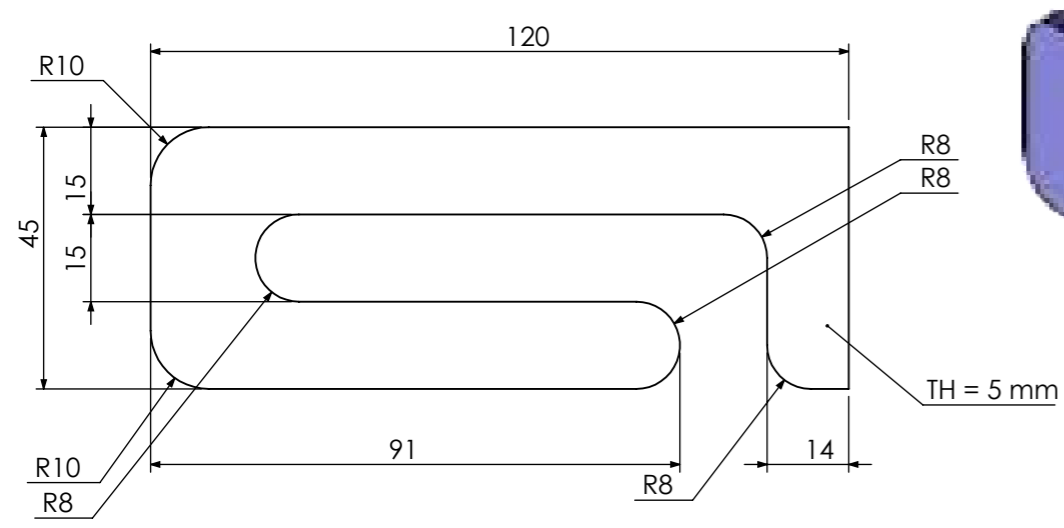

Bag filter clean gas chamber body plate.22
BF-01-03-04-04

ANG.PROJ.:					
TELORANCE:	ISO 2768-1 (Tolerance Class m) ISO 2768-2 (Tolerance Class k) ISO 13920 (Tolerance Class A)				گروه صنایع سیمان کرمان (سهامی عام)
UNIT: mm, kg					
Document Type: Part	NAME	SIGNATURE	DATE	TITLE:	
	DRAWN M.H.Izadi			Bag filter clean gas chamber body plate(19-20-21-22)	
QTY: ***	CHECKED M.S.Arabnejad			PART NO.: BF-01-03-04-(01-02-03-04)	
	APPROVED A.Anjomshoa			Document ID: **	
Revision:				REF. Document ID:	
Revision Date:	Material: --			Record ID:	
Classification:	WEIGHT: 62.7 Kg	Scale: 1:20		Sheet: 49 of 61	Size: A3

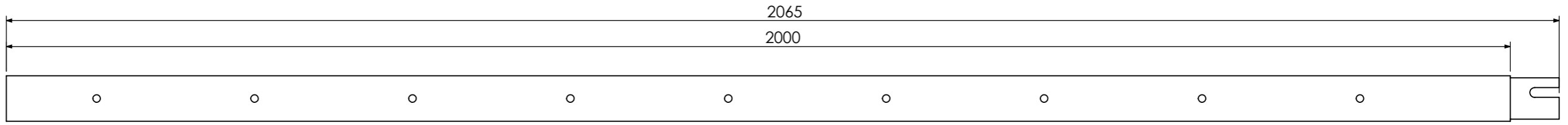
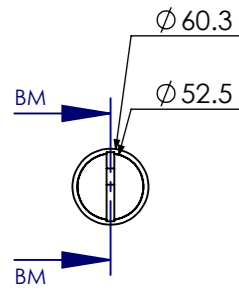

SECTION BM-BM
SCALE 1 : 6

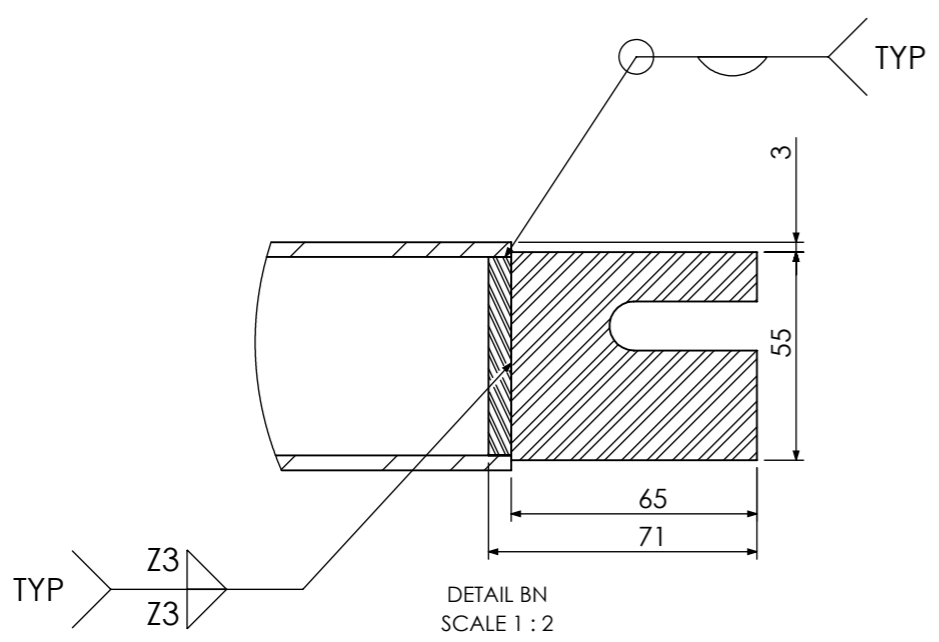
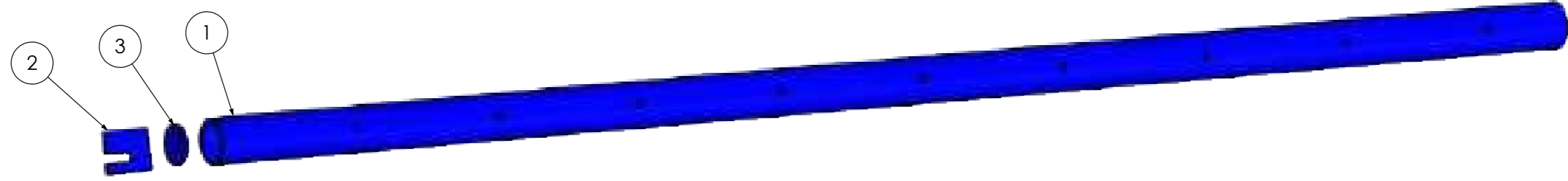

ITEM NO.	PART NUMBER	PART NAME	WEIGHT(KG)	MATERIAL	QTY.
1	BF-01-03-05-01	pipe-ANSI B36.19-2inx 3.91mm-welded Pipe	10784.05	ST37	1
2	BF-01-03-05-02	Bag filter clean gas chamber body plate.23	0.1	ST37	1
3	BF-01-03-05-03	Bag filter clean gas chamber body plate.24	0.1	ST37	1

ANG.PROJ.:		گروه صنایع سیمان کرمان (سهامی عام)			
TELORANCE:	<small>ISO 2768-1 (Tolerance Class m)</small> <small>ISO 2768-2 (Tolerance Class k)</small> <small>ISO 13920 (Tolerance Class A)</small>				
UNIT: mm, kg		NAME	SIGNATURE	DATE	TITLE:
Document Type: Assem		DRAWN: M.H.Izadi			Bag filter pressurized air distribution pipe.01
QTY.: ***		CHECKED: M.S.Arabnejad			PART NO.: BF-01-03-05
		APPROVED: A.Anjomshoa			Document ID: **
Revision:					REF. Document ID:
Revision Date:		Material: --			Record ID:
Classification:		WEIGHT: 11.0 Kg	Scale: 1:20	Sheet: 50 of 61	Size: A3

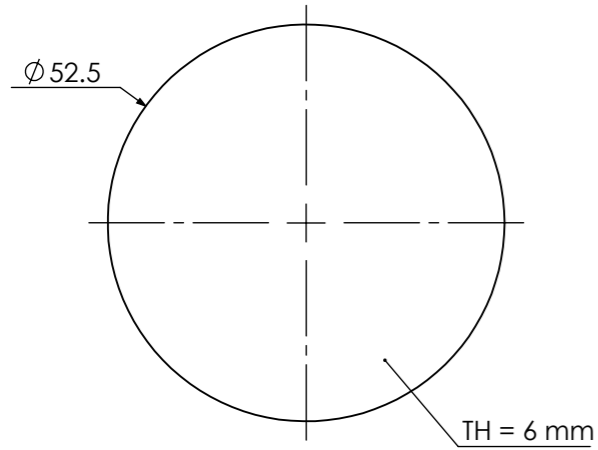
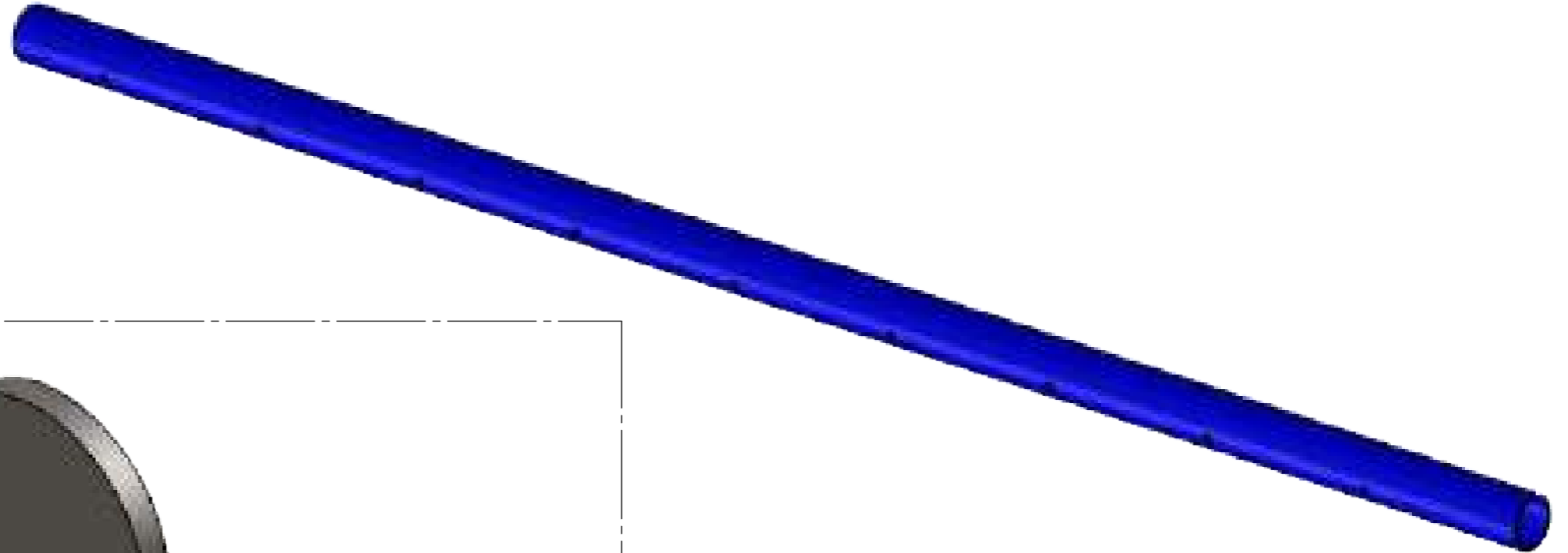
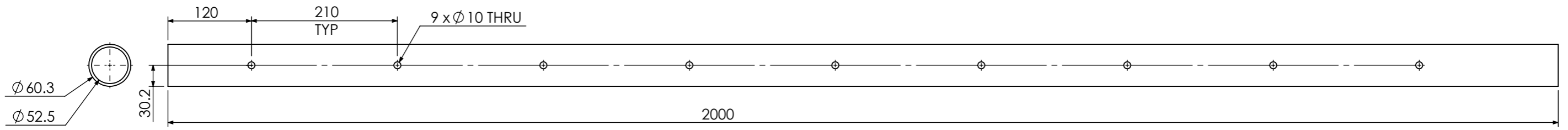

Bag filter clean gas chamber body plate.24
BF-01-03-05-03

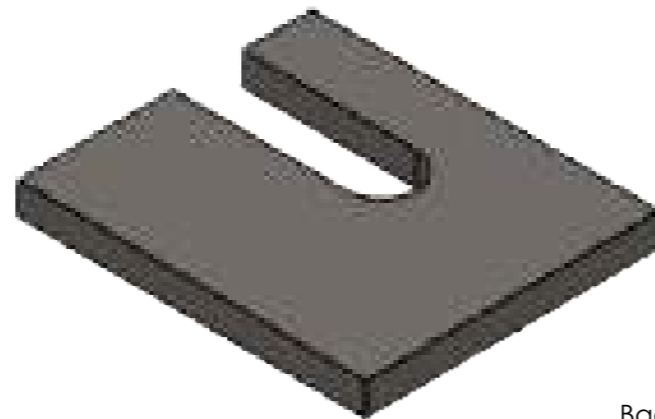
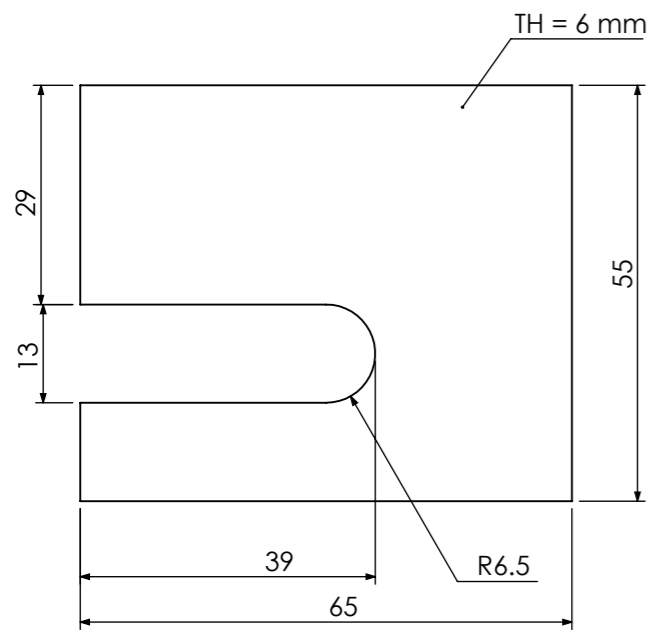

Bag filter clean gas chamber body plate.23
BF-01-03-05-02

pipe-ANSI B36.19-2inx
3.91mm-welded Pipe
BF-01-03-05-01

ANG.PROJ.:			گروه صنایع سیمان کرمان		
TELORANCE: ISO 2768-1 (Tolerance Class m) ISO 2768-2 (Tolerance Class k) ISO 13920 (Tolerance Class A)			(سهامی عام)		
UNIT: mm, kg					
Document Type: Part	NAME	SIGNATURE	DATE	TITLE: pipe-ANSI B36.19-2inx 3.91mm-welded Pipe Bag filter clean gas chamber body plate(23-24)	
	DRAWN	M.H.Izadi	1402/01/30	PART NO.: BF-01-03-05-(01-02-03)	
QTY.: 12	CHECKED	M.S.Arabnejad	1402/01/31	Document ID:	
	APPROVED	A.Anjomshoa	1402/02/04	REF. Document ID:	
Revision:					Record ID:
Revision Date:	Material: --				Scale: 1:20
Classification:	WEIGHT:10784.05 Kg		Sheet:51 of 61		Size: A3

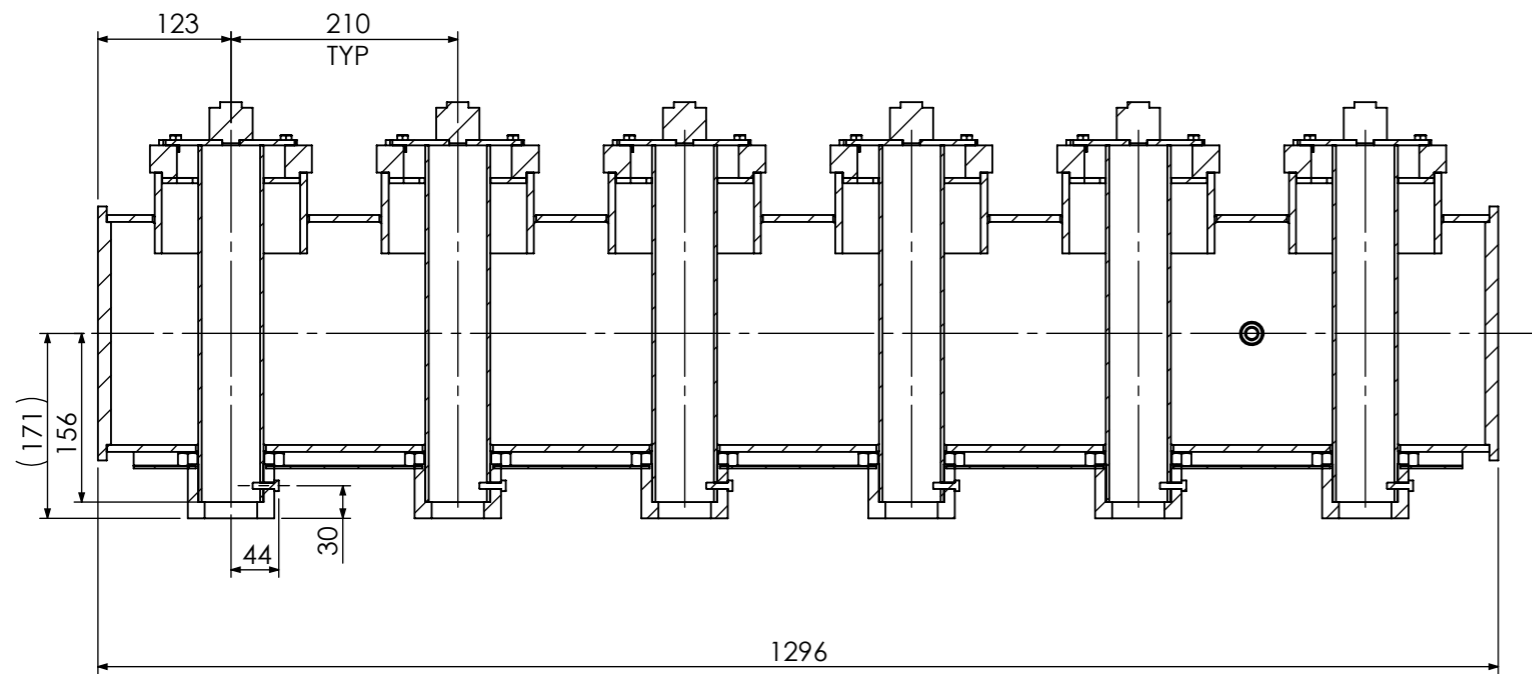
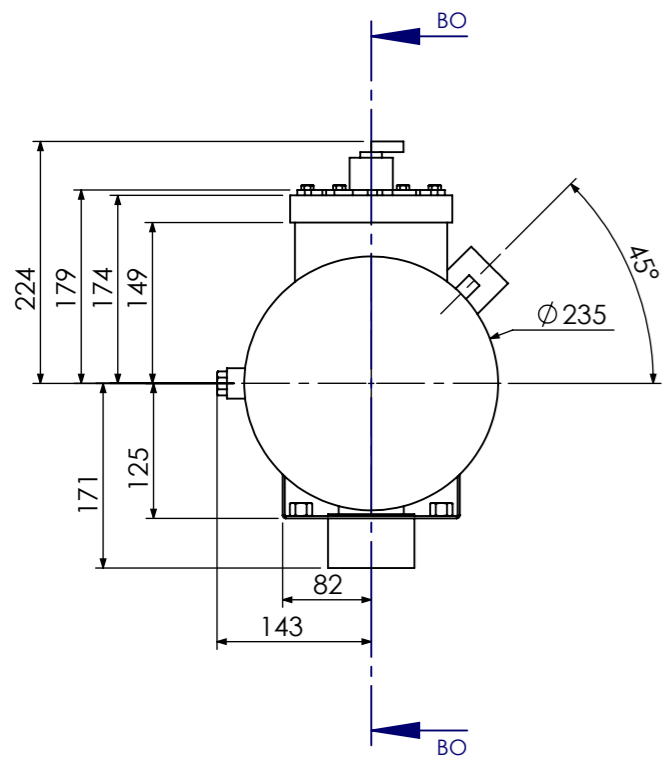

SECTION BO-BO
SCALE 1 : 7

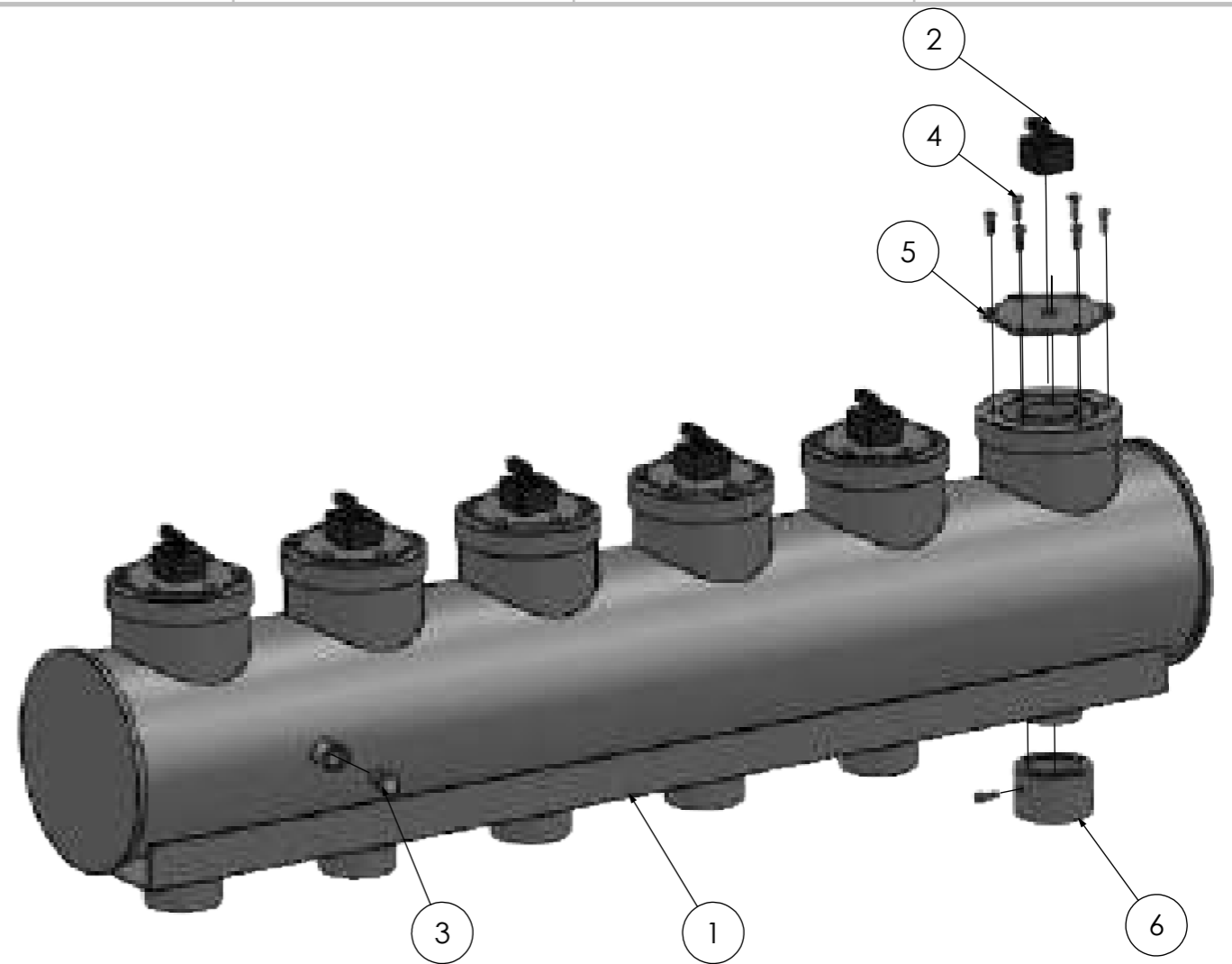

ITEM NO.	PART NUMBER	PART NAME	WEIGHT(KG)	MATERIAL	QTY.
1	BF-01-03-06-01	Bag filter pressurized air tank welded parts	81.0	--	1
2	BF-01-03-06-02	Bag filter pressurized air tank Valve.01 (FP40 TURBO-24VDC-18WATT)	0.1	--	6
3	BF-01-03-06-03	Bolt-Din933-M12x25-8.8	0.0	--	1
4	BF-01-03-06-04	Bolt-Din933-M6x20-8.8	0.0	--	42
5	BF-01-03-06-05	Bag filter pressurized air tank Cap Valve.01	0.5	ST37	6
6	BF-01-03-06-06	Bag filter pressurized air tank bush.01	1.0	ST37	6

ANG.PROJ.:	گروه صنایع سیمان کرمان (سهامی عام)			
<small>ISO 2768-1 (Tolerance Class m)</small> <small>TELORANCE: ISO 2768-2 (Tolerance Class k)</small> <small>ISO 13920 (Tolerance Class A)</small>				
UNIT: mm, kg	NAME	SIGNATURE	DATE	TITLE:
Document Type: Assem	DRAWN: M.H.Izadi			Bag filter pressurized air tank.01
QTY.: ***	CHECKED: M.S.Arabnejad			PART NO.: BF-01-03-06
	APPROVED: A.Anjomshoa			Document ID: **
Revision:				REF. Document ID:
Revision Date:	Material: --			Record ID:
Classification:	WEIGHT: 90.7 Kg	Scale: 1:20	Sheet: 52 of 61	Size: A3

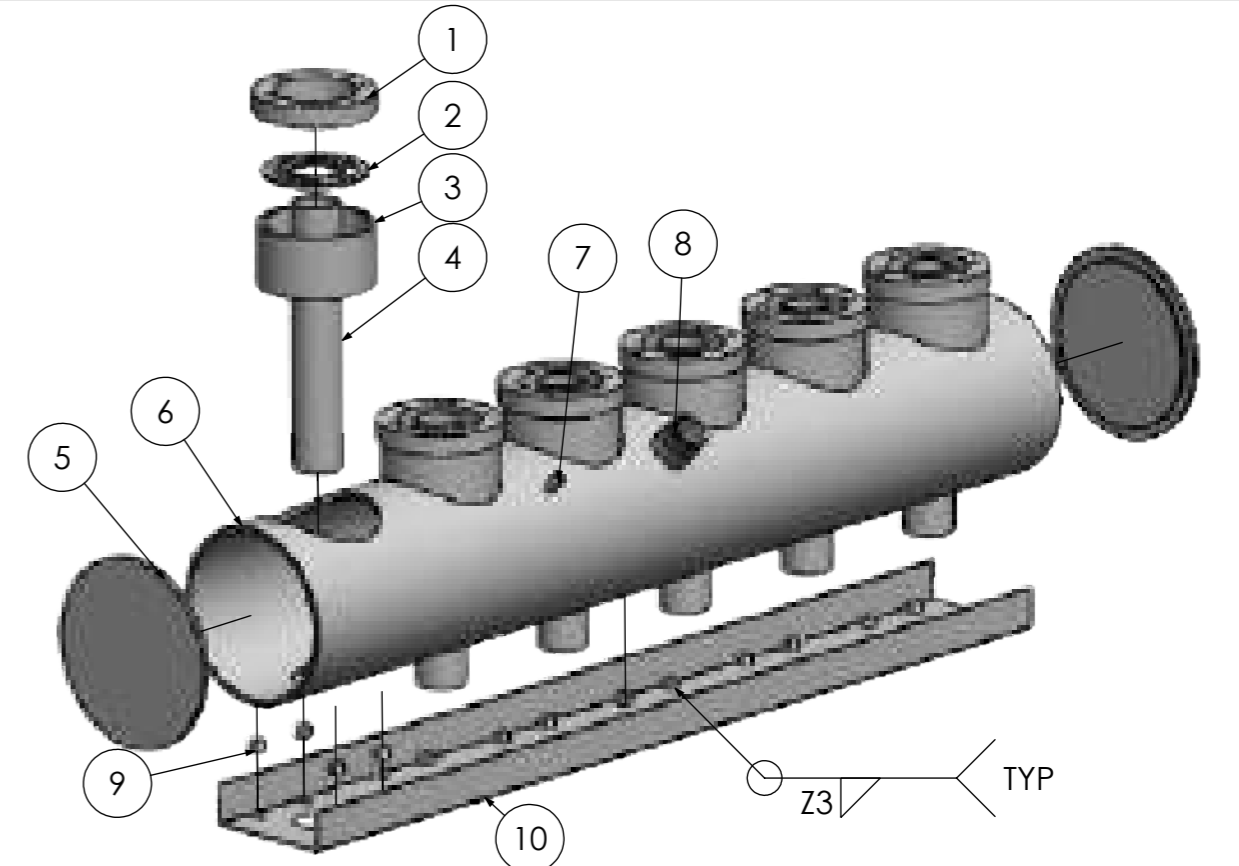
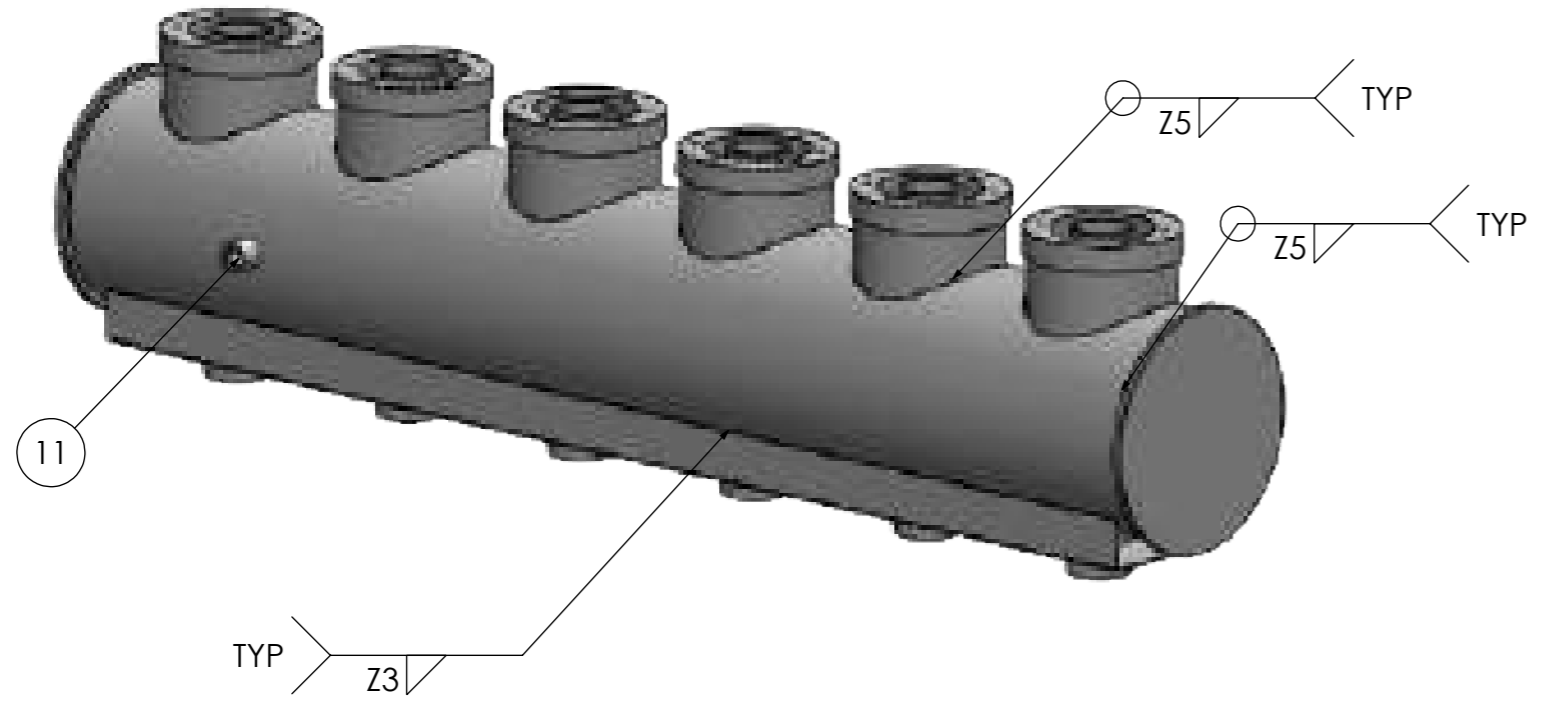
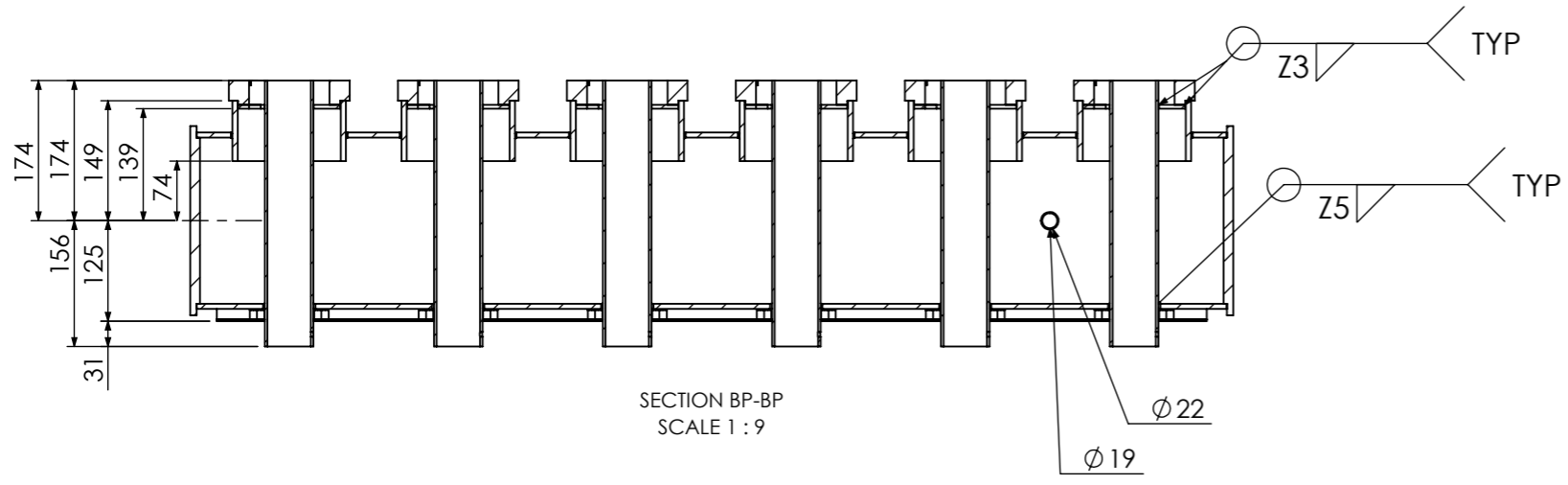
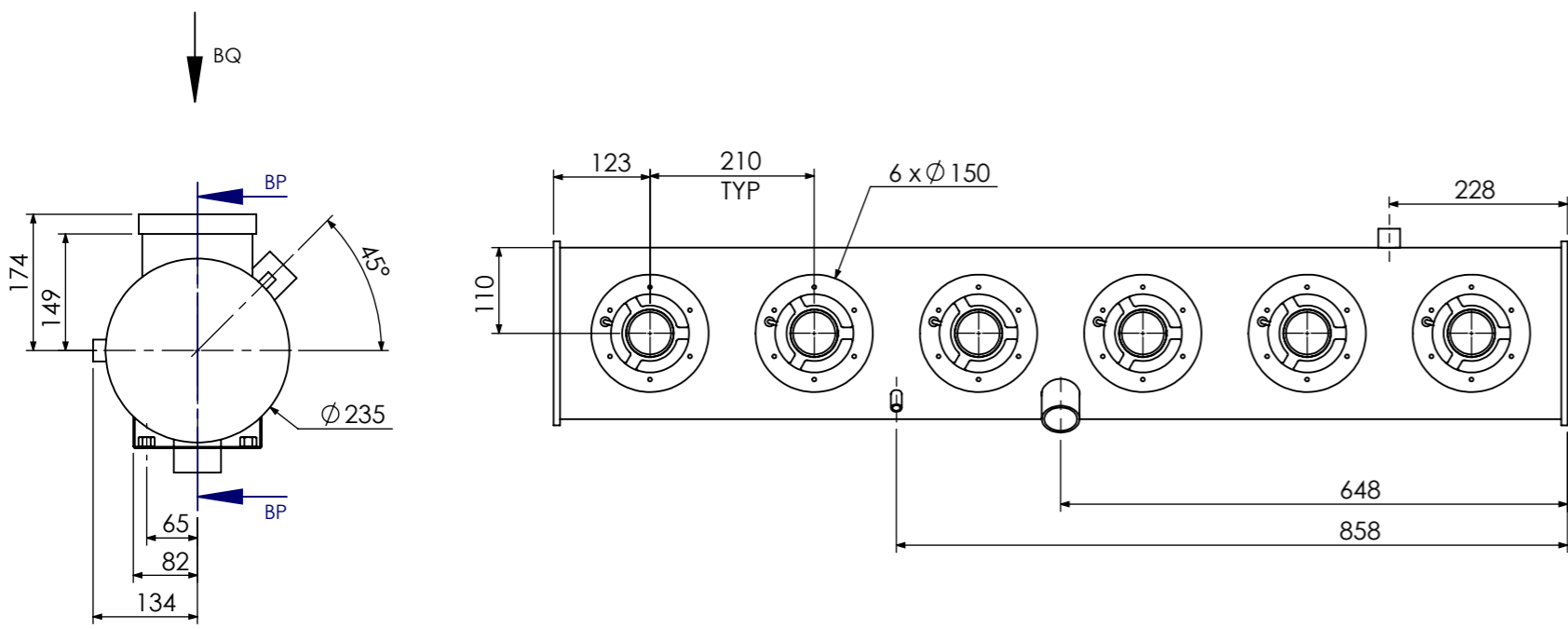

ITEM NO.	PART NUMBER	PART NAME	WEIGHT(KG)	MATERIAL	QTY.
1	BF-01-03-06-01-01	Bag filter pressurized air tank stand valve	2.1	ST37	6
2	BF-01-03-06-01-02	Bag filter pressurized air tank plate.01	0.3	ST37	6
3	BF-01-03-06-01-03	Bag filter pressurized air tank bush.01	1.6	ST37	6
4	BF-01-03-06-01-04	pipe-ANSI B36.19-2inx 3.18mm L=330 mm-welded Pipe	1.5	ST37	6
5	BF-01-03-06-01-05	Bag filter pressurized air tank plate.02	3.7	ST37	2
6	BF-01-03-06-01-06	pipe-ANSI B36.19-8inx 6.35mm-welded Pipe	35.7	ST37	1
7	BF-01-03-06-01-07	pipe-ANSI B36.19-3/8inx 1.85mm-welded Pipe	0.0	ST37	1
8	BF-01-03-06-01-08	pipe-ANSI B36.19-1.1/2inx 3.18mm-welded Pipe	0.2	ST37	1
9	BF-01-03-06-01-09	Nut-Din934-M12	0.0	--	24
10	BF-01-03-06-01-10	Bag filter pressurized air tank plate.03	4.6	ST37	1
11	BF-01-03-06-01-11	Bag filter pressurized air tank bush.02	0.1	ST37	1

ANG.PROJ.:

TELORANCE: ISO 2768-1 (Tolerance Class m) | ISO 2768-2 (Tolerance Class k) | ISO 13920 (Tolerance Class A)

UNIT: mm, kg

Document Type: **Assem**

QTY.: ***

Revision:

Revision Date:

Classification:

WEIGHT: 81.0 Kg

Scale: 1:20

Sheet: 53 of 61

Size: A3

گروه صنایع سیمان کرمان (سهامی عام)

Document Title: **Bag filter pressurized air tank welded parts**

PART NO.: BF-01-03-06-01

Document ID: **

REF. Document ID:

Record ID:

Signature: M.H.Izadi, M.S.Arabnejad, A.Anjomshoa

Date:

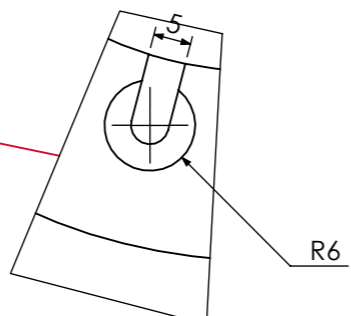
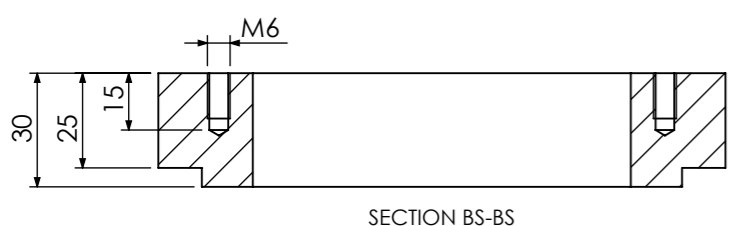
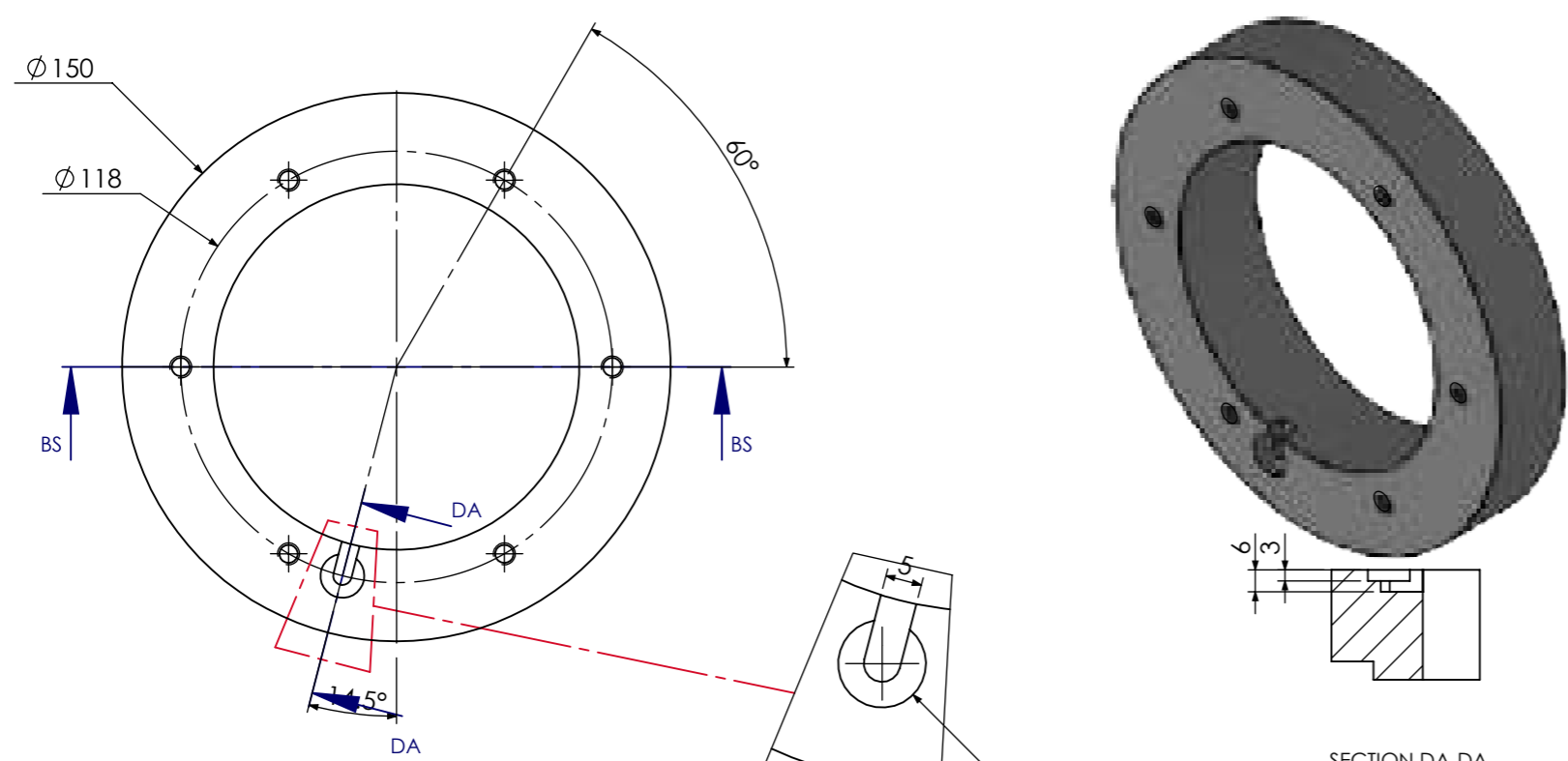

SECTION DA-DA

DETAIL CZ
SCALE 1 : 1

SECTION BS-BS

Bag filter pressurized air
tank stand valve
BF-01-03-06-01-01

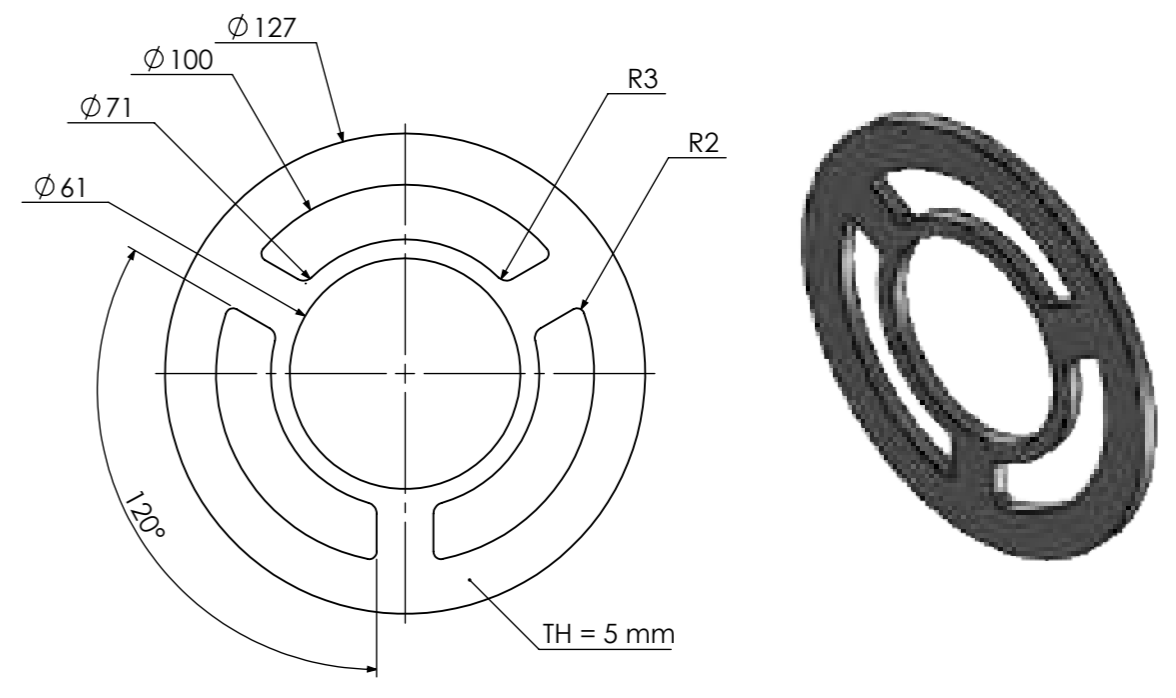

Bag filter pressurized air
tank plate.01
BF-01-03-06-01-02

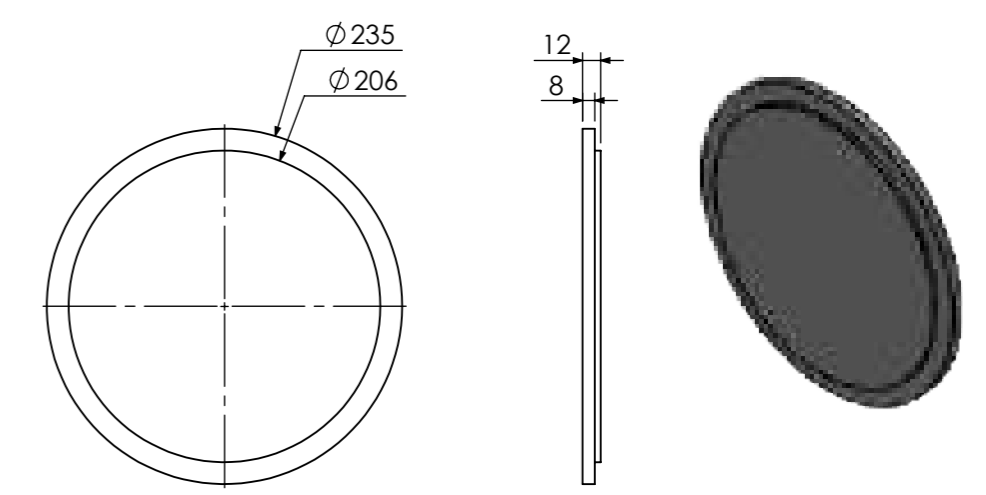

Bag filter pressurized air
tank plate.02
BF-01-03-06-01-05

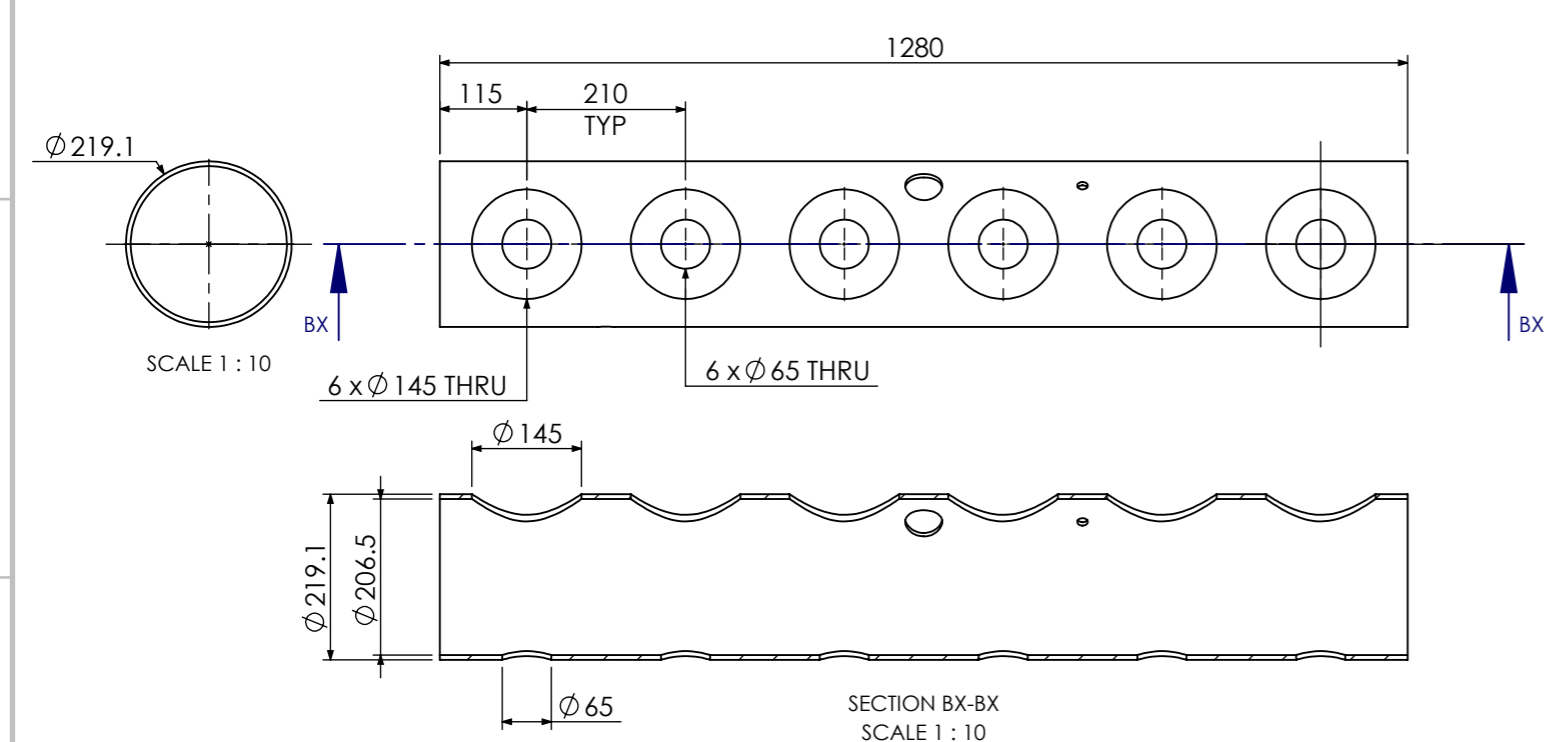

pipe-ANSI B36.19-8inx
6.35mm-welded Pipe
BF-01-03-06-01-06

ANG.PROJ.:					
TELORANCE:	ISO 2768-1 (Tolerance Class m) ISO 2768-2 (Tolerance Class k) ISO 13920 (Tolerance Class A)				گروه صنایع سیمان کرمان (سهامی عام)
UNIT: mm, kg					
Document Type: Assem	NAME	SIGNATURE	DATE	TITLE: Bag filter pressurized air tank stand valve Bag filter pressurized air tank plate(01-02) pipe-ANSI B36.19-8inx 6.35mm-welded Pipe	
	DRAWN	M.H.Izadi		PART NO.: BF-01-03-06-01-(01-02-05-06)	
QTY.: ***	CHECKED	M.S.Arabnejad		Document ID: **	
	APPROVED	A.Anjomshoa		REF. Document ID:	
Revision:				Record ID:	
Revision Date:	Material: --			Scale: 1:2	
Classification:	WEIGHT: 81.0 Kg			Sheet: 54 of 61	
				Size: A3	

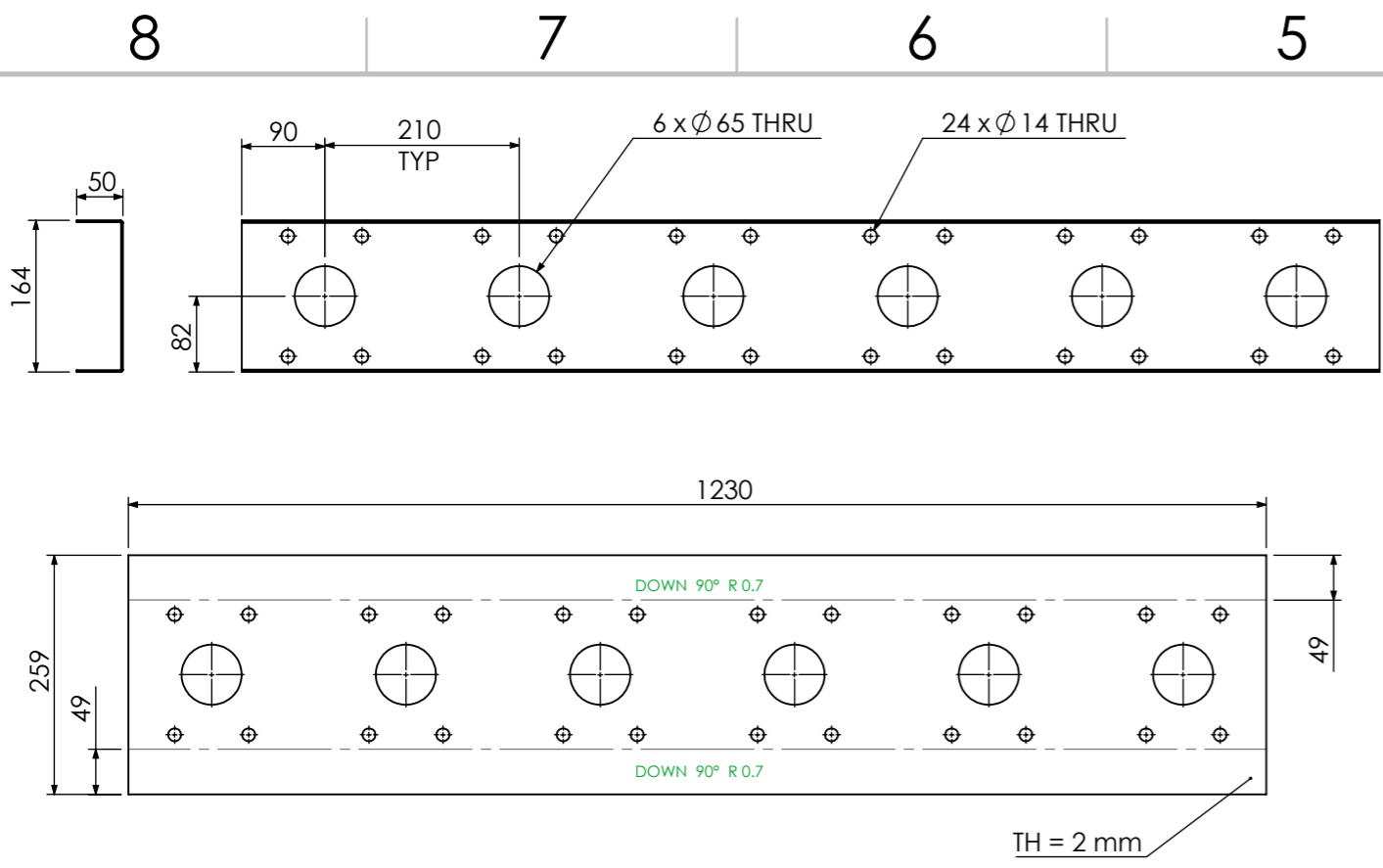

Bag filter pressurized air tank plate.03
BF-01-03-06-01-10

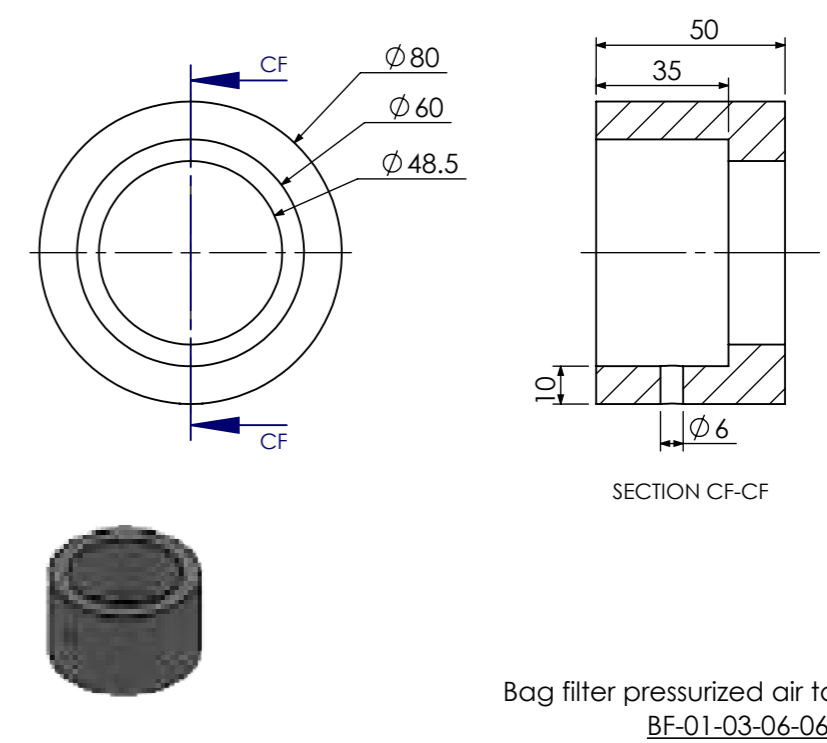

Bag filter pressurized air tank bush.01
BF-01-03-06-06

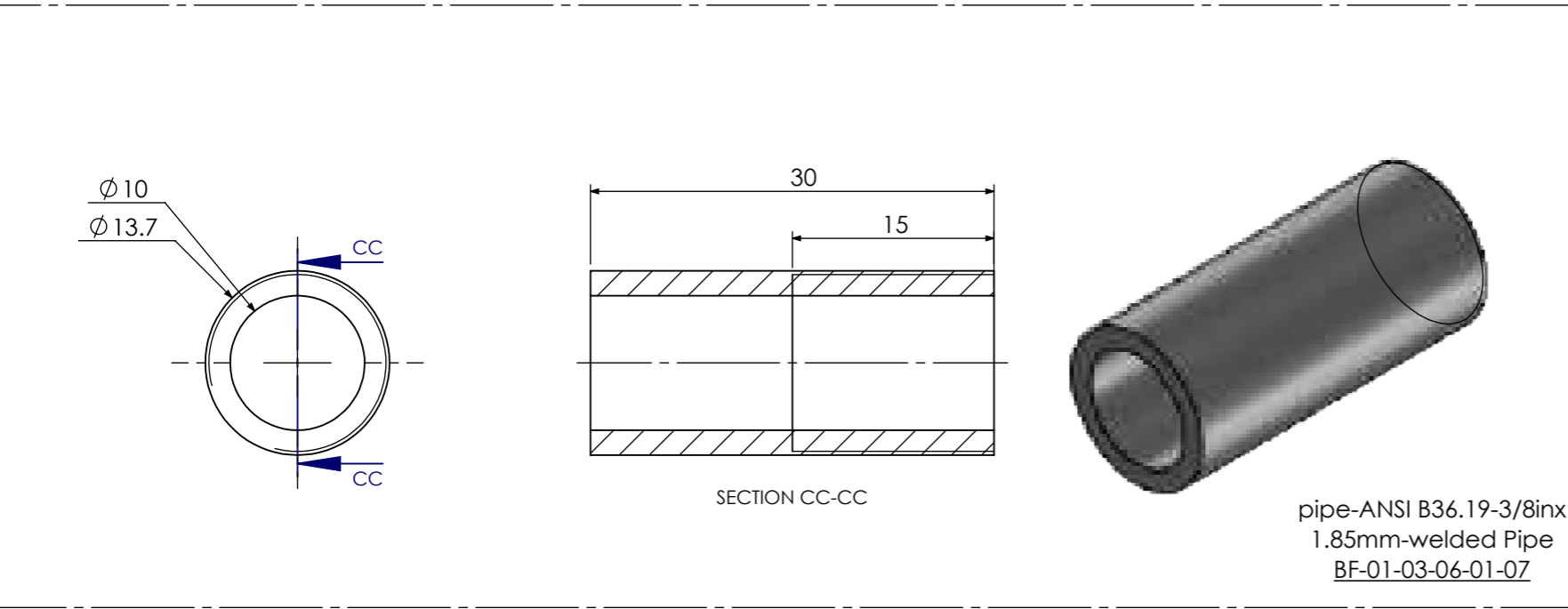

pipe-ANSI B36.19-3/8inx
1.85mm-welded Pipe
BF-01-03-06-01-07

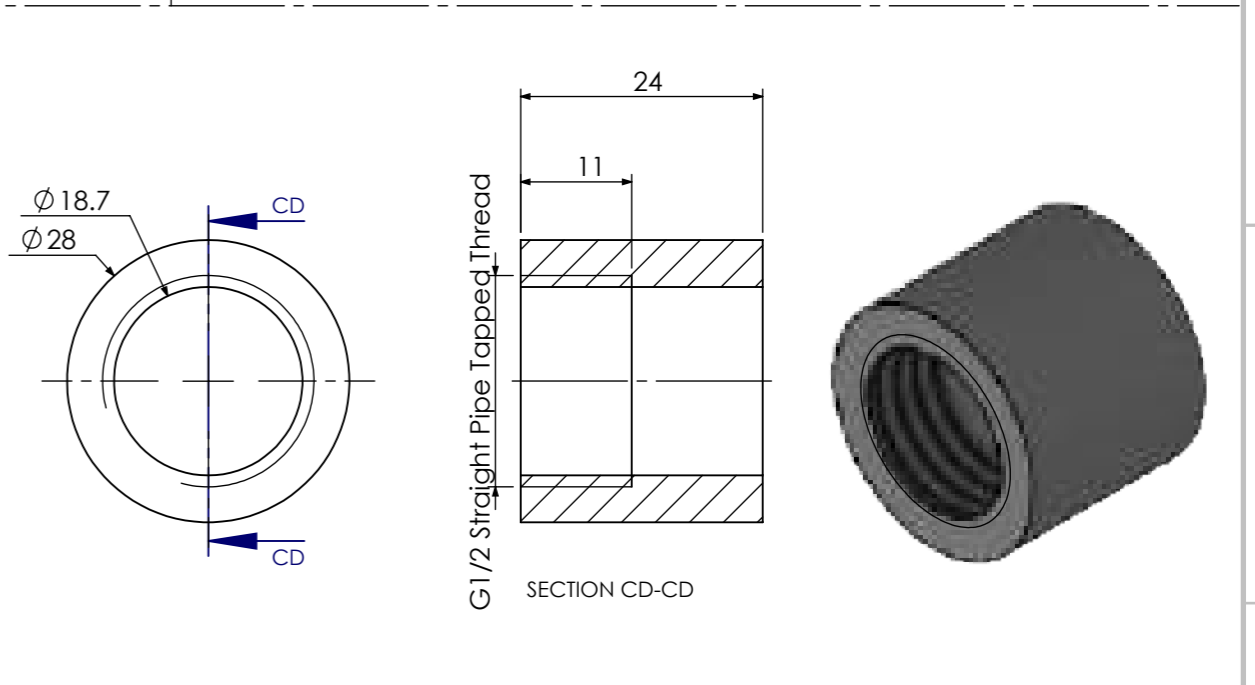

Bag filter pressurized air tank bush.02
BF-01-03-06-01-11

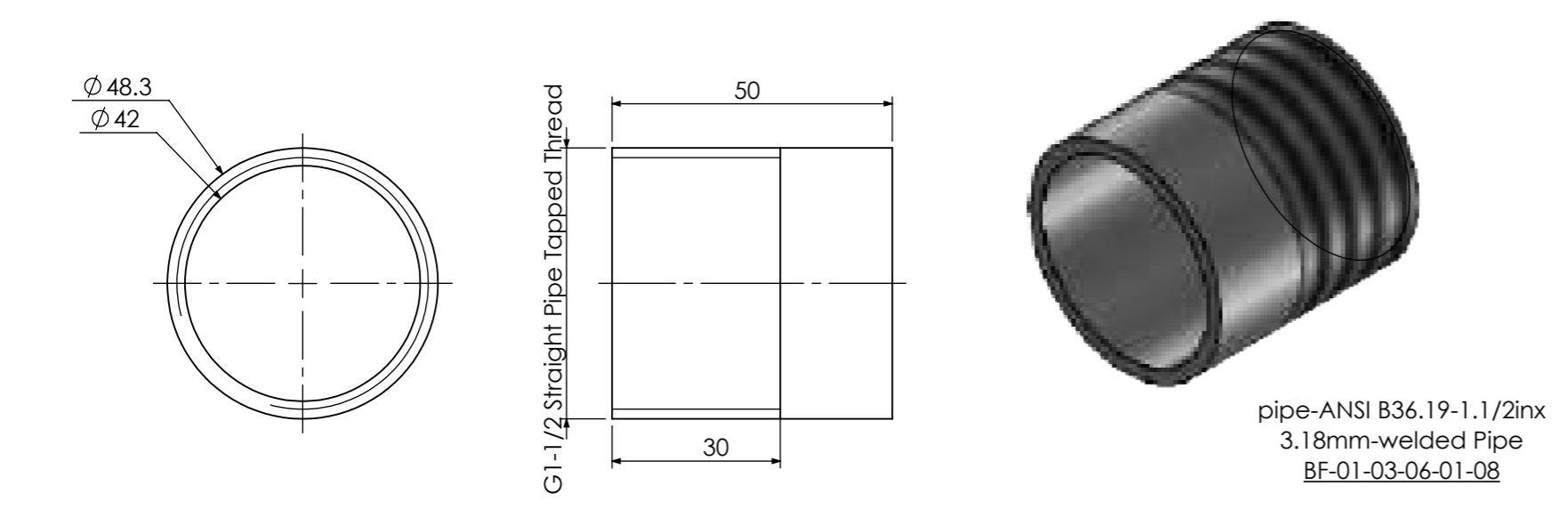

pipe-ANSI B36.19-1.1/2inx
3.18mm-welded Pipe
BF-01-03-06-01-08

ANG.PROJ.:	گروه صنایع سیمان کرمان (سهامی عام)			
TOLERANCE: ISO 2768-1 (Tolerance Class m) ISO 2768-2 (Tolerance Class k) ISO 13920 (Tolerance Class A)				
UNIT: mm, kg				
Document Type: Part	NAME	SIGNATURE	DATE	TITLE: Bag filter pressurized air tank plate.03 Bag filter pressurized air tank bush.02 pipe-ANSI B36.19-1.1/2inx 3.18mm-welded Pipe ppppp
QTY: ***	DRAWN	M.H.Izadi		PART NO.: BF-01-03-06-01-(07-08-10-11)
	CHECKED	M.S.Arabnejad		
	APPROVED	A.Anjomshoa		REF. Document ID:
Revision:				Record ID:
Revision Date:	Material: --			Scale: 1:10
Classification:	WEIGHT: 81.0 Kg	Sheet: 55 of 61		Size: A3

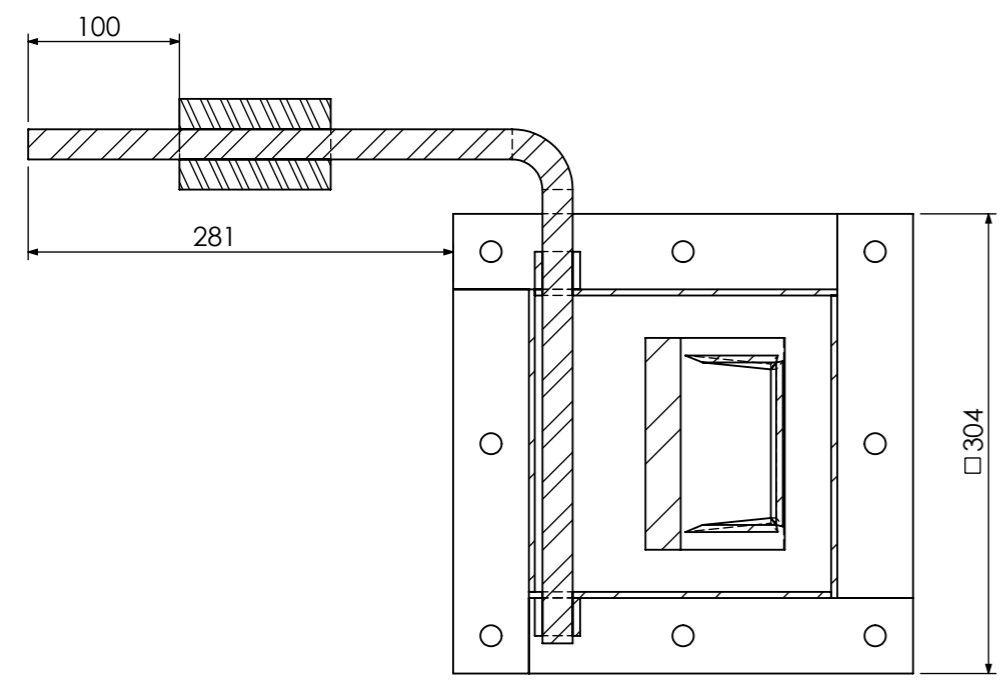
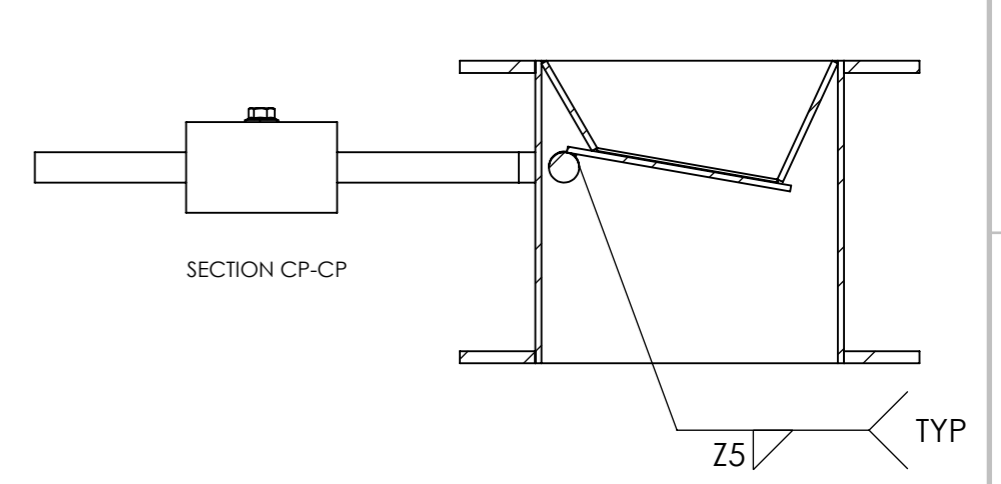
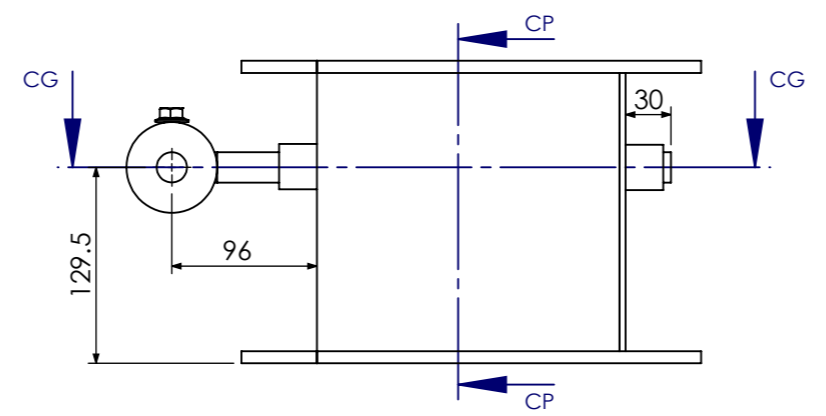
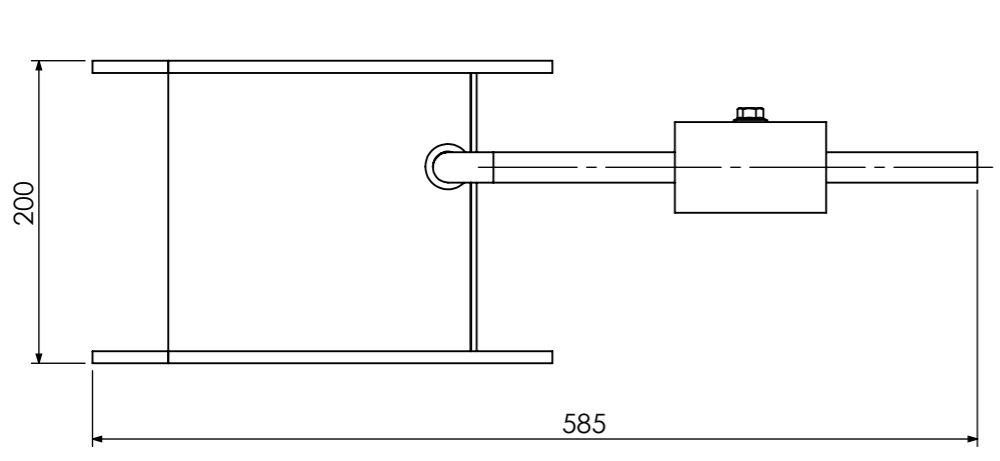

SECTION CG-CG

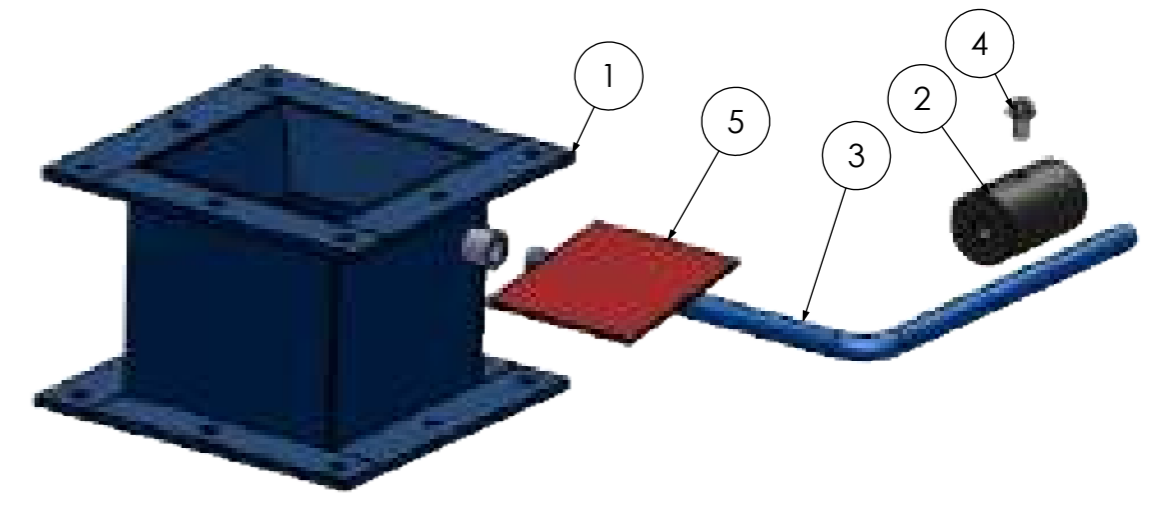

ITEM NO.	PART NUMBER	PART NAME	WEIGHT(KG)	MATERIAL	QTY.
1	BF-01-04-01	Bag filter air lock welded parts	12.9	--	1
2	BF-01-04-02	Bag filter air lock weight bush.01	2.0	ST37	1
3	BF-01-04-03	Bag filter air lock L rod	1.6	ST37	1
4	BF-01-04-04	Bolt-Din933-M10x20-8.8	0.0	--	1
5	BF-01-04-05	Bag filter air lock plate.01 (150 mm x 140 mm x 4 mm)	0.7	ST37	1

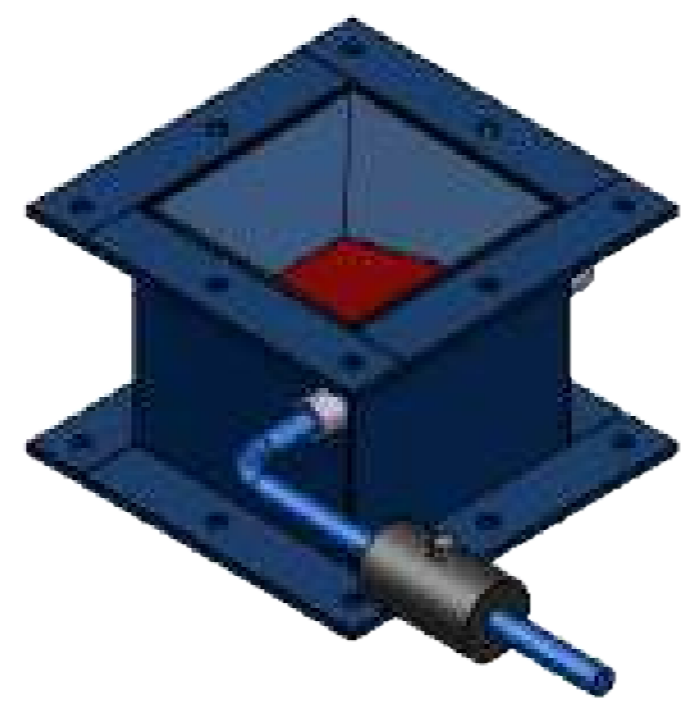

ANG.PROJ.:

ISO 2768-1 (Tolerance Class m)
 ISO 2768-2 (Tolerance Class k)
 ISO 13920 (Tolerance Class A)

UNIT: mm, kg

Document Type: **Assem**

QTY.: ***

Revision:

Revision Date:

Classification:

گروه صنایع سیمان کرمان
 (سهامی عام)

کارخانه سیمان کرمان

تابلو صنایع سیمان کرمان

TITLE: **Bag filter air lock**

PART NO.: BF-01-04-00

Document ID: **

REF. Document ID:

Record ID:

WEIGHT: 17.1 Kg

Scale: 1:5

Sheet: 56 of 61

Size: A3

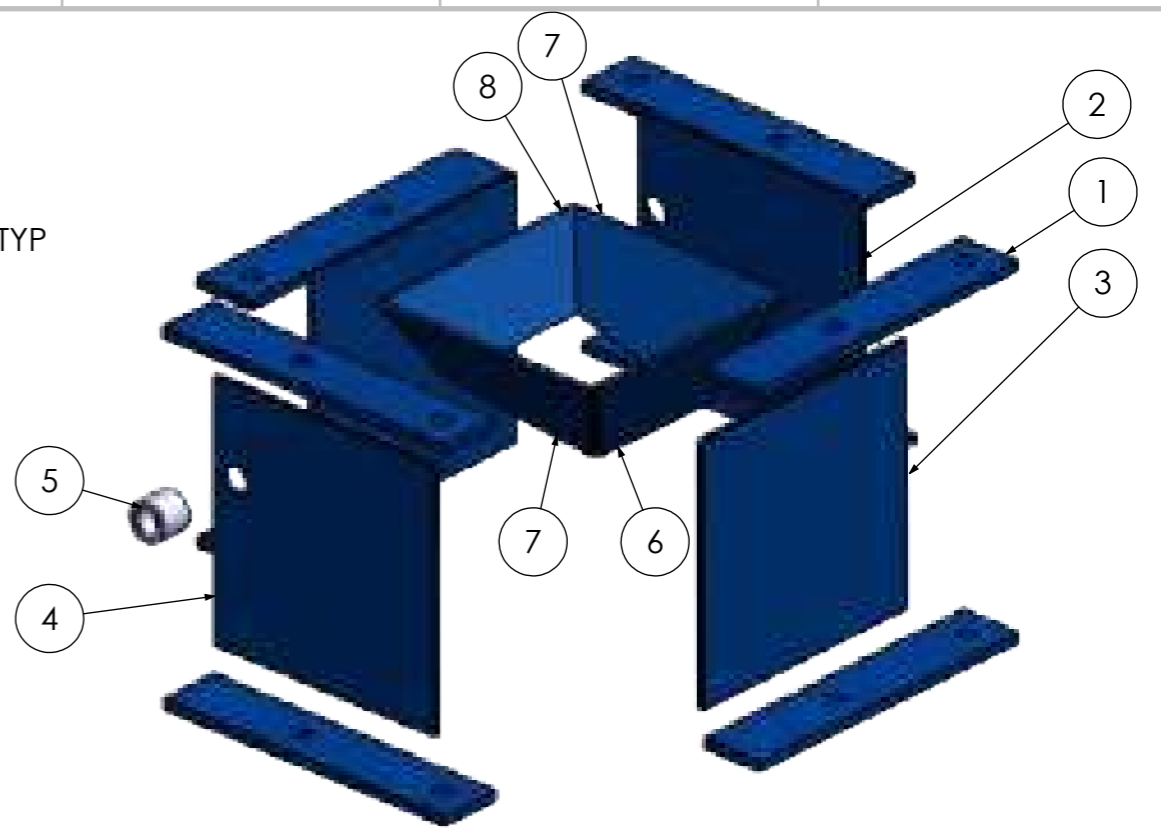
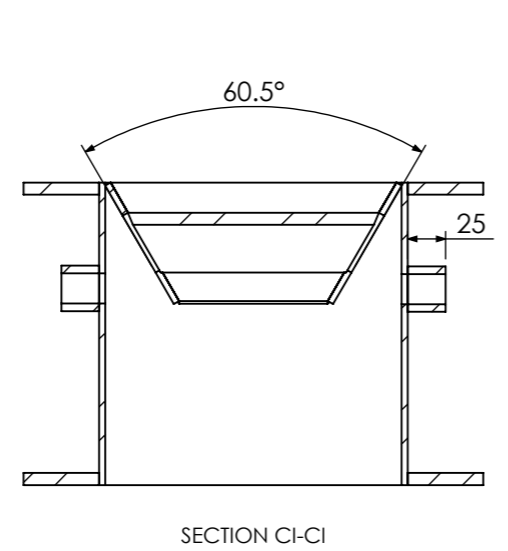
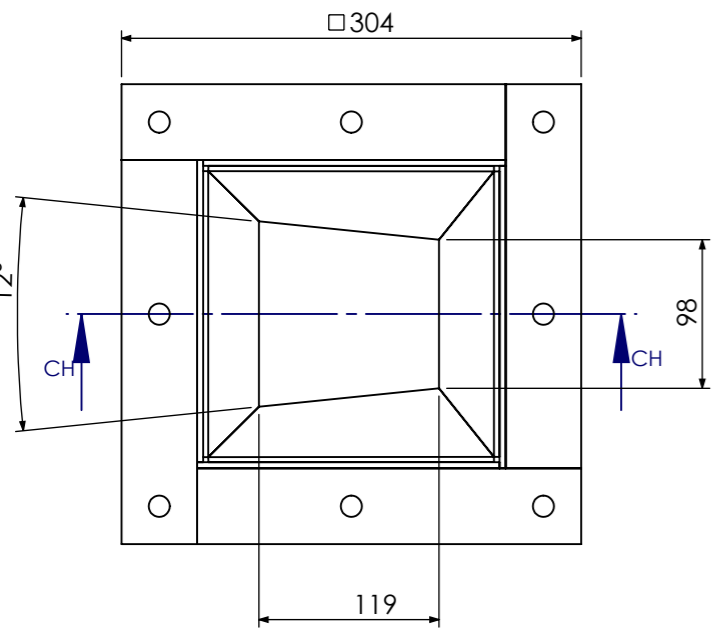
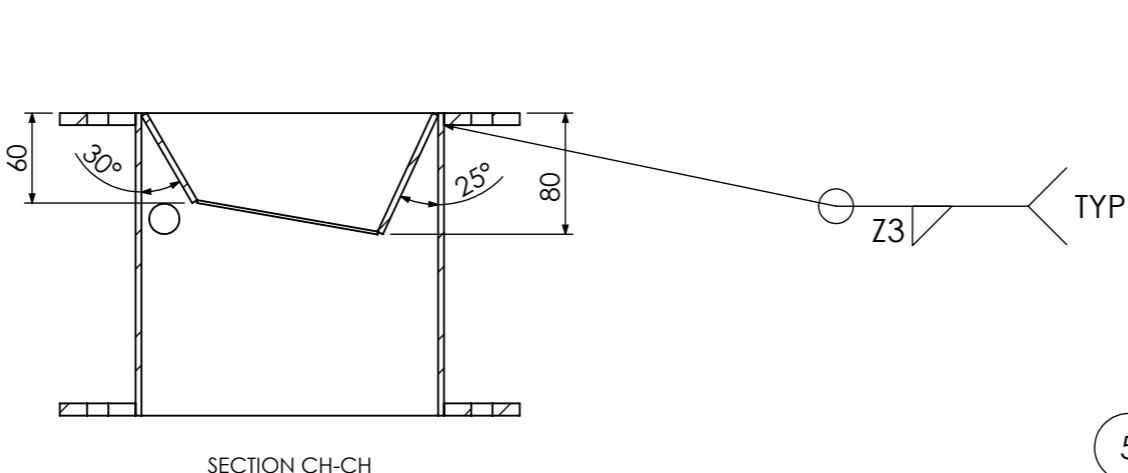
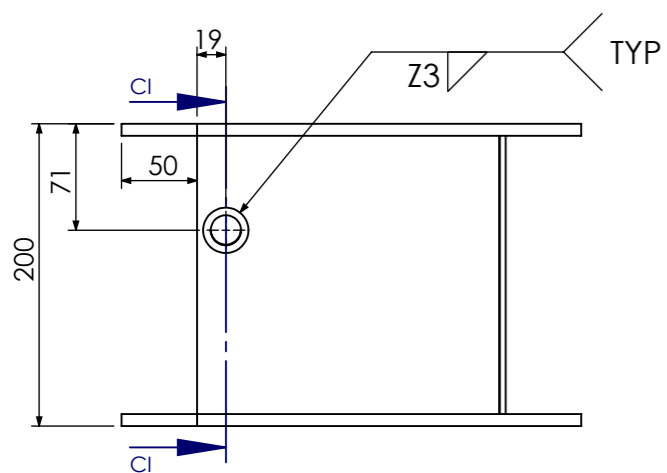

ITEM NO.	PART NUMBER	PART NAME	WEIGHT(KG)	MATERIAL	QTY.
1	BF-01-02-10	Bag filter dust hopper plate.05	0.8	ST37	8
2	BF-01-04-01-01	Bag filter air lock welded plate.02	1.2	ST37	1
3	BF-01-04-01-02	Bag filter air lock welded plate.03 (200 mm x 2000 mm x 4 mm)	1.3	ST37	2
4	BF-01-04-01-03	Bag filter air lock welded plate.04	1.2	ST37	1
5	BF-01-04-01-04	Bag filter air lock welded bush.02	0.1	ST37	2
6	BF-01-04-01-05	Bag filter air lock welded plate.05	0.4	ST37	1
7	BF-01-04-01-06	Bag filter air lock welded plate.06	0.4	ST37	2
8	BF-01-04-01-07	Bag filter air lock welded plate.07	0.3	ST37	1

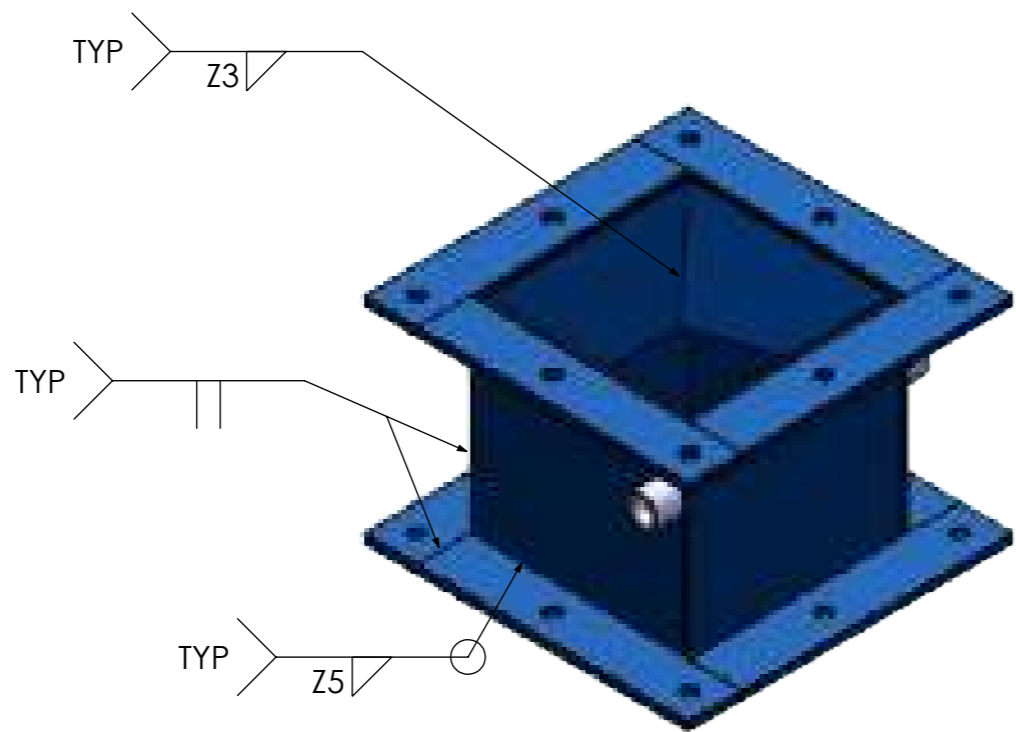

ANG.PROJ.:

TELORANCE: ISO 2768-1 (Tolerance Class m) ISO 2768-2 (Tolerance Class k) ISO 13920 (Tolerance Class A)

UNIT: mm, kg

Document Type: **Assem**

QTY.: ***

Revision:

Revision Date:

Classification:

WEIGHT: 12.9 Kg

Scale: 1:5

Sheet: 57 of 61

Size: A3

گروه صنایع سیمان کرمان (سهامی عام)

کارخانه سیمان کرمان

سپهر صنعتی سیمان کرمان

NAME: M.H.Izadi

SIGNATURE: M.S.Arabnejad

DATE: A.Anjomshoa

TITLE: **Bag filter air lock welded parts**

PART NO.: BF-01-04-01

Document ID: **

REF. Document ID:

Record ID:

8 7 6 5 4 3 2 1

F

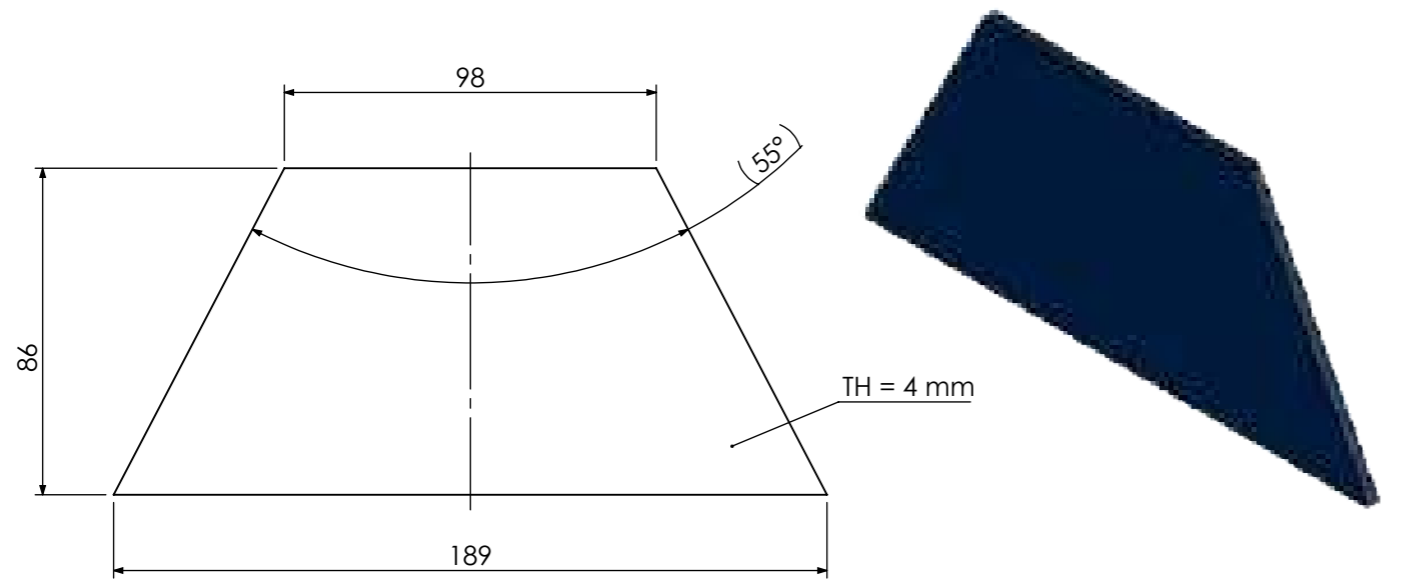

Bag filter air lock welded plate.05
BF-01-04-01-05

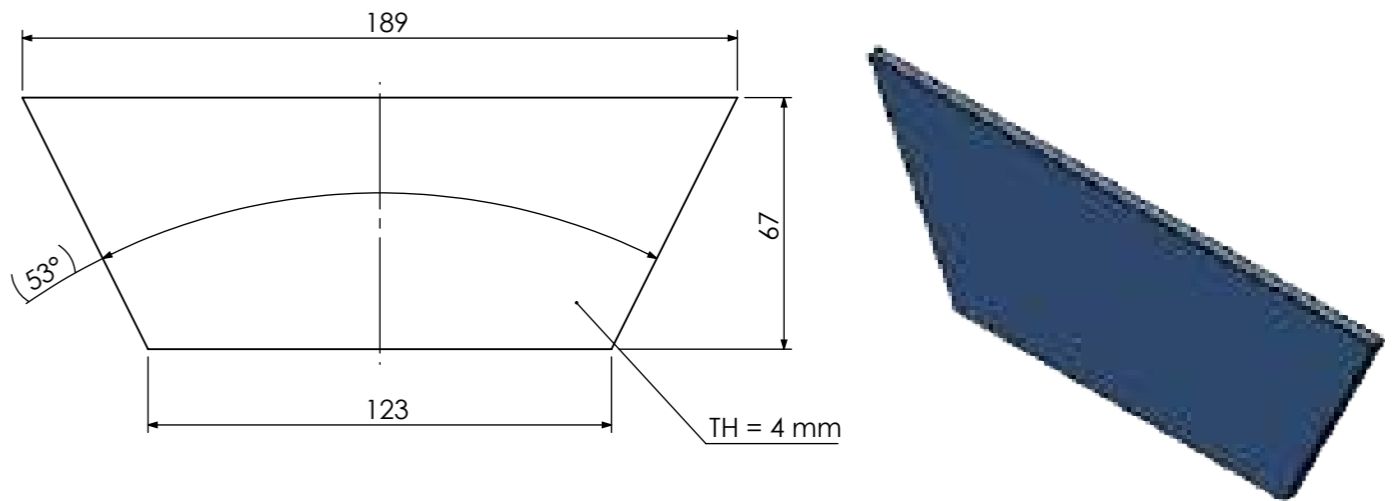

Bag filter air lock welded plate.07
BF-01-04-01-07

D

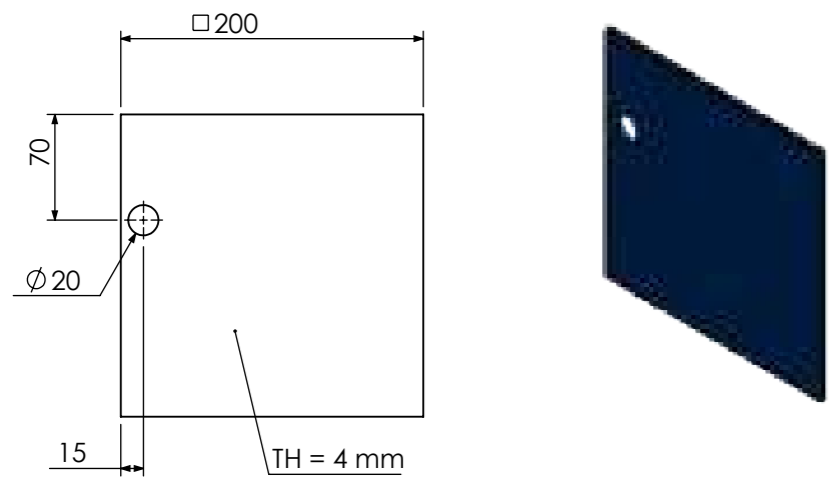

Bag filter air lock welded plate.04
BF-01-04-01-03

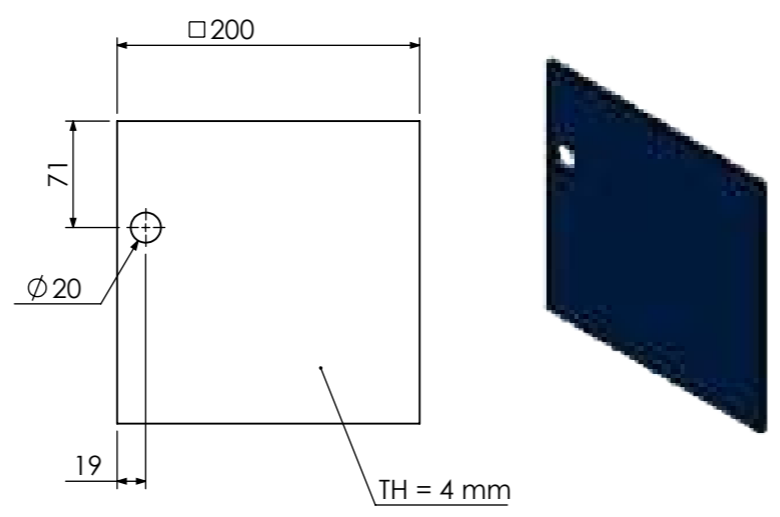

Bag filter air lock welded plate.02
BF-01-04-01-01

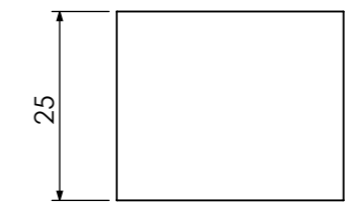
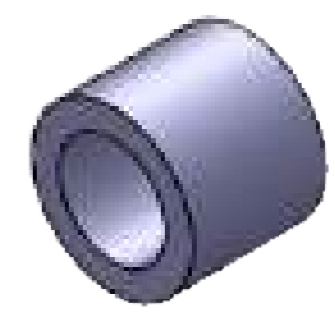
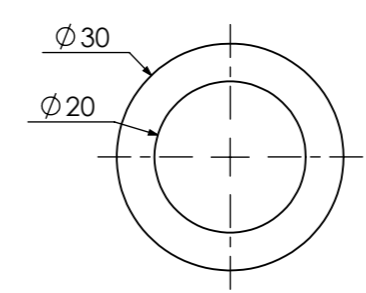

Bag filter air lock welded bush.02
BF-01-04-01-04

B

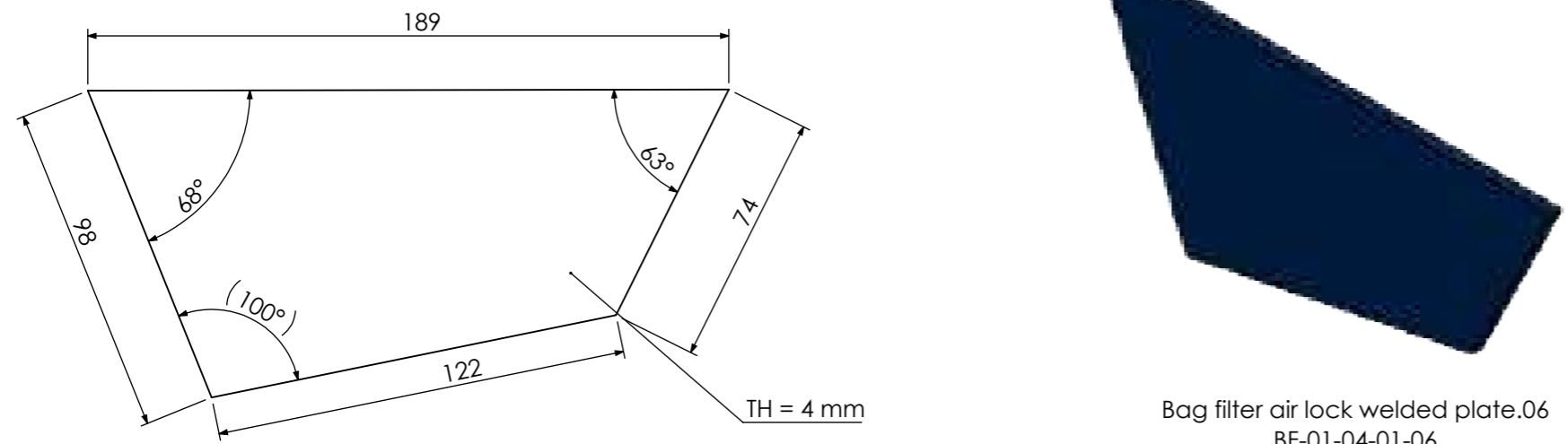

Bag filter air lock welded plate.06
BF-01-04-01-06

ANG.PROJ.:	گروه صنایع سیمان کرمان (سهامی عام)			
<small>ISO 2768-1 (Tolerance Class m)</small> <small>ISO 2768-2 (Tolerance Class k)</small> <small>ISO 13920 (Tolerance Class A)</small>				
UNIT: mm, kg				
Document Type: Part	NAME	SIGNATURE	DATE	TITLE:
	DRAWN	M.H.Izadi		Bag filter air lock welded plate(02-04-05_06-07) Bag filter air lock welded bush.02
QTY.: ***	CHECKED	M.S.Arabnejad		PART NO.: BF-01-04-01-(01-03-04-05-06-07)
	APPROVED	A.Anjomshoa		Document ID: **
Revision:				REF. Document ID:
Revision Date:	Material: --			Record ID:
Classification:	WEIGHT: 1.2 Kg	Scale: 1:2	Sheet: 58 of 61	Size: A3

8 7 6 5 4 3 2 1

A

A

8 7 6 5 4 3 2 1

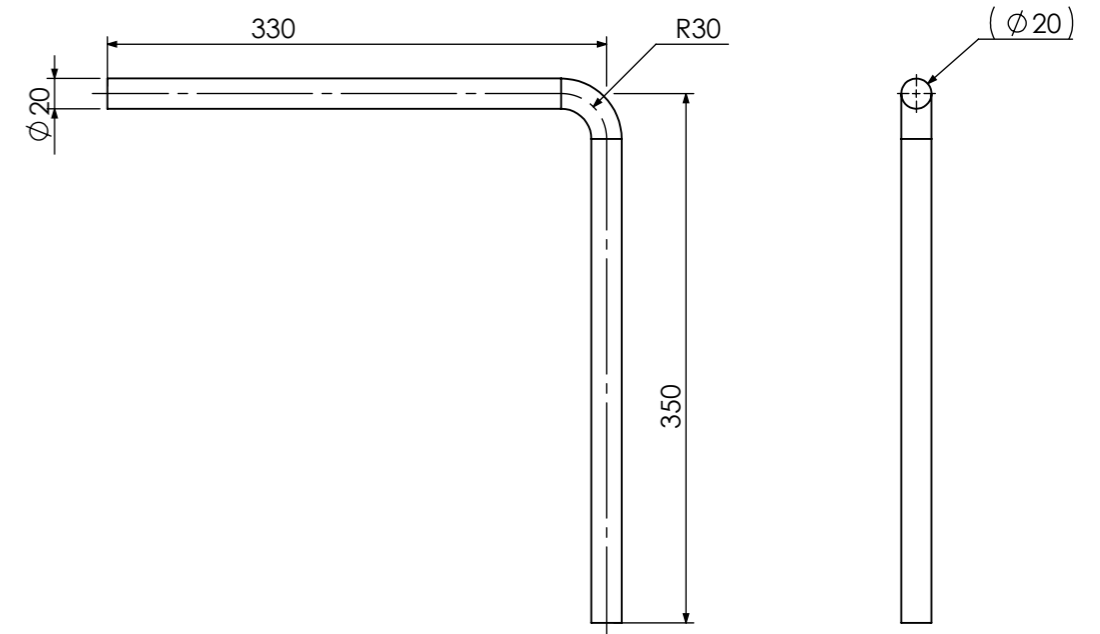
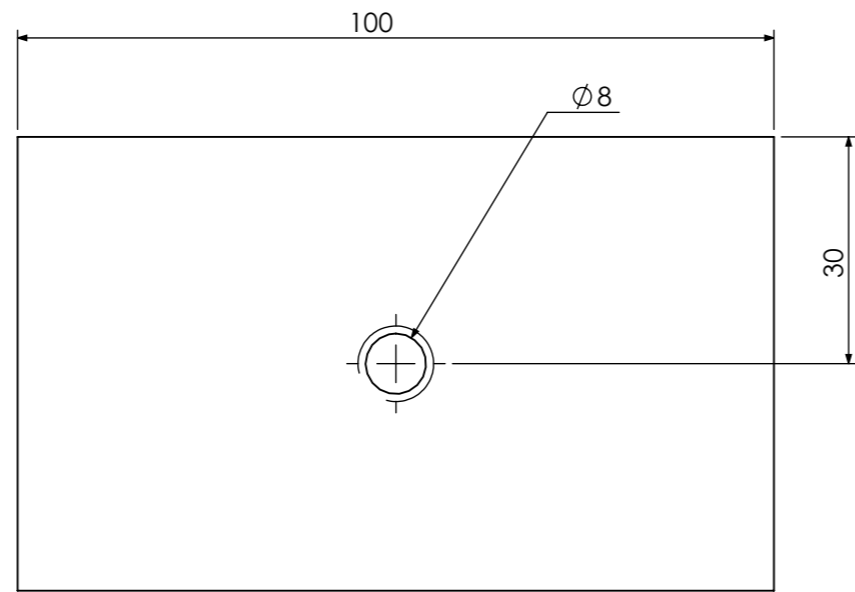
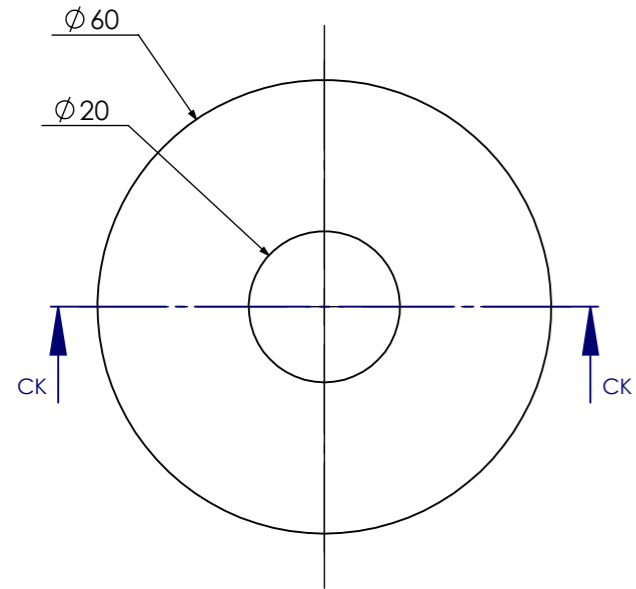

Bag filter air lock L rod
BF-01-04-03

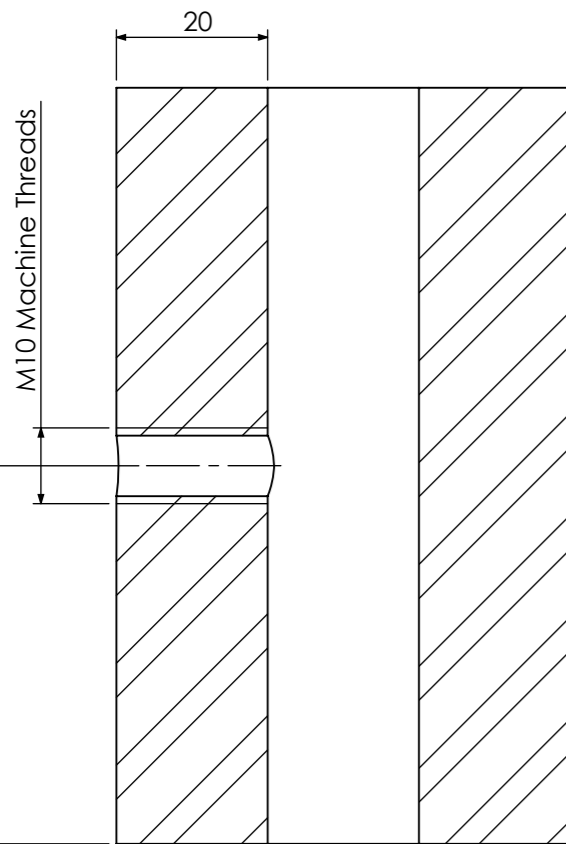

SECTION CK-CK



Bag filter air lock weight bush.01
BF-01-04-02

ANG.PROJ.:				گروه صنایع سیمان کرمان (سهامی عام)	
TELORANCE: ISO 2768-1 (Tolerance Class m) ISO 2768-2 (Tolerance Class k) ISO 13920 (Tolerance Class A)					
UNIT: mm, kg					
Document Type: Part	NAME	SIGNATURE	DATE	TITLE: Bag filter air lock weight bush.01 Bag filter air lock L rod	
QTY.: ***	DRAWN: M.H.Izadi			PART NO.: BF-01-04-(02-03)	
	CHECKED: M.S.Arabnejad			Document ID: **	
	APPROVED: A.Anjomshoa				
Revision:				REF. Document ID:	
Revision Date:	Material: --			Record ID:	
Classification:	WEIGHT: 2.0 Kg	Scale: 1:1		Sheet: 59 of 61	Size: A3

8 7 6 5 4 3 2 1

F
E
D
C
B
A

F
E
D
C
B
A

8 7 6 5 4 3 2 1

F

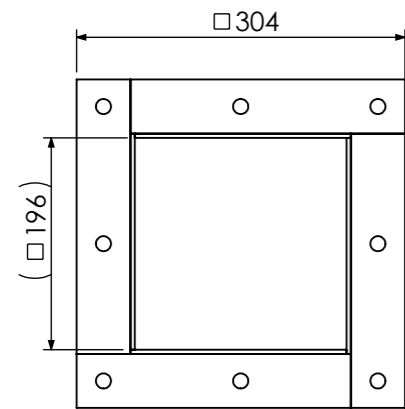

SCALE 1 : 7

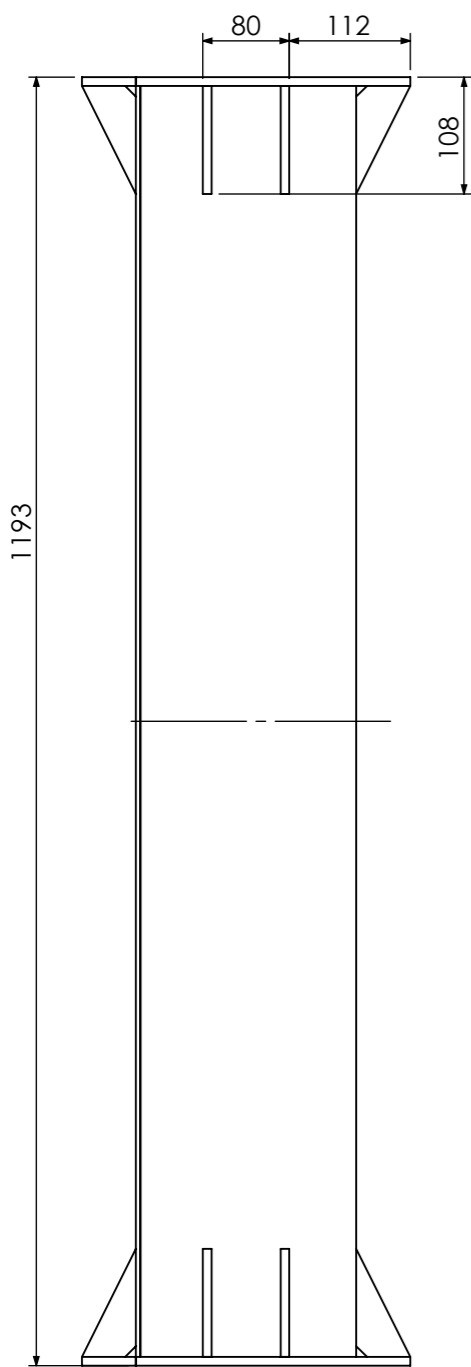

SCALE 1 : 7

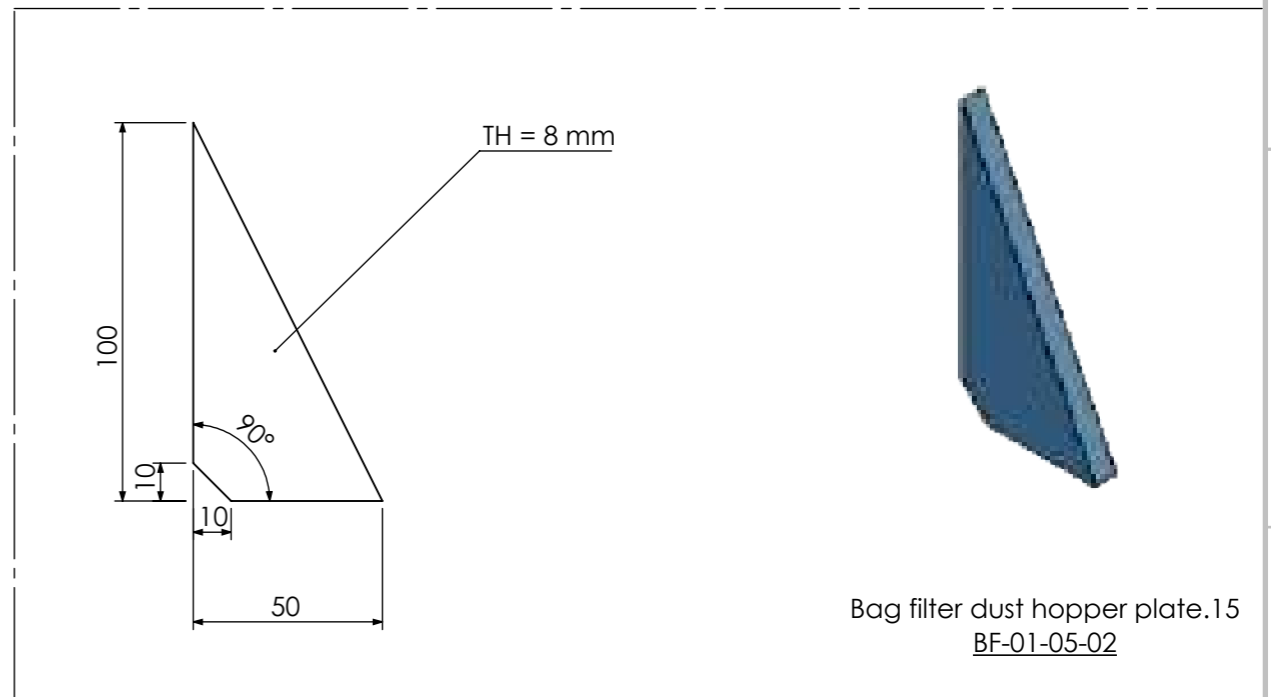
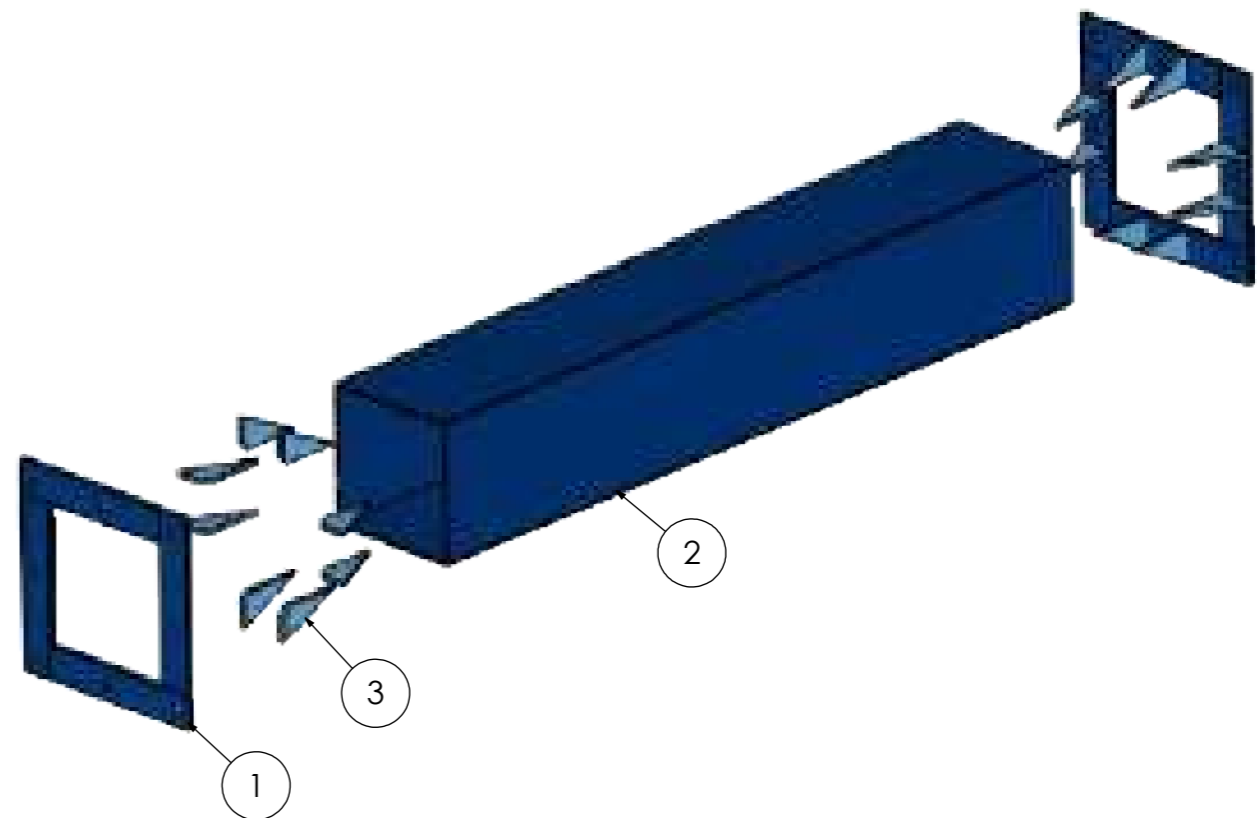
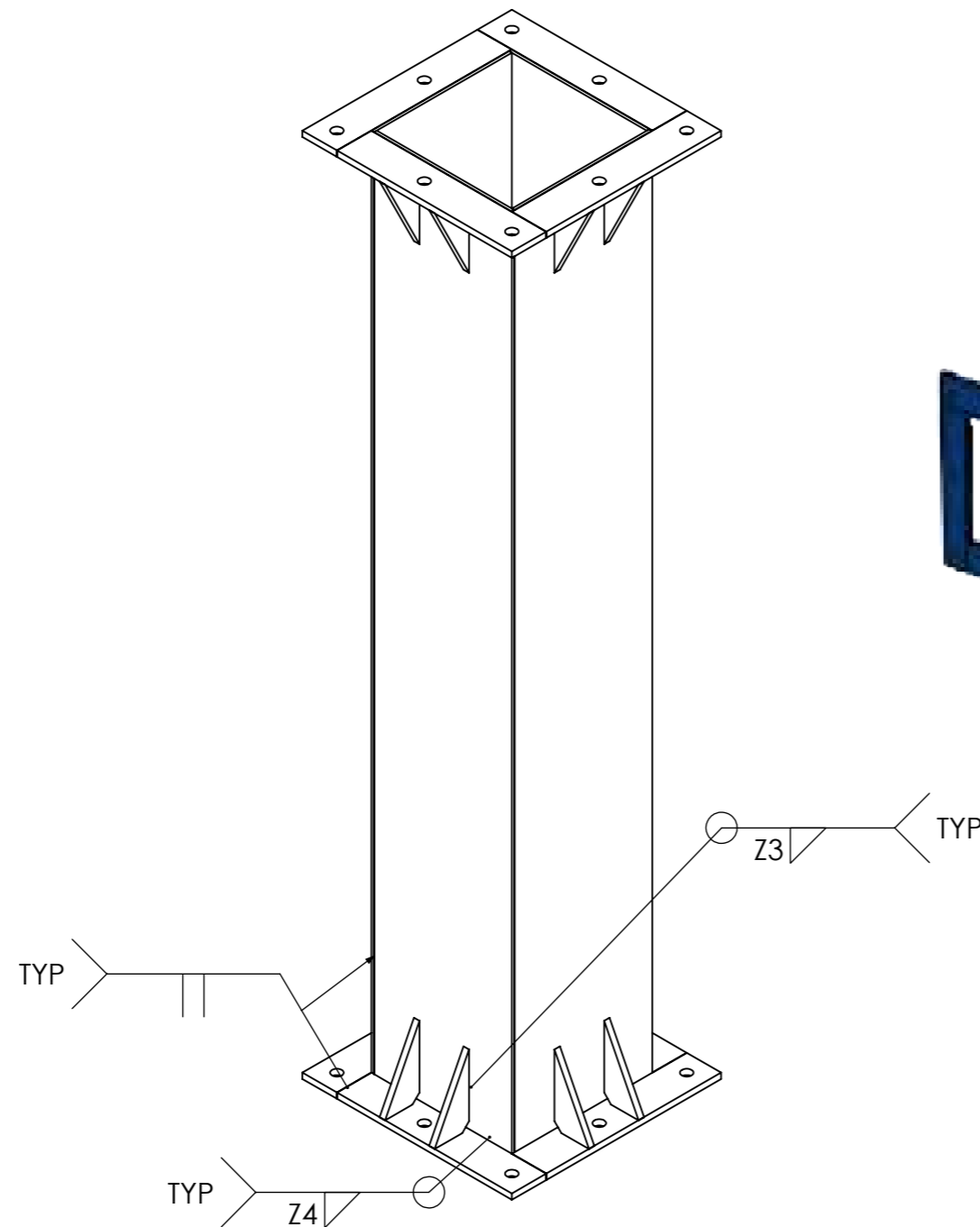

ANG.PROJ.:				گروه صنایع سیمان کرمان		
TELORANCE: ISO 2768-1 (Tolerance Class m) ISO 2768-2 (Tolerance Class k) ISO 13920 (Tolerance Class A)						
UNIT: mm, kg						(سهامی عام)
Document Type: Assem	NAME	SIGNATURE	DATE	TITLE: Bag filter chute		
	DRAWN	M.H.Izadi		PART NO.: BF-01-05-00		
QTY.: ***	CHECKED	M.S.Arabnejad		Document ID: **		
	APPROVED	A.Anjomshoa		REF. Document ID:		
Revision:				Record ID:		
Revision Date:	Material: --			Scale: 1:10		
Classification:	WEIGHT: 38.6 Kg			Sheet: 60 of 61		Size: A3

ITEM NO.	PART NUMBER	PART NAME	WEIGHT(KG)	MATERIAL	QTY.
1	BF-01-02-10	Bag filter dust hopper plate.05	0.8	ST37	8
2	BF-01-05-01	Bag filter dust hopper plate.14 (1192.5 mm x 200 mm x 4 mm)	7.5	ST37	4
3	BF-01-05-02	Bag filter dust hopper plate.15	0.2	ST37	16

8 7 6 5 4 3 2 1

F

E

D

C

B

A

8 7 6 5 4 3 2 1

F

F

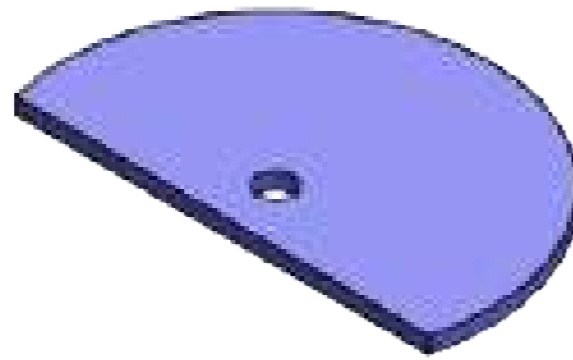
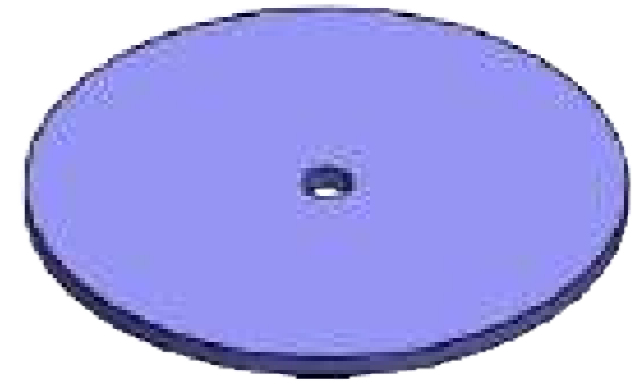
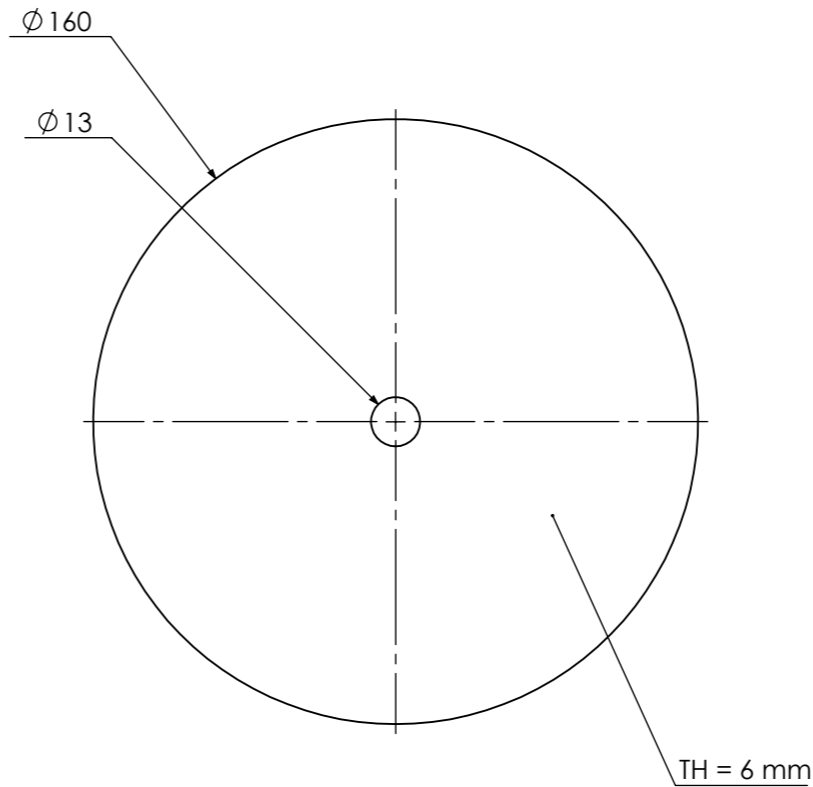
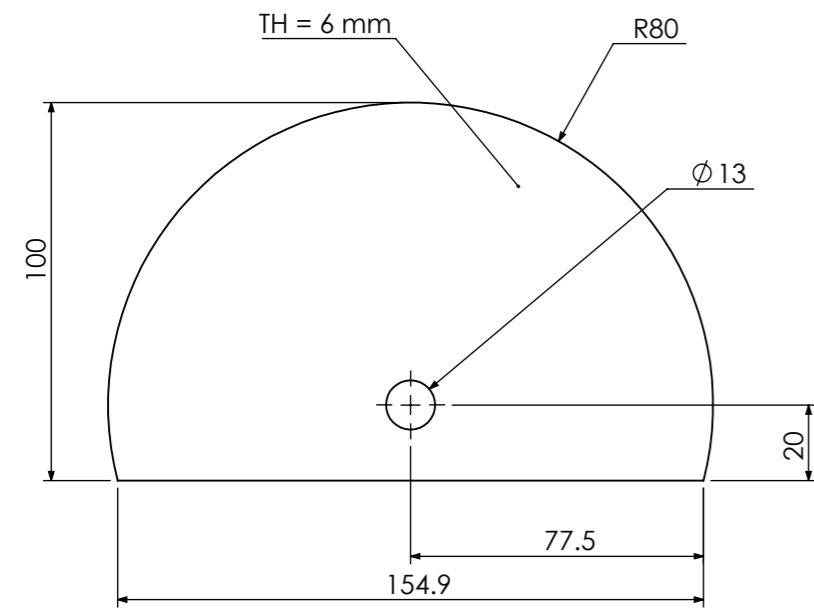

Bag filter bags holder plate 02
BF-01-10-00

Bag filter bags holder plate 01
BF-01-09-00

ANG.PROJ.:				گروه صنایع سیمان کرمان (سهامی عام)		
ISO 2768-1 (Tolerance Class m) ISO 2768-2 (Tolerance Class k) ISO 13920 (Tolerance Class A)						
UNIT: mm, kg						
Document Type: Part	NAME	SIGNATURE	DATE	TITLE: Bag filter bags holder plate 01 Bag filter bags holder plate (01-02)		
QTY.: ***	CHECKED	M.S.Arabnejad		PART NO.: BF-01-09-00 BF-01-10-00		
	APPROVED	A.Anjomshoa		Document ID: **		
Revision:					REF. Document ID:	
Revision Date:	Material: --				Record ID:	
Classification:	WEIGHT: 0.94 Kg	Scale: 1:1		Sheet: 61 of 61	Size: A3	

8 7 6 5 4 3 2 1

A

A